

**'C' Series
Control Valves**
Installation and Maintenance Instructions

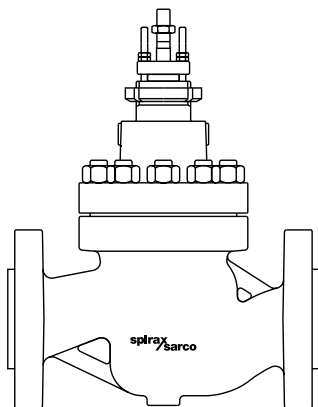

- 1. Safety information*
- 2. General product information*
- 3. Installation and Commissioning*
- 4. Maintenance*
- 5. Spare parts*

1. Safety information

1.1 General

Safe operation of the unit can only be guaranteed if it is properly installed, commissioned and maintained by a qualified person in compliance with the operating instructions. General installation and safety instructions for pipeline and plant construction, as well as the proper use of tools and safety equipment must also be complied with.

1.2 Isolation

Consider whether closing isolating valves will put any other part of the system or personnel at risk. Dangers might include; isolation of vents, protective devices or alarms. Ensure isolation valves are turned on and off in a gradual way to avoid system shocks.

1.3 Pressure

Before attempting any maintenance of the valve consider what is or may have been in the pipeline. Ensure that any pressure is isolated and safely vented, before attempting to maintain the valve. Do not assume that the system or valve is depressurised even when a pressure gauge indicates zero.

1.4 Temperature

Allow time for the temperature to normalise after isolation to avoid the danger of burns and consider whether protective clothing (including safety glasses) is required.

1.5 Handling precautions

PTFE:-

Within its working temperature range PTFE is a completely inert material, but when heated to its sintering temperature it gives rise to gaseous decomposition products or fumes which can produce unpleasant effects if inhaled. The inhalation of these fumes is easily prevented by applying local exhaust ventilation to atmosphere as near to their source as possible.

Smoking should be prohibited in workshops where PTFE is handled because tobacco contaminated with PTFE will during burning give rise to polymer fumes. It is therefore important to avoid contamination of clothing, especially the pockets, with PTFE and to maintain a reasonable standard of personal cleanliness by washing hands and removing any PTFE particles lodged under the fingernails.

Laminated gaskets:-

The metal foil sheet used to reinforce gaskets is very thin and sharp. Care should be taken when handling to avoid the possibility of cuts or lacerations to fingers or hands.

1.6 Disposal

The product is recyclable. No ecological hazard is anticipated with disposal of this product providing due care is taken.

— 2. General product information —

2.1 Description

The 'C' series is a range of carbon steel (CE43), alloy steel (CE83) or stainless steel (CE63) two port, cage trim, control valves conforming to ANSI B 16.34 and ASME VIII standards. The valves are available in sizes 1" to 8" (DN25 to DN200), with ANSI and PN flange connections. When used in conjunction with a pneumatic linear actuator the 'C' series valve will provide characterised modulating or on/off control.

Note: For additional information see the relevant Technical Information Sheet.

Compatible actuators and positioners:

Pneumatic actuators	PN1000 series, spring-to-close
	PN2000 series, spring-to-open
Positioners	PP5 (pneumatic)
	EP5 (electropneumatic)
	SP2 (smart electropneumatic)

Refer to the relevant Technical Information Sheet for further details.

2.2 Sizes and pipe connections

1", 1½", 2", 2½", 3", 4", 5", 6" and 8" (DN25, 40, 50, 65, 80, 100, 125, 150 and 200).

Flanged to ANSI 150, ANSI 300, ANSI 600 (Raised face or ring type joint) or PN16, PN25, PN40, PN63, and PN100 (Raised face with ANSI face-to-face dimension).

1", 1½" and 2" socket weld.

2.3 Options

Trim	Equal %, linear, fast opening (on/off) characteristics, soft seat, hard faced, low noise and anti-cavitation (single and multi-cage).
Stem seal	PTFE chevron, graphite packing and bellows.
Plug	Balanced or unbalanced to ANSI Class IV, V or VI shut-off.

See 'C' series valve options Technical Information Sheet TI-F12-23.

2.4 Technical data

Plug design	Unbalanced plug		
	PTFE sealed balanced plug		
	Graphite sealed balanced plug		
Trim design	Cage trim with equal percentage, linear and fast opening flow characteristic options.		
Leakage	Class IV	Metal-to-metal seat	IEC 534-4
	Class IV & V	Hard face stellite	IEC 534-4
	Class VI	PTFE soft seat	IEC 534-4
Flow characteristic	CE valves	Equal percentage	
	CF valves	Fast opening	
	CL valves	Linear	
	CM valves	Modified equal percentage	
Rangeability	50:1 Equal percentage		
	30:1 Linear		
Travel	1" and 1½"	(DN25 and 40)	¾" (20 mm)
	2"	(DN50)	1⅜" (30 mm)
	2½" and 3"	(DN65 and 80)	1½" (38 mm)
	4"	(DN100)	2" (50 mm)
	5" and 6"	(DN125 and 150)	2½" (65 mm)
	8"	(DN200)	3" (75 mm)

2.5 Limiting conditions

Body design conditions		ANSI 300 and ANSI 600			
Design temperature	Standard PTFE chevron stem seals	CE43	14°F to +482°F	(-10°C to +250°C)	
		CE63	-20°F to +482°F	(-29°C to +250°C)	
		CE83	14°F to +482°F	(-10°C to +250°C)	
	Graphite packing stem seals	Standard bonnet	CE43	14°F to +572°F	(-10°C to +300°C)
			CE63	-20°F to +572°F	(-29°C to +300°C)
			CE83	14°F to +572°F	(-10°C to +300°C)
		Extended bonnet	CE43	14°F to +797°F	(-10°C to +425°C)
			CE63	-20°F to +1004°F	(-29°C to +540°C)
			CE83	14°F to +1004°F	(-10°C to +540°C)
	Graphite sealed balanced plug	Class IV	CE43	797°F	(425°C)
			CE63	1004°F	(540°C)
			CE83	1004°F	(540°C)
PTFE sealed balanced plug	Class VI		356°F	(180°C)	
Designed for a maximum cold hydraulic test pressure of:	ANSI 300	CE43	1110 psi g	(76.6 bar g)	
		CE63	1080 psi g	(74.5 bar g)	
		CE83	1125 psi g	(77.6 bar g)	
	ANSI 600	CE43	2220 psi g	(153.0 bar g)	
		CE63	2160 psi g	(149.0 bar g)	
		CE83	2250 psi g	(155.0 bar g)	

Maximum differential pressure See relevant actuator TI

2.6 Operating range for body material and flange type only.

Note: See limiting conditions for stem and plug limitations.

CE43 Carbon steel

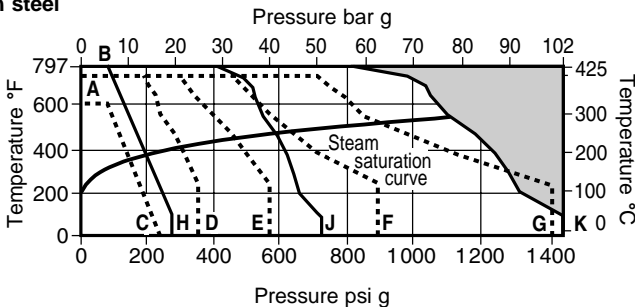

 The product must not be used in this region.

A-C PN16, A-D PN25, A-E PN40, A-F PN63, A-G PN100,
B-H ANSI 150, B-J ANSI 300, B-K ANSI 600

CE83 Alloy steel

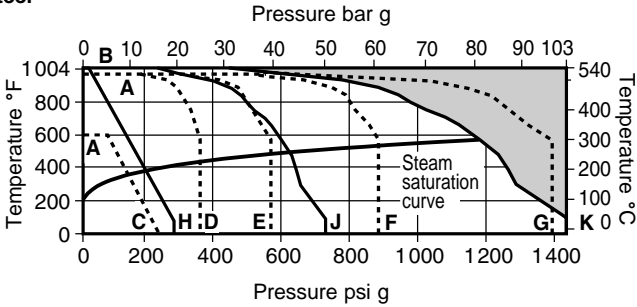

The product must not be used in this region.

A-C PN16, A-D PN25, A-E PN40, A-F PN63, A-G PN100,
 B-H ANSI 150, B-J ANSI 300, B-K ANSI 600

CE63 Stainless steel

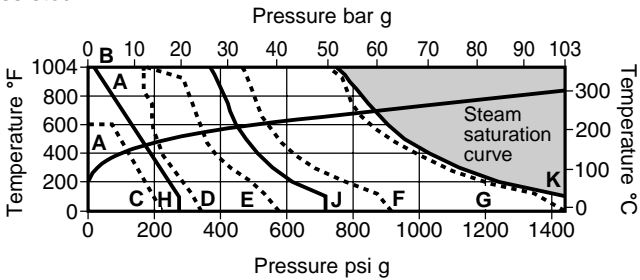

The product must not be used in this region.

A-C PN16, A-D PN25, A-E PN40, A-F PN63, A-G PN100,
 B-H ANSI 150, B-J ANSI 300, B-K ANSI 600

2.7 Weights (approximate) in lbs and (kg)

Valve size	1" DN25	1½" DN40	2" DN50	2½" DN65	3" DN80	4" DN100	5" DN125	6" DN150	8" DN200
Weights	29 (13)	48 (22)	59 (27)	92 (42)	130 (59)	213 (97)	264 (120)	396 (180)	660 (300)

2.8 Valve flow coefficients at 100% lift

C_v (US) for single stage trims (K_{VS} shown in brackets).

F_L = Flow recovery factor

Valve size	1" DN25	1½" DN40	2" DN50	2½" DN65	3" DN80	4" DN100	5" DN125	6" DN150	8" DN200
Equal % C _v (K _{VS})	19 (16)	35 (30)	63 (54)	95 (81)	130 (111)	216 (185)	293 (250)	385 (330)	560 (480)
F _L	0.94	0.94	0.94	0.94	0.90	0.89	0.85	0.85	0.85

Three reduced C_v are available for equal percentage and linear trims, for further details see: TI-F12-23, 'C' series valve options.

For conversion

$$C_v \text{ (UK)} = C_v \text{ (US)} \times 0.833$$

$$K_{VS} = C_v \text{ (US)} \times 0.855$$

2.9 Part numbers, description and materials

No.	Part	Material	
1	Body	CE43	Carbon steel ASTM A216 WCB
		CE63	Stainless steel ASTM A351 CF8M
		CE83	Alloy steel ASTM A217 WC6
2	Bonnet	CE43	Carbon steel ASTM A216 WCB
		CE63	Stainless steel ASTM A351 CF8M
		CE83	Alloy steel ASTM A217 WC6
3	Valve plug	Stainless steel	AISI 431 hardened
4	Valve cage	Stainless steel	AISI 316 ENC
5	Valve seat	Stainless steel	AISI 431
6	Valve stem	Stainless steel	AISI 316
7	Valve plug sealing rings	PTFE and graphite or graphite	
8	Lock-nut	Stainless steel	AISI 316
9	Mounting nut	Zinc plated carbon steel	
10	Gland spring	Stainless steel	AISI 302
11	Gland seal	PTFE chevron or graphite	
12	Bonnet gasket	Reinforced exfoliated graphite	
13	Bonnet studs	CE43	Carbon steel ASTM A193 B7
		CE63	Stainless steel ASTM A193 Gr. B8M
		CE83	Alloy steel ASTM A193 B16
14	Bonnet nuts	CE43	Carbon steel ASTM A194 2H
		CE63	Stainless steel ASTM A194 Gr. 8M
		CE83	Alloy steel ASTM A194 GRD4
15	Stuffing box studs	CE43	Carbon steel ASTM A193 B7
		CE63	Stainless steel ASTM A193 Gr. B8M
		CE83	Alloy steel ASTM A193 B16
16	Stuffing box nuts	CE43	Carbon steel ASTM A194 2H
		CE63	Stainless steel ASTM A194 Gr. 8M
		CE83	Alloy steel ASTM A194 GRD4
17	Stem scraper	Glass filled PTFE	
18	Stuffing box bush	Stainless steel	AISI 316
19	Stuffing box ring	Stainless steel	AISI 316
20	Valve stem wiper	Fluoroelastomer	
21	'O' ring	Fluoroelastomer	

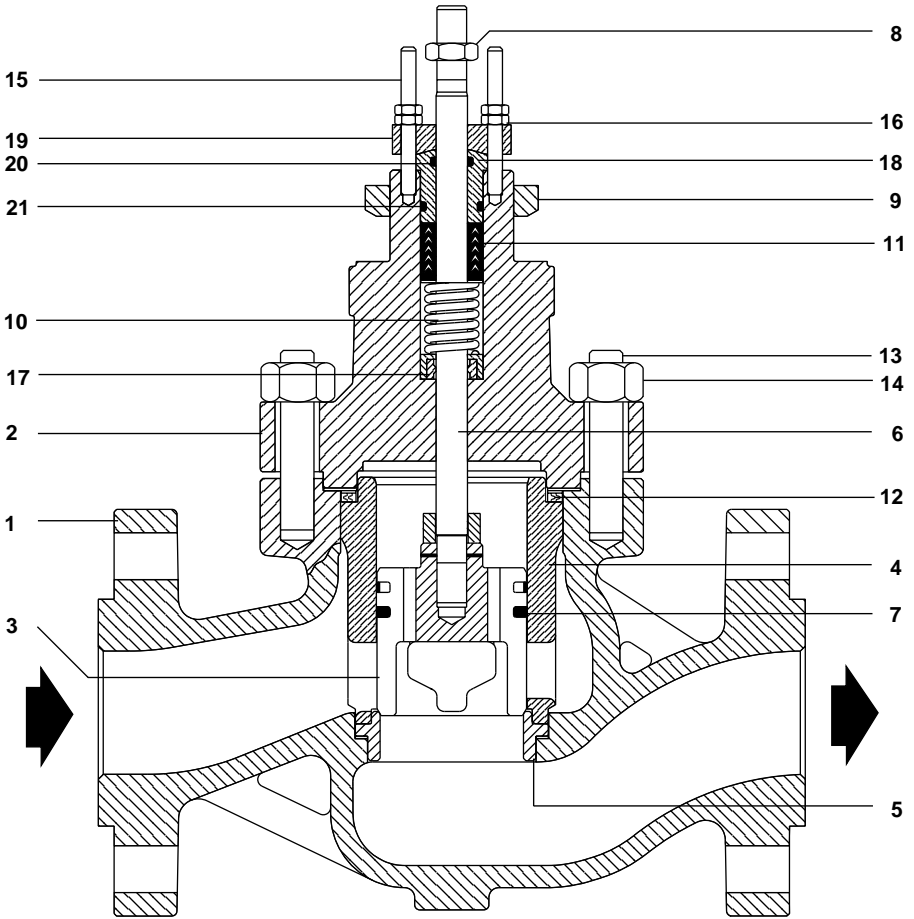

Fig. 1

— 3. Installation and Commissioning —

Note: Before actioning any installation, observe the 'Safety information' in Section 1.

3.1 General

The valve should be installed in such a position as to allow full access to the valve and actuator for maintenance purposes. Prior to fitting the valve the pipework should be flushed clear to remove any debris or other particles.

Remove the flange protectors and fit the valve into the pipeline taking notice of the direction of flow arrow on the valve body.

Care should be taken to prevent any strain being imposed on the valve body due to pipe misalignment. Tighten flange bolts evenly. Check flange bolts for tightness after 24 hours of operation. Care should be taken to ensure that the valve / actuator spindle is not painted or coated with any other substance.

When carrying out maintenance of the valve care should be taken to avoid damage to the valve plug, stem and seat.

3.2 Bypass arrangements

It is recommended that isolating valves be fitted upstream and downstream of the control valve. A bypass can be fitted around the valve with a manual regulating valve allowing the process to be controlled whilst the control valve is isolated for maintenance.

3.3 Commissioning

For commissioning instruction refer to the Installation and Maintenance Instructions, covering Spirax Sarco actuators.

4. Maintenance

Note: Before actioning any maintenance, observe the 'Safety information' in Section 1.

4.1 General

Valve parts are subject to normal wear and must be inspected and replaced as necessary. Inspection and maintenance frequency depends on the severity of service conditions. This Section gives instructions for packing lubrication, packing maintenance, trim maintenance, and bellows seal replacement. All maintenance operations can be performed with the valve body in the line.

4.2 Routine maintenance procedures

24 hours operation

After 24 hours service check pipework connections and flange bolts for tightness.

For valves which have high temperature graphite packed gland seals; the gland nut should be tightened by approximately $\frac{1}{4}$ of a turn taking care not to overtighten as this may cause excessive friction on the valve stem.

3 months operating intervals

After every 3 months normal service visually check gland seals for signs of leakage and if necessary take the following corrective action.

Valves having chevron gland seals remove and replace the PTFE chevron seal (refer to Section 4.3, page 10).

Valves having high temperature graphite packed gland seals tighten gland nut approximately $\frac{1}{4}$ of a turn taking care not to overtighten as this may cause excessive friction on the valve stem. If no adjustment is remaining, replace the graphite gland seal (refer to Section 4.4, page 12).

Annually

The valve should be inspected for wear and tear replacing any worn or damaged parts such as valve plug and stem, valve seat and gland seals. Refer to 'Spare parts' Section 5 for 'Available spares'.

High temperature graphite packed gland seals are subject to wear during normal operation. It is therefore recommended that the graphite packing is replaced during this routine inspection to prevent premature failure of the gland seals during normal operation.

4.3 Procedure for renewing chevron gland seals

For spring-loaded single PTFE chevron gland seals, the gland spring (10) maintains a sealing force on the packing. If leakage is noted around the stuffing box bush (18) check to be sure the shoulder on the bush is touching the bonnet. If the shoulder is not touching the bonnet, tighten the stuffing box nuts (16), until the shoulder is against the bonnet. If leakage cannot be stopped in this manner, the gland seals will need replacing.

If the leakage comes from the outside diameter of the seals, it is possible that the leakage is caused by damage to the stuffing box wall. If performing any of the following procedures, inspect the valve stem and packing box wall for damage.

4.3.1 Replacing chevron gland seals:

1. Isolate the control valve from the pressure, and release pressure from the valve body.
2. Disconnect the operating lines from the actuator and any leak-off piping from the bonnet. Disconnect the valve stem (6) from the actuator and then remove the actuator from the valve by unscrewing the mounting nut (9).
3. Loosen the stuffing box nuts (16) so that the seals are not tight on the valve stem. Remove the stem lock-nut (8) from the valve stem.

Caution:

When lifting the bonnet (2), be sure that the valve plug and stem assembly remains in the valve and on the seat. This will avoid damage to the seating surfaces as a result of the assembly dropping from the bonnet after being lifted part way out. The parts are also easier to handle separately.

4. Unscrew the bonnet nuts (14) and carefully lift the bonnet off the valve stem.
5. If the valve plug and stem assembly starts to lift with the bonnet, use a brass or lead hammer on the end of the stem and tap it back down. Put the bonnet onto a protective surface to prevent any damage to the bonnet gasket surface.
6. Cover the opening in the valve body to protect the gasket surface and prevent foreign material from getting into the body cavity.
7. Remove the stuffing box nuts (16), stuffing box ring (19), and stuffing box bush (18). Carefully push out all the remaining packing parts from the body side of the bonnet using a rounded rod or other tool that will not scratch the stuffing box wall. Clean the stuffing box and metal packing parts.
8. Inspect the valve stem threads and stuffing box surface for any sharp edges which might cut the packing. Scratches or burrs could cause damage to the new packing. If the surface condition cannot be improved by rolling with light emery paper, replace the damaged parts.
9. Remove the cover protecting the body cavity and install a new bonnet gasket set (F1, F2 and F3), making sure that the gasket seating surfaces are clean and smooth. Then slide the bonnet over the stem and onto the bonnet studs (13).

Note:

Proper tightening of the bonnet nuts compresses the bonnet gasket set (F1, F2 and F3) enough to both load and seal the seat ring gasket (F4). It also compresses the outer edge of the bonnet gasket enough to seal the body-to-bonnet joint.

Ensure that bolting threads are clean, and evenly tighten the nuts onto the studs in a diagonal pattern. Because of the bolt-up characteristics of spiral wound gaskets, a tightened nut may loosen an adjacent nut. Repeat the diagonal tightening pattern several times until each nut is tight and the body-to-bonnet seal is made. When the operating temperature has been reached, perform this torquing procedure once again.

10. Lubricate the studs (13) and tighten the nuts (14), using proper bolting procedures. (See Table 1 'Recommended tightening torques', page 18).
11. Tighten the stuffing box nuts (16) until the stuffing box ring (19) sits on the shoulder of the stuffing box bush (18).
12. Mount the actuator on the valve body assembly and reconnect the actuator and valve stem according to the procedure in the appropriate actuator Installation and Maintenance Instructions.

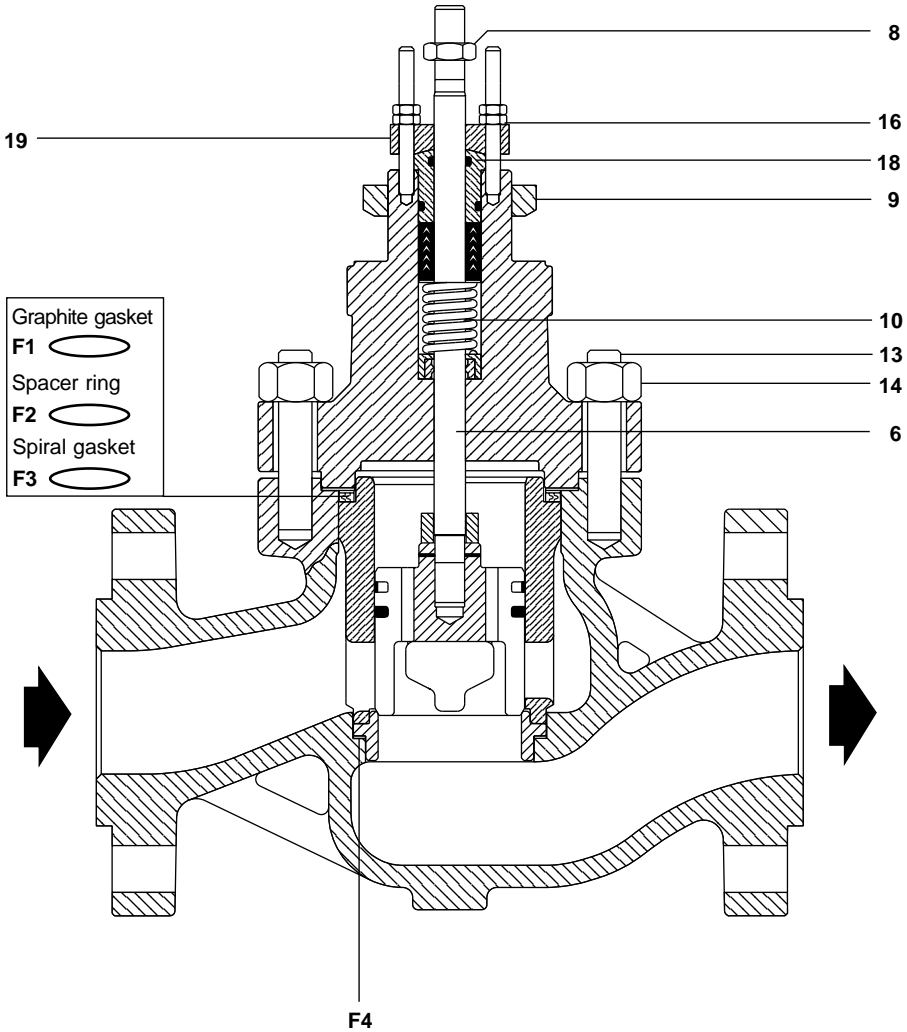

Fig. 2

4.4 Procedure for renewing graphite gland seals

If there is undesirable packing leakage first try to limit the leakage and establish a stem seal by tightening the stuffing box nuts (16).

Note: If the packing is relatively new and tight on the stem, and if tightening the stuffing box nuts does not stop the leakage, it is possible that the valve stem is worn or damaged so that a seal cannot be made.

4.4.1 Replacing graphite gland seals:

13. Copy Steps 1 to 10 in Section 4.3.1, (page 10), taking note when removing the belleville springs, of the position of each disc.
14. Install the packing components according to the order in Fig. 3.
Install the graphite rings (23) individually, by partially entering the ends together into the gland, before inserting the remainder of the ring. The ring should be pressed firmly to the bottom of the housing, using the follower and / or a spacer as required.
15. Install each of the remaining rings in the same way, ensuring that the join is staggered by at least 90° from the previous ring, and firmly push each ring into the gland.
16. Fit the packing follower (22), refit the belleville washers (25) following the original order, and stuffing box ring (19) into position. Lubricate the stuffing box nuts (16). Install and tighten the packing flange nuts finger tight.
17. Mount the actuator on the valve body assembly and reconnect the actuator and valve stem.
18. The packing should now be compressed by a nominal 10%. Mark a line on the follower 3 mm above the top of the gland housing. Then tighten the packing flange nuts, until the line on the follower reaches the top of the housing (See Figs. 3a and 3b opposite).
19. With the packing initially compressed to a nominal 10%, check the torque on the stuffing box nuts. At this point it is beneficial to perform at least 5 settling cycles, with the nut torque being restored during each cycle.
Therefore, operate the valve through approximately 5 cycles, and retorque the nuts at both the top and the bottom of the stroke.

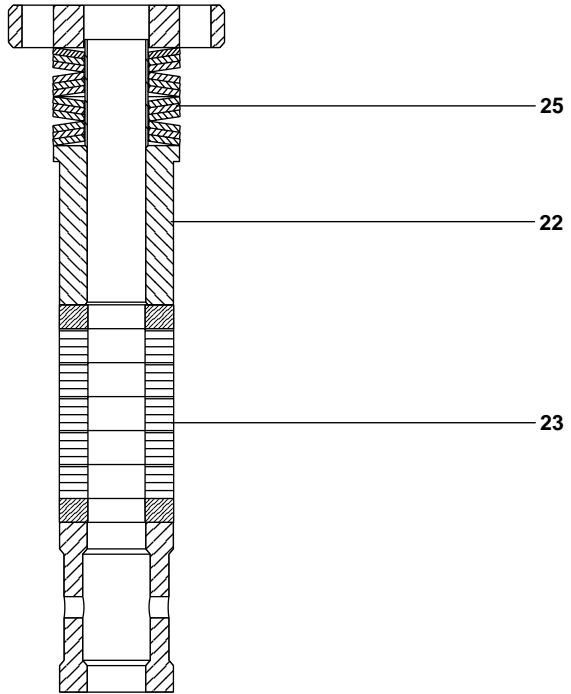

Fig. 3 Graphite gland seal assembly

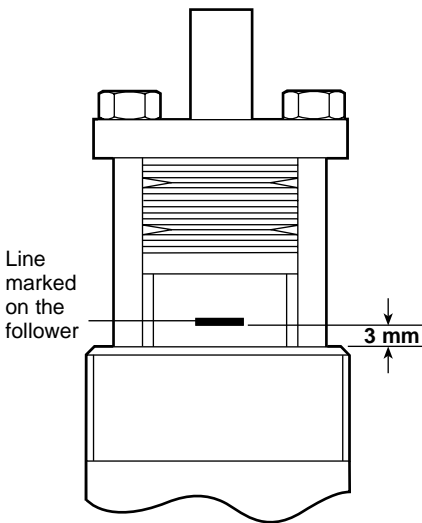

Fig. 3a

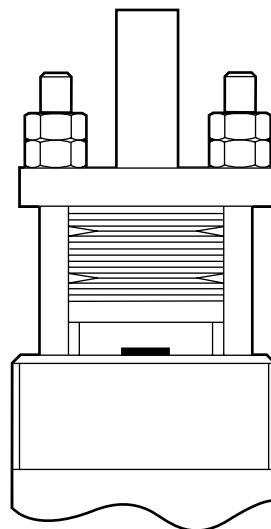

Fig. 3b

4.5 Trim maintenance

4.5.1 Disassembly of valves with standard bonnet and temperature extension bonnet:

1. Remove the actuator and the bonnet according to Steps 1 to 5 of the replacing chevron seals procedure (see Section 4.3.1, page 10).

Caution:

When lifting the valve plug stem (6) and attached valve plug (3) out of the body, be certain that the cage (4) remains in the body (1). This will prevent cage damage that might be caused by the cage dropping back into the body after being lifted part way out.

2. Packing parts can be removed if desired. Replace these parts as described in the replacing packing procedure, (see Section 4.3.1, page 10). Remove the cage adaptor (27) from any restricted-trim body, and wrap it for protection. The cage adaptor has two M6 screwed holes in which studs or bolts can be installed for lifting.
3. Lift the valve plug and stem assembly out of the valve body and set it on a protective surface. If the valve plug is to be reused, protect the valve plug seating surface to prevent any scratches.
4. Remove the cage and the associated gaskets (F1, F2 and F3), (see Fig. 4a).
5. Remove the seat (5) and seat gasket (F4).
6. Inspect parts for wear or damage which would prevent proper operation of the valve. Replace or repair trim parts according to the procedures for lapping seating surfaces or other valve plug maintenance procedures as appropriate (see Section 4.6).

4.5.2 Disassembly valves with bellows sealed bonnet (refer to Fig. 6):

1. Remove the actuator and the bonnet according to Steps 1 to 5 of the replacing chevron seals procedure (see Section 4.3.1, page 10).
2. Unscrew the nuts (14) securing the bonnet to the bellows housing (31) and remove the bonnet assembly.
3. Unscrew the nuts (30) securing the bellows housing to the valve body and remove the housing complete with stem and plug.
Carefully supporting the bellows housing, remove the pin fixing the valve head to the stem (26). Remove the valve head and the cage adaptor (27) (see Fig. 4b) for restricted trim valves and withdraw the stem / bellows assembly (18) from the bellows housing.
4. Remove the cage and the associated gaskets (F1, F2, and F3), (see Fig. 4a).
5. Remove the seat (5) and seat gasket (F4).
6. Inspect parts for wear or damage which would prevent proper operation of the valve. Replace or repair trim parts according to the procedures for lapping seating surfaces or other valve plug maintenance procedures as appropriate (see Section 4.6).

4.6 Lapping seating surfaces

Seating surfaces of the valve plug and seat ring (3 and 5) can be lapped for improved shut-off. (Deep nicks should be machined out rather than ground out). Use a commercial lapping compound or a mixture of 600-grit carborundum and solidified vegetable oil. Assemble the valve to the extent that the cage, and adaptor ring if used, and bonnet, is in place and the bonnet is bolted to the body. A simple handle can be made from a piece of steel strip locked to the valve plug stem with nuts.

Rotate the handle alternately in each direction to lap the seats. After lapping, remove the bonnet and clean the seat surfaces. Completely assemble as described in the trim maintenance procedure (Section 4.5) and test the valve for shut-off. Repeat the lapping procedure if leakage is still excessive.

Fig. 4 Extended bonnet

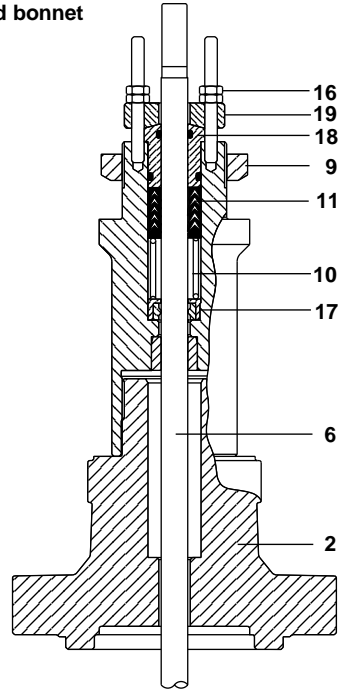

Fig. 4a 'C' Series valve

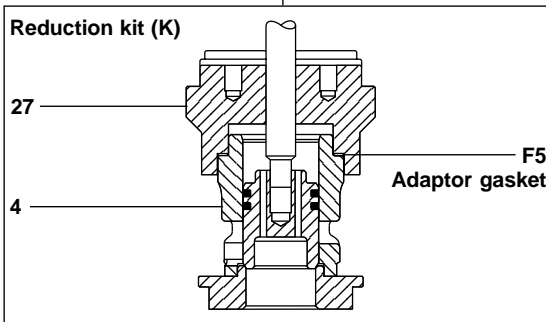
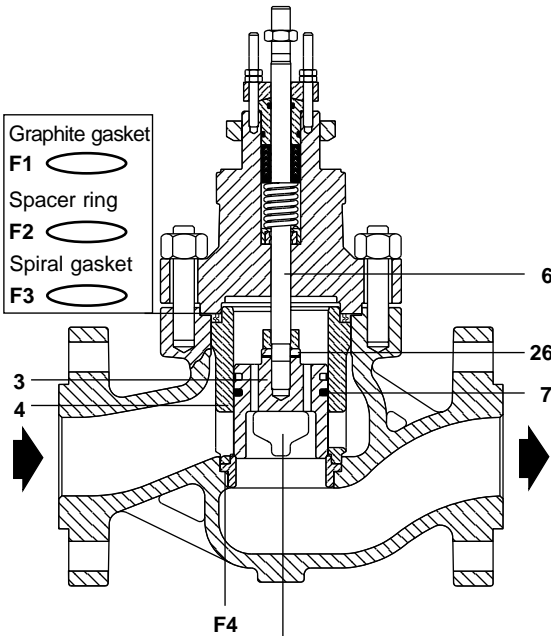

Fig. 4b Reduction kit

4.7 Valve plug and stem maintenance:

Caution:

If replacing the valve plug sealing rings (7), be careful not to scratch the surfaces of the ring grooves in the valve plug, the surfaces of the replacement ring, may not seal properly.

1. Remove the valve plug (3) in accordance with the instructions in trim maintenance, (see Section 4.5, page 14).
2. To replace the valve stem (6) drive out the groove pin (26) and unscrew the stem from the valve plug.
3. Screw the new stem into the valve plug. Tighten to the recommended torque see Table 1, page 18. Refer to Table 1 to select the proper drill size. Drill through the stem, using the hole in the valve plug as a guide. Remove any chips or burrs and drive in a new groove pin to lock the assembly.

4.7.1 Assembly standard and extension bonnet valves

1. Install the seat ring gasket (F4), and seat (5).
2. Install the cage (4). Rotation of the cage or assembly with respect to the body is acceptable.
3. Slide the valve plug (3) and stem assembly into the cage. Make sure the valve plug sealing rings (7) are evenly engaged in the entrance chamfer at the top of the cage (4) to avoid damaging the rings.
4. If a cage adaptor (27) is to be used, install the adaptor gasket (F5) and place it on top of the cage. Place the gaskets (F1, F2, and F3) on top of the cage or cage adaptor, (see Fig. 5).

Caution:

If the packing is to be reused and was not removed from the bonnet, use care when installing the bonnet to avoid damaging the packing with the valve stem threads.

5. Mount the bonnet on the body and complete assembly according to Steps 10 to 12 of the procedure for replacing chevron gland seals Section 4.3, page 10, omitting Step 11 if new packing is not being installed, and being sure to observe the 'Note' prior to Step 10.

4.7.2 Assembly bellows sealed bonnet valves

1. Install the seat gasket (F4), and seat (5), (see Fig. 5).
2. Install the cage (4). Rotation of the cage or assembly with respect to the body is acceptable. Place the gaskets (F1, F2, and F3) on top of the cage.
If a cage adaptor (27) is to be used, install the adaptor gasket (F5).
3. Insert replacement stem / bellows assembly (6) with new lower bellows flange gasket (29) ensuring that the anti-rotation pin (28) locates in the slot in the bellows housing (31) and taking great care not to damage the bellows. If a cage adaptor (27) is to be used, place it onto the stem before sliding on the gaskets (F1, F2 and F3).
4. Fit the valve plug (3) and the head pin (26). Peen the entrance to the head pin bore to prevent the pin working loose in operation.
By sliding the valve plug into the cage, refit the bellows housing (31) on the valve body. When the cage adaptor is used, fit it on the top of the cage.
Replace the nuts (14) and tighten to the recommended torque (see Table 1, page 18).
Using a new gasket (32) refit the bonnet (2) on the bellows housing (31). Replace the four nuts (30) and tighten to the recommended torque (see Table 1, page 18).

Caution:

If the packing is to be reused and was not removed from the bonnet, use care when installing the bonnet to avoid damaging the packing with the valve stem threads.

5. Mount the bonnet on the body and complete assembly according to Steps 10 to 14 of the procedure for replacing chevron gland seals Section 4.3, page 10, omitting Steps 11 and 12 if new packing is not being installed, and being sure to observe the 'Note' prior to Step 10.

Fig. 5 'C' Series valve

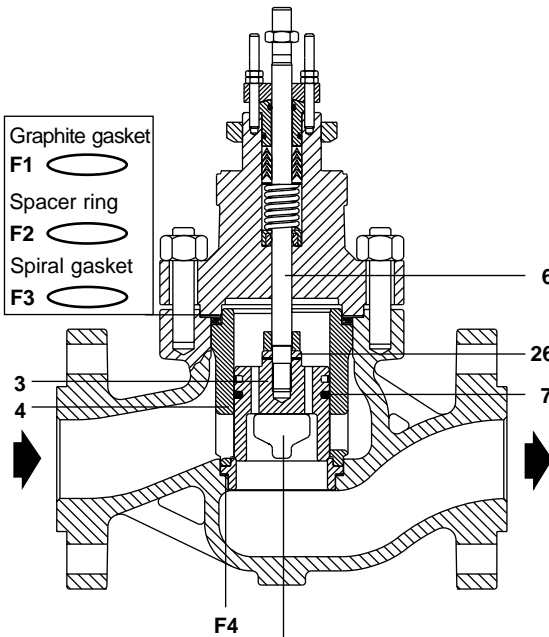
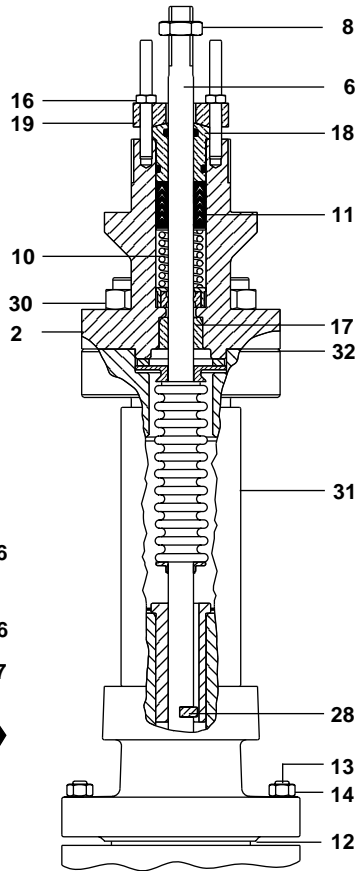
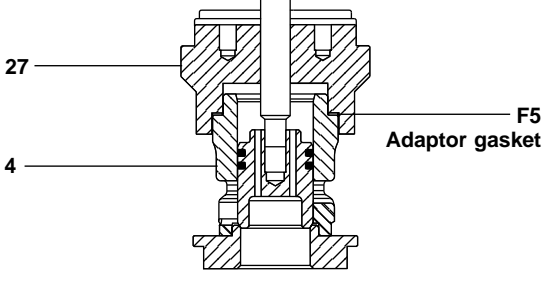

Fig. 6 Bellows sealed bonnet



Reduction kit (K)



5. Spare parts

The spare parts available for the CE43, CE63 and CE83 valves, 1" to 8" (DN25 to DN200), are detailed below. No other parts are supplied as spares.

Available spares

Actuator clamping nut		A	
Gland seal kit	PTFE seal set	B	
	Graphite packing set	C	
Valve plug		D	
Valve stem		E	
Valve gasket kit	Graphite gasket	F1	
	Bonnet	Spacer	F2
		Spiral wound gasket	F3
	Seat		F4
	Adaptor gasket		F5
Piston seal kit	Graphite	G	
	PTFE	H	
Valve seat		I	
Valve cage		J	
Reduction kit (seat, cage and reduction adaptor)		K	

Note: A 'valve gasket kit' should be ordered with the above items.

Table 1 Recommended tightening torques

Bonnet nuts (14)

Valve size	Nut size	Nut torque lbf ft (N m) minimum to maximum	
1"	½"	22.1 to 29.5	(30.0 to 40.0)
1½"	⅝"	38.3 to 45.7	(52.0 to 62.0)
2"	⅝"	46.8 to 54.2	(63.5 to 73.5)
2½"	¾"	81.5 to 96.2	(110.5 to 130.5)
3"	¾"	72.6 to 87.4	(98.5 to 118.5)
4"	⅞"	116.5 to 131.3	(158.0 to 178.0)
5"	⅞"	140.1 to 154.9	(190.0 to 210.0)
6"	1"	169.6 to 184.4	(230.0 to 250.0)
8"	1⅛"	184.4 to 199.1	(250.0 to 270.0)

Valve stem to plug connection

Valve stem size ins (mm)	Bolt torque min. to max. lbf ft (N m)	Groove pin replacement Drill size ins (mm)
½" (12.7)	59.0 to 73.7 (80 to 100)	0.08" (2)
¾" (20.0)	169.6 to 199.1 (230 to 270)	0.08" (2)

Bellows seal bonnet packing flange nuts (30)

Valve size	Bolt torque min. to max. lb ft (N m)
1" to 4"	36.9 to 44.3 (50 to 60)
5" to 8"	51.6 to 59.0 (70 to 80)

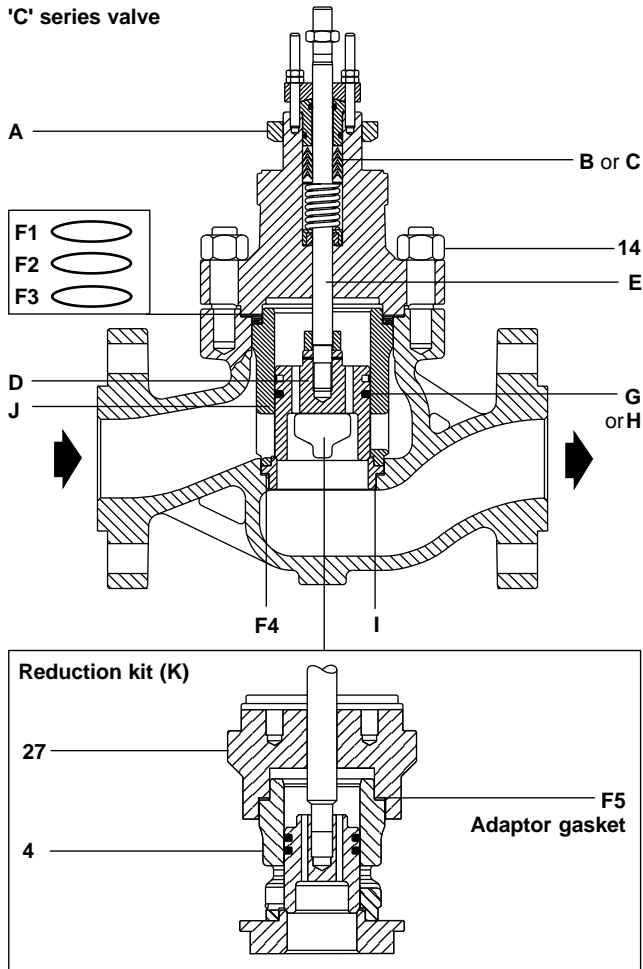

Fig. 7 Spare parts

Note:

When placing an order for spares please indicate clearly the product code, serial number and date code (found on the label of the valve body) to ensure that the order is processed quickly, efficiently and correctly.

How to order spares

Always order spares by using the description given in the column headed 'Available spares'. Also state the information shown in the 'C' series valve selection guide (See page 20), the serial number, and date code of the valve.

'C' series valve selection guide

Valve size	1", 1½", 2", 2½", 3", 4", 5", 6" and 8" DN25, 40, 50, 65, 80, 100, 125, 150 and 200	2"
Valve series	C = Cage trim	C
Valve characteristic	E = Equal percentage F = Fast opening L = Linear M = Modified equal percentage	E
Body material	4 = Carbon steel 6 = Stainless steel 8 = Alloy steel	4
Connections	2 = Butt weld (2" to 8") 3 = Flanged 4 = Socket weld (1", 1½" and 2")	3
Stem sealing options	P = PTFE chevron H = Graphite B = Bellows	P
Seating options	T = AISI 431 hardened G = PTFE soft seat W = Hard faced stellite AISI 316	T
Type of trim	C = Standard cage P = Noise reducing perforated cage A = Anti-cavitation cage	C
Number of stages	1 = One 2 = Two 3 = Three Other = To be specified	1
Trim balancing	B = Balanced U = Unbalanced	U
Bonnet type	S = Standard H = Extended for high temperature L = Extended for low temperature	S
Reduced trim	0 = No reductions 1 = 1 Reduction 2 = 2 Reductions 3 = 3 Reductions	1
C_v	To be specified	C_v 35
Connection type	To be specified	ANSI 300

2" **C** **E** **4** **3** **P** **T** **C** **1** **U** **S** **1** **C_v 35** **ANSI 300**

How to order

Example: 1 off 2" CE43PTC1US1 C_v 35 flanged to ANSI 300.