

BT6-B

Sanitary Balanced Pressure Thermostatic Steam Trap
Installation and Maintenance Instructions

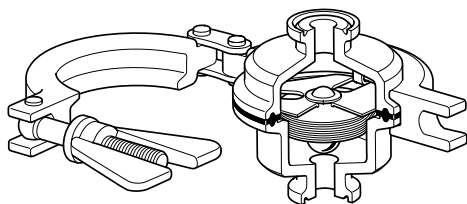

1. Safety information
2. General Product information
3. Installation
4. Commissioning
5. Operation
6. Spare parts and Maintenance

1. Safety information

Safe operation of these products can only be guaranteed if they are properly installed, commissioned, used and maintained by qualified personnel (see Section 1.11) in compliance with the operating instructions. General installation and safety instructions for pipeline and plant construction, as well as the proper use of tools and safety equipment must also be complied with.

1.1 Intended use

Referring to the Installation and Maintenance Instructions, name-plate and Technical Information Sheet, check that the product is suitable for the intended use / application. The products listed below comply with the requirements of the European Pressure Equipment Directive 97/23/EC and all fall within category 'SEP'. It should be noted that products within this category are required by the Directive not to carry the CE mark.

- i) The product has been specifically designed for use on steam, air or water / condensate which is in Group 2 of the above mentioned Pressure Equipment Directive. The products' use on other fluids may be possible but, if this is contemplated, Spirax Sarco should be contacted to confirm the suitability of the product for the application being considered.
- ii) Check material suitability, pressure and temperature and their maximum and minimum values. If the maximum operating limits of the product are lower than those of the system in which it is being fitted, or if malfunction of the product could result in a dangerous overpressure or overtemperature occurrence, ensure a safety device is included in the system to prevent such over-limit situations.
- iii) Determine the correct installation situation and direction of fluid flow.
- iv) Spirax Sarco products are not intended to withstand external stresses that maybe induced by any system to which they are fitted. It is the responsibility of the installer to consider these stresses and take adequate precautions to minimise them.
- v) Remove protective covers from all connections and protective film from all name-plates, where appropriate, before installation on a steam or other high temperature applications.

1.2 Access

Ensure safe access and if necessary a safe working platform (suitably guarded) before attempting to work on the product. Arrange suitable lifting gear if required.

1.3 Lighting

Ensure adequate lighting, particularly where detailed or intricate work is required.

1.4 Hazardous liquids or gases in the pipeline

Consider what is in the pipeline or what may have been in the pipeline at some previous time. Consider: flammable materials, substances hazardous to health, extremes of temperature.

1.5 Hazardous environment around the product

Consider: explosion risk areas, lack of oxygen (e.g. tanks, pits), dangerous gases, extremes of temperature, hot surfaces, fire hazard (e.g. during welding), excessive noise, moving machinery.

1.6 The system

Consider the effect on the complete system of the work proposed. Will any proposed action (e.g. closing isolation valves, electrical isolation) put any other part of the system or any personnel at risk?

Dangers might include isolation of vents or protective devices or the rendering ineffective of controls or alarms. Ensure isolation valves are turned on and off in a gradual way to avoid system shocks.

1.7 Pressure systems

Ensure that any pressure is isolated and safely vented to atmospheric pressure. Consider double isolation (double block and bleed) and the locking or labelling of closed valves. Do not assume that the system has depressurised even when the pressure gauge indicates zero.

1.8 Temperature

Allow time for temperature to normalise after isolation to avoid danger of burns. If parts made from Viton have been subjected to a temperature approaching 315°C (599°F) or higher, they may have decomposed and formed hydrofluoric acid. Avoid skin contact and inhalation of any fumes as the acid will cause deep skin burns and damage the respiratory system.

If parts made from PTFE have been subjected to a temperature approaching 260°C (500°F) or higher, they will give off toxic fumes, which if inhaled are likely to cause temporary discomfort. It is essential for a no smoking rule to be enforced in all areas where PTFE is stored, handled, or processed as persons inhaling the fumes from burning tobacco contaminated with PTFE particles can develop 'polymer fume fever'.

1.9 Tools and consumables

Before starting work ensure that you have suitable tools and/or consumables available. Use only genuine Spirax Sarco replacement parts.

1.10 Protective clothing

Consider whether you and/or others in the vicinity require any protective clothing to protect against the hazards of, for example, chemicals, high/low temperature, radiation, noise, falling objects, and dangers to eyes and face.

1.11 Permits to work

All work must be carried out or be supervised by a suitably competent person. Installation and operating personnel should be trained in the correct use of the product according to the Installation and Maintenance Instructions.

Where a formal 'permit to work' system is in force it must be complied with. Where there is no such system, it is recommended that a responsible person should know what work is going on and, where necessary, arrange to have an assistant whose primary responsibility is safety.

Post 'warning notices' if necessary.

1.12 Handling

Manual handling of large and / or heavy products may present a risk of injury. Lifting, pushing, pulling, carrying or supporting a load by bodily force can cause injury particularly to the back. You are advised to assess the risks taking into account the task, the individual, the load and the working environment and use the appropriate handling method depending on the circumstances of the work being done. Please refer to Section 6.2 for additional information on product handling.

1.13 Residual hazards

In normal use the external surface of the product may be very hot. If used at the maximum permitted operating conditions the surface temperature of some products may reach temperatures in excess of 177°C (350°F).

Take due care when dismantling or removing the product from an installation (refer to Section 6 'Maintenance instructions').

1.14 Freezing

Provision must be made to protect systems which are not self-draining against frost damage in environments where they may be exposed to temperatures below freezing point.

1.15 Disposal

Unless otherwise stated in the Installation and Maintenance Instructions, this product is recyclable and no ecological hazard is anticipated with its disposal providing due care is taken.

Viton:

- Can be landfilled, when in compliance with National and Local regulations.
- Can be incinerated, but a scrubber must be used to remove Hydrogen Flouride, which is evolved from the product and with compliance to National and Local regulations.
- Is insoluble in aquatic media.

PTFE:

- Can only be disposed of by approved methods, not incineration.
- Keep PTFE waste in a separate container do not mix it with other rubbish, and consign it to a landfill site.

1.16 Returning products

Customers and stockists are reminded that under EC Health, Safety and Environment Law, when returning products to Spirax Sarco they must provide information on any hazards and the precautions to be taken due to contamination residues or mechanical damage which may present a health, safety or environmental risk. This information must be provided in writing including Health and Safety data sheets relating to any substances identified as hazardous or potentially hazardous.

2. General product information

2.1 Description

The Spirax Sarco BT6-B sanitary balanced pressure thermostatic steam trap is designed to remove condensate from clean and pure steam applications with minimal condensate retention. Applications include sterile steam barriers, block and bleed installations, mains drainage and CIP/SIP of vessels and reactors and process lines. Manufactured in 316L, the crevice free body design of the BT6-B incorporates a 15° angled seat to ensure full drainability. The standard element is extremely sensitive to changes in condensate temperature and is designed to open with a minimum of sub-cooling, less than 2°C from steam saturation temperature at pressures below 2.5 bar g for typical operating conditions, exact operating performance may be affected by operating pressure, installation and ambient conditions. Each trap is individually packaged within a 'clean' environment with protective end caps and sealed in a protective plastic bag.

Available types

| | |
|---------------|---------------|
| BT6-BL | Low capacity |
| BT6-BH | High capacity |

Body surface finish (measured to ISO 4287-1997 and ISO 4288-1997):

- Internal surfaces have a finish of 0.6 µm (25 micro-inch Ra, ASME BPE SFV2).
- External surfaces have a finish of 1.0 µm (40 micro-inch Ra).

Options:

- Mechanical and electropolishing to 0.375 µm (15 micro-inch Ra, ASME BPE SFV4).
- For applications requiring closer to steam saturation temperatures, for example, critical SIP applications, please consult Spirax Sarco.

Standard

This product fully complies with ASME BPE and the requirements of the European Pressure Equipment Directive 97/23/EC.

All seals comply with FDA CFR title 21, part 177, section 1550 and USP class VI sections 87 and 88, ADI (Animal Derived Ingredient free).

Certification

This product is available with the following certification:

- EN 10204 3.1 material certificates.
- Typical internal surface finish certificates.
- Certificate of conformity of the seal for FDA, USP and ADI.

Note: All certification / inspection requirements must be stated at the time of order placement.

Note: For further product data see the following Technical Information Sheet, TI-P180-30.

2.2 Sizes and pipe connections

½", ¾", 1" and 1½" sanitary clamp ends to ASME BPE.

For other end connections please consult Spirax Sarco.

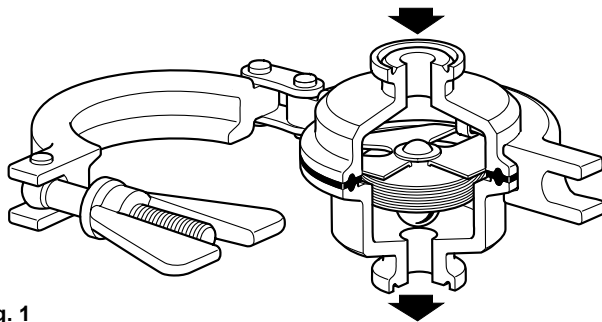
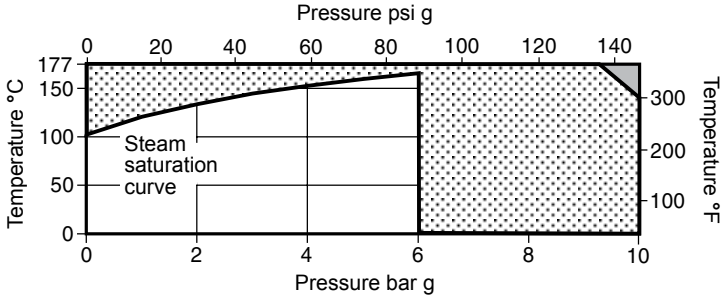



Fig. 1

2.3 Pressure / temperature limits (ISO 6552)



 The product **must not** be used in this region.

 The product should not be used in this region as damage to the internals may occur.

Note: For hygienic/sanitary clamp ends the maximum pressure / temperature may be restricted by the gasket or sanitary clamp used. Please consult Spirax Sarco.

| | | | |
|---|--|-------------------|----------------------|
| Body design condition | | | PN10 |
| PMA | Maximum allowable pressure | 10 bar g @ 140°C | (145 psi g @ 284°F) |
| TMA | Maximum allowable temperature | 177°C @ 9.2 bar g | (350°F @ 133 psi g) |
| Minimum allowable temperature | | -254°C | (-425°F) |
| PMO | Maximum operating pressure for saturated steam service | 6 bar g | (87 psi g) |
| TMO | Maximum operating temperature | 165°C @ 6 bar g | (329°F @ 87 psi g) |
| Minimum operating temperature | | 0°C | (32°F) |
| Designed for a maximum cold hydraulic test pressure of: | | | 15 bar g (218 psi g) |

3. Installation

Note: Before actioning any installation observe the 'Safety information' in Section 1.

Referring to the Installation and Maintenance Instructions, name-plate and Technical Information Sheet, check that the product is suitable for the intended installation:

- 3.1** Check materials, pressure and temperature and their maximum values. If the maximum operating limit of the product is lower than that of the system in which it is being fitted, ensure that a safety device is included in the system to prevent overpressurisation.
- 3.2** Determine the correct installation situation and the direction of fluid flow.
- 3.3** Remove protective covers from all connections and protective film from all name-plates, where appropriate, before installation on a steam or other high temperature applications.
- 3.4** The trap is designed to be fitted in **vertical lines** with flow downwards so that it can be self-draining. Check flow arrow for correct orientation. Fittings, clamps and gaskets for pipe end connections are not supplied. Do not expose the element to superheat conditions since over expansion may result.

Installation should include a suitable cooling leg to avoid condensate back-up into process equipment under normal operating conditions.

Caution: Do not overtighten clamp. This may cause the seal to spread/extrude and interface with element frame. **It is normally only necessary to take up slack and tighten the nut by half a turn maximum.**

Note: The body and element must be handled carefully to ensure that the machined surfaces are not damaged.

Note: If the trap is to discharge to atmosphere ensure it is to a safe place, the discharging fluid may be at a temperature of 100°C (212°F).

4. Commissioning

After installation or maintenance ensure that the system is fully functioning. Carry out tests on any alarms or protective devices.

Note: As with all steam systems it is very important that the pressure is built up slowly to avoid possible damage to any sensitive equipment.

5. Operation

The operation relies on a stainless steel capsule that is filled with a temperature sensing fluid. During cold or start-up conditions the capsule will be fully open allowing large volumes of air, condensate and/or CIP fluid to be drained. As the system approaches steam temperature the fluid in the capsule expands and the valve closes the trap to prevent live steam loss. This closure occurs very close to steam temperature to ensure efficient drainage of the system.

6. Spare parts and maintenance

Note: Before actioning any maintenance programme observe the 'Safety information' in Section 1.

6.1 Spare parts

These are the available spare parts. No other parts are supplied as spares.

| | |
|------------------------------|---------|
| Capsule element assembly | 3 and 5 |
| Seal | 5 |
| Body (outlet) including seat | 2 |

How to order spares

Always order spares by using the description given in the column headed 'Available spares' and state the size and type of trap.

Example: 1 - Capsule element assembly for a 1/2" BT6-BH sanitary balanced pressure thermostatic steam trap.

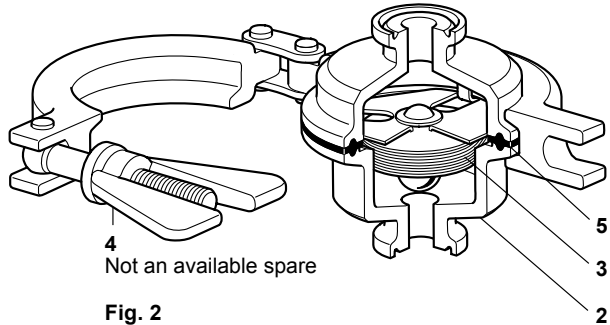

Fig. 2

6.2 Maintenance

Before undertaking any maintenance on the trap it must be isolated from the supply line and return line and any pressure allowed to slowly normalise to atmosphere. The trap assembly should then be allowed to cool.

Note: Damage to the capsule element assembly will occur if the body clamp is removed before the trap has cooled to 60°C or below.

Note: The body and element must be handled carefully to ensure that the machined surfaces are not damaged.

Remove the sanitary clamps from the pipeline connections and remove the whole trap from the pipeline. Remove the body sanitary clamp (4), then the trap inlet and outlet body including the seat (2), seal (5) and capsule element assembly (3) can be removed for cleaning or replacement. Reassemble using a new seal and with the valve head in position to close onto the seat orifice. Replace and tighten sanitary clamps and put back into service. Check for leaks and retighten as necessary.

Note: On occasions the gasket can be difficult to remove from the metal parts. The element mounting plate can bond to the gasket. To avoid damage, do not attempt to pull the element away by levering or pulling the welded capsule. Instead gently prise the gasket from the valve body as shown in C below.



A



B



C



D

Reassemble using a new seal and with the valve head in position to close onto the seat orifice. Replace and tighten sanitary clamps and put back into service. Check for leaks and retighten as necessary.