

SA Control Valve types:**BM, BMF, BX, SB, NS, KA, KB, KC (Normally open)****BMRA, BMFRA, BXRA, SBRA, NSRA, KX, KY (Normally closed)****Installation and Maintenance Instructions**

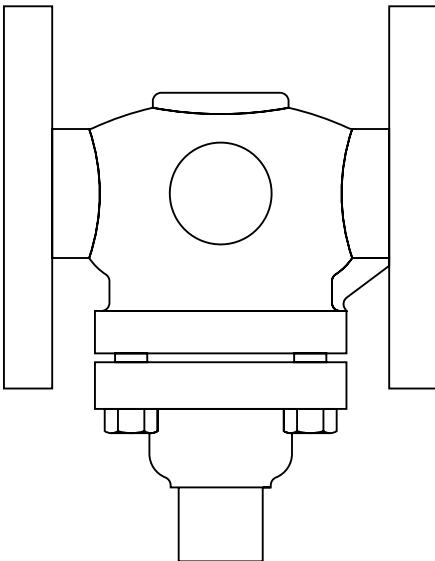

- 1. General safety information*
- 2. Technical details*
- 3. Installation and commissioning*
- 4. Maintenance*
- 5. Spare parts*

1. General safety information

Safe operation of these products can only be guaranteed if they are properly installed, commissioned, used and maintained by qualified personnel (see Section 1.11) in compliance with the operating instructions. General installation and safety instructions for pipeline and plant construction, as well as the proper use of tools and safety equipment must also be complied with.

Warning - Laminated gaskets

The metal foil sheet used to reinforce gaskets is very thin and sharp. Care should be taken when handling to avoid the possibility of cuts or lacerations to fingers or hands.

1.1 Intended use

Referring to the Installation and Maintenance Instructions, name-plate and Technical Information Sheet, check that the product is suitable for the intended use/application. The products listed below comply with the requirements of the European Pressure Equipment Directive 97/23/EC and carry the CE mark when so required. The products fall within the following Pressure Equipment Directive categories:

Product	Group 2 Gases	Group 2 Liquids
BX, BXRA, BM, BMRA, BMF, BMFRA, SB and SBRA	SEP	SEP
KA, KB, KC, KX, KY31 and KY33	SEP	SEP
KA, KB, KC, KX and KY43	DN15 - 32	SEP
	DN40 - 50	1
KA, KB, KC, KX and KY51	DN15 - 40	SEP
	DN50	1
KA61, KA63 and KC63	DN15 - 32	SEP
KA and KC63	DN40 - 50	1
NS and NSRA	1	SEP

- i) The products have been specifically designed for use on steam, water and other non-hazardous fluids which are in Group 2 of the above mentioned Pressure Equipment Directive. The products' use on other fluids may be possible but, if this is contemplated, Spirax Sarco should be contacted to confirm the suitability of the product for the application being considered.
- ii) Check material suitability, pressure and temperature and their maximum and minimum values. If the maximum operating limits of the product are lower than those of the system in which it is being fitted, or if malfunction of the product could result in a dangerous overpressure or overtemperature occurrence, ensure a safety device is included in the system to prevent such over-limit situations.
- iii) Determine the correct installation situation and direction of fluid flow.
- iv) Spirax Sarco products are not intended to withstand external stresses that may be induced by any system to which they are fitted. It is the responsibility of the installer to consider these stresses and take adequate precautions to minimise them.
- v) Remove protection covers from all connections before installation.

1.2 Access

Ensure safe access and if necessary a safe working platform (suitably guarded) before attempting to work on the product. Arrange suitable lifting gear if required.

1.3 Lighting

Ensure adequate lighting, particularly where detailed or intricate work is required.

1.4 Hazardous liquids or gases in the pipeline

Consider what is in the pipeline or what may have been in the pipeline at some previous time. Consider: flammable materials, substances hazardous to health, extremes of temperature.

1.5 Hazardous environment around the product

Consider: explosion risk areas, lack of oxygen (e.g. tanks, pits), dangerous gases, extremes of temperature, hot surfaces, fire hazard (e.g. during welding), excessive noise, moving machinery.

1.6 The system

Consider the effect on the complete system of the work proposed. Will any proposed action (e.g. closing isolation valves, electrical isolation) put any other part of the system or any personnel at risk?

Dangers might include isolation of vents or protective devices or the rendering ineffective of controls or alarms. Ensure isolation valves are turned on and off in a gradual way to avoid system shocks.

1.7 Pressure systems

Ensure that any pressure is isolated and safely vented to atmospheric pressure. Consider double isolation (double block and bleed) and the locking or labelling of closed valves. Do not assume that the system has depressurised even when the pressure gauge indicates zero.

1.8 Temperature

Allow time for temperature to normalise after isolation to avoid danger of burns.

1.9 Tools and consumables

Before starting work ensure that you have suitable tools and/or consumables available. Use only genuine Spirax Sarco replacement parts.

1.10 Protective clothing

Consider whether you and/or others in the vicinity require any protective clothing to protect against the hazards of, for example, chemicals, high/low temperature, radiation, noise, falling objects, and dangers to eyes and face.

1.11 Permits to work

All work must be carried out or be supervised by a suitably competent person. Installation and operating personnel should be trained in the correct use of the product according to the Installation and Maintenance Instructions.

Where a formal 'permit to work' system is in force it must be complied with. Where there is no such system, it is recommended that a responsible person should know what work is going on and, where necessary, arrange to have an assistant whose primary responsibility is safety.

Post 'warning notices' if necessary.

1.12 Handling

Manual handling of large and/or heavy products may present a risk of injury. Lifting, pushing, pulling, carrying or supporting a load by bodily force can cause injury particularly to the back. You are advised to assess the risks taking into account the task, the individual, the load and the working environment and use the appropriate handling method depending on the circumstances of the work being done.

1.13 Residual hazards

In normal use the external surface of the product may be very hot. If used at the maximum permitted operating conditions the surface temperature of some products may reach temperatures of 300°C (572°F).

Many products are not self-draining. Take due care when dismantling or removing the product from an installation (refer to 'Maintenance instructions').

1.14 Freezing

Provision must be made to protect products which are not self-draining against frost damage in environments where they may be exposed to temperatures below freezing point.

1.15 Disposal

Unless otherwise stated in the Installation and Maintenance Instructions, this product is recyclable and no ecological hazard is anticipated with its disposal providing due care is taken.

1.16 Returning products

Customers and stockists are reminded that under EC Health, Safety and Environment Law, when returning products to Spirax Sarco they must provide information on any hazards and the precautions to be taken due to contamination residues or mechanical damage which may present a health, safety or environmental risk. This information must be provided in writing including Health and Safety data sheets relating to any substances identified as hazardous or potentially hazardous.

2. Technical details

See the following Technical Information Sheets, for full details of: Materials, sizes and pipe connections, dimensions, weights, operating ranges, capacities and spare parts.

SA control valve	TI reference
BM, BMRA, BMF and BMFRA	TI-P036-01
BX, BXRA	TI-P036-02
SB, SBRA	TI-P044-01
NS, NSRA	TI-P049-01
KX31, KX33, KY31 and KY33	TI-P078-01
KA31, KA33, KB31, KB33 and KC31	TI-P078-02
KX51 and KY51	TI-P078-03
KA51, KB51 and KC51	TI-P078-04
KX43 and KY43	TI-P078-05
KA43, KB43 and KC43	TI-P078-06
KA61, KA63 and KC63	TI-P078-08

Copies of the above are available on request.

— 3. Installation and commissioning —

Note: Before actioning any installation observe the 'Safety information' in Section 1.

Important note

The valves covered by these instructions are for use with Spirax Sarco EL and SA control systems Types 121, 122, 123 and 128. (The Types 122 and 128 SA control system are not suitable for valves above 1"/DN25).

3.1 General installation

The valve should always be fitted in a horizontal pipeline with the flow in the direction indicated by the arrow marked on the body with the sensor in a vertical plane below the pipeline as shown in Figure 1 (SA control system). Valves should be mounted in the pipeline in accordance with the actuator Installation and Maintenance Instructions.

A suitable strainer should always be fitted upstream of the valve. Additionally on steam installations a separator should be fitted before the valve, plus a steam trap set on applications where condensate may accumulate upstream of the valve.

Warning:

The SA control system actuator must be securely connected to the valve via the screwed connection on the bottom of the valve and the half union coupling on the actuator before any fluid is allowed to pass through the valve.

Similarly, the actuator should not be disconnected from the valve until the valve itself is fully isolated.

It is important that line stresses i.e. expansion or inadequate supporting of the pipe are not imposed on the valve body.

If the valve is properly sized for the duty it has to perform it will often be smaller than the pipeline. This is particularly so where the medium passing through the valve is steam, in which case any reduction in line size should be made using eccentric reducers. The piping on both upstream and downstream sides of the valve must be of ample size to avoid undue pressure drop in the line and any reduction to meet the size of the valve should be made close to the valves as shown in Figure 1.

It is advisable to protect the valve by fitting a strainer on the upstream side. By fitting the strainer on its side where the medium is steam you will prevent the body filling with water which would reduce the screening area.

In most steam installations, water formed by condensation due to radiation losses will be present in the upstream pipeline and should be removed by an adequate drain point and trap, as shown in Figure 1.

3.2 Bypass arrangements

It is recommended that isolating valves be fitted upstream and downstream of the control valve together with a manual regulating valve to bypass the group (see the dotted pipework, Figure 1). The process may then be controlled by the bypass valve while the control valve is isolated for maintenance purposes.

3.3 Commissioning

For commissioning instructions refer to the Operation, Installation and Maintenance Instructions, covering Spirax Sarco control systems.

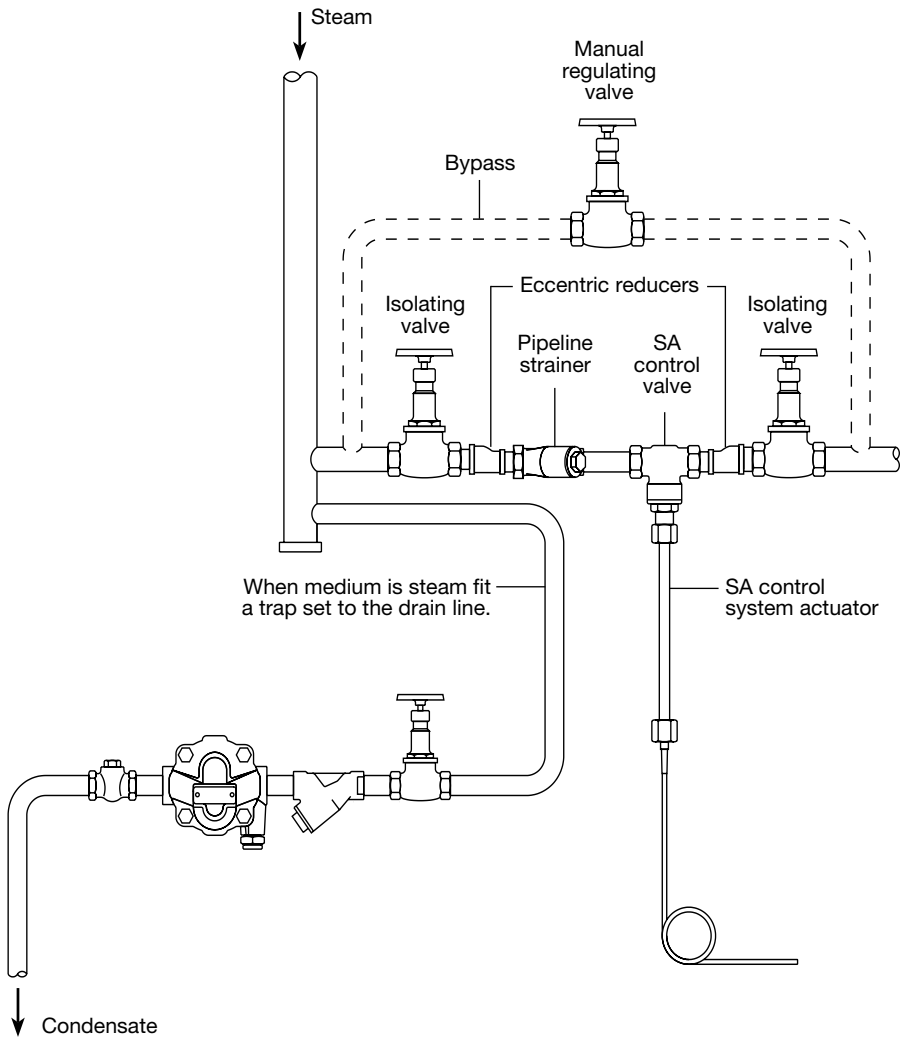

Fig. 1 Typical installation showing recommended bypass

3.5 Permanent bleed

BMRA and BXRA valves are normally closed. When used as a cooling control it may be necessary to create a permanent flow over the sensor. In this case this can be achieved by installing a small bore bypass around the valve as shown in Figure 2. A 6 mm line will usually be adequate with the manual valve about one turn open.

SBRA (Figure 3) and KX (DN15 - 25) (Figure 4) valves are available with or without bleed. When used as a cooling control with the sensor fitted in the cooling liquid line a valve having a bleed would be required. This bleed hole is now fixed. In other cases, a non bleed valve should be installed.

With KX and KY valves (DN32 - 50) (Figure 5) again models are available with or without bleed. Valves with a bleed arrangement have a 3 mm hole between the inlet and outlet. This permanent bleed arrangement can be sealed by tapping the hole and sealing it off with a 4BA or M4 screw before the valve is installed.

Fig. 2
Typical bypass
arrangement for
the BMRA and
BXRA valves

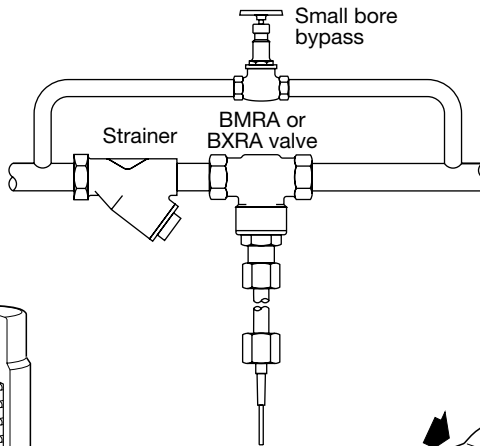

Optional
extra
bleed

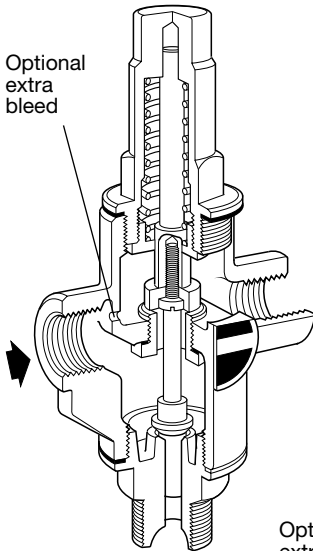
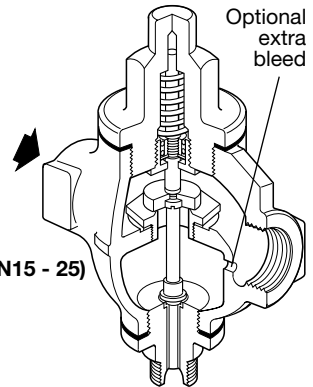

Fig. 3 SBRA

Fig. 4
KX (DN15 - 25)



Optional
extra
bleed

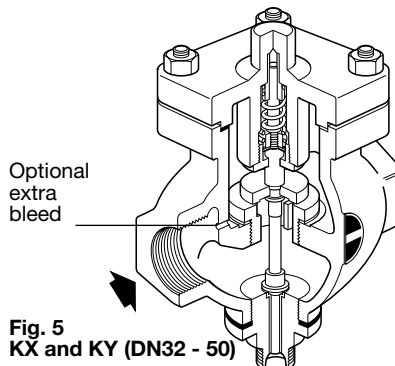

Fig. 5
KX and KY (DN32 - 50)

4. Maintenance

Note: Before actioning any maintenance programme observe the 'Safety information' in Section 1.

Warning

The metal foil sheet used to reinforce gaskets is very thin and sharp. Care should be taken when handling to avoid the possibility of cuts or lacerations to fingers or hands.

4.1 Routine maintenance procedures

24 hours operation

After 24 hours service check pipework connections and flange bolts for tightness.

Annually

The valve should be inspected for wear and tear replacing any worn or damaged parts such as valve plug and stem, valve seat.

4.2 General maintenance information:

- The valve faces must be kept clean.
- The strainer should be cleaned at regular intervals to ensure that the flow to the valve is clean and unrestricted.
- If at any time it is necessary to take the valve out of the line for servicing then the appropriate safety precautions need to be adhered to (see Section 1).
- The available spares and fitting instructions are detailed on the appropriate Technical Information Sheet (see Section 2).

4.3 KB and KC valves (refer to Figure 6)

With the bellows assembly it is essential that the central passage 'X' through the valve push rod and the ports 'Y' are kept clear. To facilitate cleaning (should this become necessary) the end of the passage is blanked by a 4 mm 'Unbrako' set screw 'Z' which can be removed to enable a piece of wire to be passed through the passage and ports.

It is important that the set screw 'Z' is replaced before the valve is put back into service.

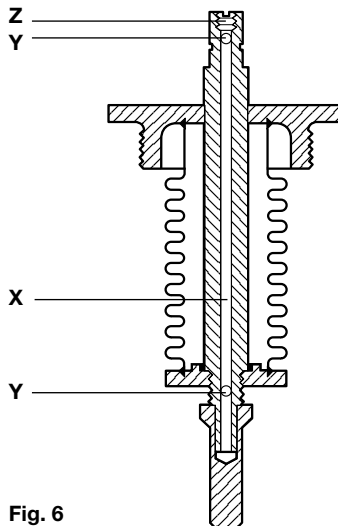

Fig. 6

4.4 SBRA valve with fusible device (refer to Figures 7 and 8)

Replacing or resetting the fuse:

- Isolate the valve and unscrew the bonnet (see Figure 7).
- Unscrew the retaining nut and withdraw the valve, valve stem, fuse and spring assembly.
- The fuse may now be unscrewed from the valve stem and the new one fitted (see Figure 8). Alternatively the existing fuse may be reset after dismantling as above, by immersing it in hot water at a temperature above its fusing point 80°C (176°F) on the standard fuse. When the fuse solder head reaches a fluid state the two cylinders can be pushed together until the ends are flush. Allow to cool and refit.

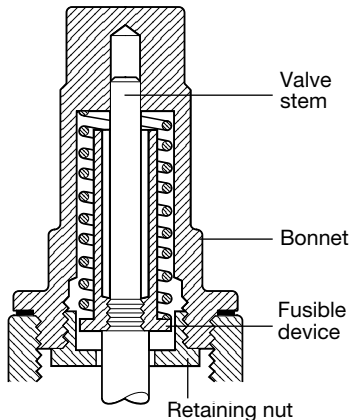

Fig. 7

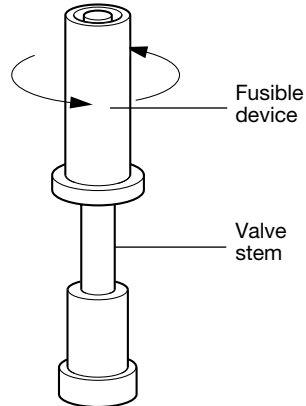

Fig. 8

4.5 KA61, KA63 and KC63 valves (refer to Figure 9)

Firstly remove the control system sensor from the plant and allow to cool.

SA controls:

- Disconnect the actuator from the valve.
- Before attempting to carry out any repairs, make sure that the valve is fully isolated.
- It is important to always renew the complete assembly as listed above and to make sure that all of the joint faces are clean.

How to replace the valve seat assembly

Remove the bonnet assembly and unscrew the head/bellows assembly **X** from the bonnet.

KC63:

- The complete head/bellows assembly can now be withdrawn and a new assembly fitted.

KA63 and KC63:

- Remove the circlip **C**, washer **U**, head **A** and seal **B** and refit the parts in reverse order ensuring that the circlip is correctly located in the groove.

KA61:

- The complete head **A** can now be withdrawn and a new assembly fitted.
- Unscrew the valve seat **D** and replace with a new seat ring and seat gasket.
- Lightly coat all the gaskets with a suitable jointing compound before fitting.
- Refit the bonnet assembly using new gaskets, taking care to tighten the bonnet nuts evenly.

How to replace the bellows assembly

Remove the bonnet assembly and the bellows assembly by unscrewing the bellows assembly guide **X**. Remove the circlip **C**, washer **U**, head **A** and seal **B** and refit to the new bellows assembly in reverse order.

Refit the new bellows assembly and back seal plunger to the valve bonnet. Refit the bonnet assembly using the new gaskets taking care to the tighten bonnet nuts evenly to the recommended torque (see Table 1).

KA63 and KC63

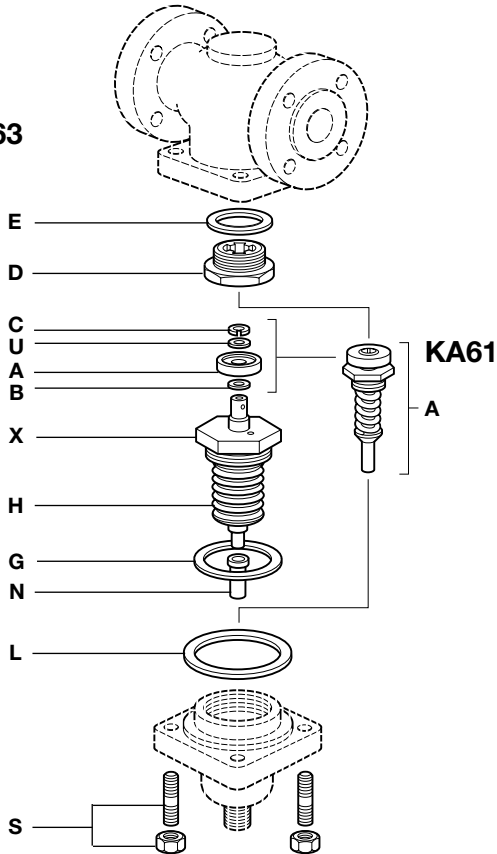

Fig. 9

Table 1 Recommended tightening torques (N m)

Size	KA61 and KA63		KC63		
	Seat	Bonnet nuts	Seat	Bonnet nuts	Bellows assembly
DN15	50	18	-	-	-
DN20	110	23	-	-	-
DN25	160	28	-	-	-
DN32	100	43	100	40	180
DN40	150	43	150	40	180
DN50	180	63	165	60	200

5. Spare parts

Refer to 'Spare parts' on the relevant Technical Information Sheet as listed in Section 2.