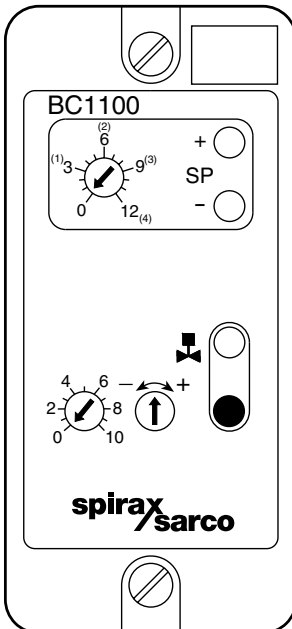

BC1100
Controller**Installation and Maintenance Instructions**

1. *General safety information*
2. *General product information*
3. *Installation*
4. *Setting up the controller*
5. *Wiring diagram*
6. *Commissioning*
7. *Maintenance*
8. *Fault finding*

1. General safety information

Your attention is drawn to Safety Information Sheet IM-GCM-10 as well as to any National or local regulations.

Safe operation of the product depends on it being properly installed, commissioned and maintained by a qualified person in compliance with the operating instructions.

It is essential to comply with general installation and safety instructions for pipeline and plant construction, as well as to make proper use of tools and safety equipment.

The product is designed and constructed to withstand the forces encountered during normal use. Use of the product for any other purpose, or failure to install the product in accordance with these Installation and Maintenance Instructions, could cause damage to the product, will invalidate the CE marking, and may cause injury or fatality to personnel.

Warning

Isolate the mains supply before unplugging the controller since hazardous voltages will be exposed on the controller base. This product complies with the requirements of Electromagnetic Compatibility Directive 89/336/EEC by meeting the standards of:

- BS EN 50081-1 (Emissions) and
- BS EN 61000-6-2 (Immunity).

The following conditions should be avoided as they may create interference above the limits specified in BS EN 61000-6-2 if:

- The product or its wiring is located near a radio transmitter.
- Excessive electrical noise occurs on the mains supply. Power line protectors (ac) should be installed if mains supply noise is likely. Protectors can combine filtering, suppression, surge and spike arrestors.
- Cellular telephones and mobile radios may cause interference if used within approximately 1 metre (39") of the product or its wiring. The actual separation distance necessary will vary according to the surroundings of the installation and the power of the transmitter.

If this product is not used in the manner specified by this IMI, then the protection provided may be impaired.

— 2. General product information —

2.1 General description

The Spirax Sarco BC1100 controller is part of an integrated range of boiler house equipment, designed for DIN rail or chassis mounting. The controller is used in conjunction with a Spirax Sarco conductivity sensor and blowdown valve to monitor and control the concentration of total dissolved solids (TDS) in steam boilers.

The BC1100 has a set point potentiometer, and coarse and fine calibration potentiometers on the front panel.

A green LED indicates that the controller is operating, and that the conductivity is below the set point.

An amber LED indicates that the conductivity is above the set point.

A purge button is provided to open the blowdown valve manually, and a second amber LED indicates that the blowdown valve is open.

Voltage, range, and output parameters are set on installation using internal switches. The controller can be wired to give a purge every half hour of boiler firing, every half hour (whether the boiler has fired or not), or, for applications where the sensor is mounted in the boiler shell, to give no purge. The duration of the purge can be set using internal switches. (See Section 4, 'Setting up the controller').

A pulsed or continuous output to the blowdown valve may be selected. The pulsed output, (10 seconds open, 20 seconds closed), is suitable for smaller boilers, where continuous valve operation may cause the boiler water level to fall excessively.

As well as the relay output, the BC1100 has a 4 - 20 mA (or 0 - 20 mA) output.

The output represents the controller range and may be used for remote TDS display, as a chart recorder input, or as an input to a computer monitoring system. Note that the -ve terminal is earthed. If required, this output signal can be held low (4 or 0 mA) when the blowdown valve is closed. The switch-selectable feature is useful for in-line sensor installations to prevent a slowly falling signal being transmitted when the blowdown valve is closed and the blowdown line is cooling.

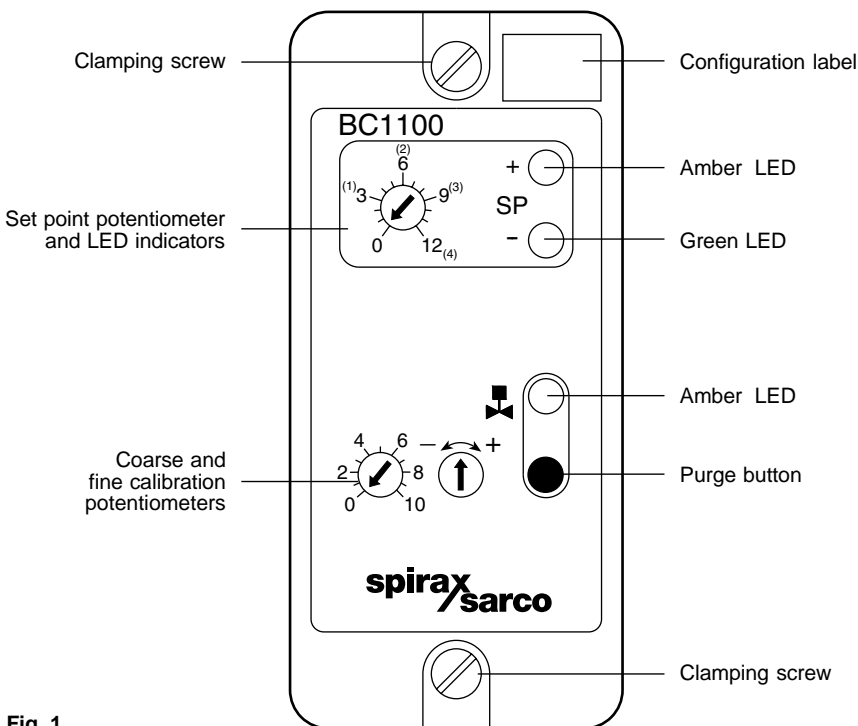

Fig. 1

The controller opens the blowdown valve periodically to purge the system and allow a sample of boiler water to pass the sensor. The electrical conductivity of this sample is compared with the set point selected on the controller front panel.

If the conductivity is lower than the set point, the controller allows the blowdown valve to close. If the conductivity is higher than the set point, the valve remains open, allowing the contaminated boiler water to be replaced by clean make-up water.

The valve closes when the conductivity of the boiler water drops below the set point. Accuracy for blowdown duties is $\pm 10\%$.

Factors reducing the accuracy of control include large variations in boiler pressure and wide pH swings. Whenever the TDS is measured by taking a manual sample of boiler water, the result should be compared with the controller set point by pressing the purge button, then turning the set point (SP) potentiometer until the LEDs change from green to amber. The TDS can then be read off the set point scale.

If the boiler is operating normally yet the readings differ significantly the controller may simply be recalibrated to the new TDS reading. If it is found that the calibration has drifted to more than twice its original setting, then the sensor may need cleaning.

If scale is forming on the sensor tip it is a certain warning that scale will also be forming on the boiler tubes. Boiler water treatment must be investigated.

2.2 Technical data

Maximum ambient temperature	55°C	(131°F)
Minimum ambient temperature	0°C	(32°F)
Temperature compensation range	100 - 239°C	(212 - 462°F)
Pollution degree	2	
Overvoltage category	II	
Indoor use only		
Altitude up to	2 000 m	(6 561.5 ft)
Humidity	Maximum relative humidity 80% for temperatures up to 31°C (87.8°F) decreasing linearly to 50% relative humidity at 40°C (104°F).	
Protection rating	IP40	
Maximum cable length (controller to probe)	See Table 2 in Section 5	
Mains supply voltage	230 V setting	198 V - 264 V
	115 V setting	99 V - 132 V
Frequency	50 - 60 Hz	
Fuse type	20 mm cartridge, 100 mA anti-surge (T). For the UL version, replacement fuses must be UL recognised to maintain the integrity of the approval.	
Maximum power consumption	6 VA	
Maximum 0/4 - 20 mA output load	500 Ω	
Minimum conductivity setting	40 μS/cm or 40 ppm	
Terminal torque rating	1 N m	(9 lbf ft)

3. Installation

3.1 Installation

WARNING: Isolate the mains supply before unplugging the controller since hazardous voltages will be exposed on the controller base.

To unplug the controller from its base, undo the two retaining screws and pull the controller straight forwards. Rocking the controller in the vertical plane will ease removal.

The controller must be installed in a suitable industrial control panel or fireproof enclosure to provide environmental protection (pollution degree 2). Spirax Sarco can provide suitable plastic or metal enclosures (for the standard controller only).

The controller may be mounted on a 'top hat' DIN rail using the clip provided or the clip can be removed and the controller base screwed directly to a chassis plate.

Caution: Allow 15 mm spacing between multiple units for air circulation.

The controller is for installation category II (Overvoltage category) and must be installed in accordance with IEC 60364 or equivalent. The controller and all connected circuits must have a common isolation system which meets the relevant requirements of IEC 60947-1 and IEC 60947-3 or equivalent. This must be positioned close to the controller and clearly identified as the disconnect device.

A quick blow 3 amp external fuse must be fitted in all phases of the controller relay supply.

A quick blow 1 amp external fuse must be fitted if the burner input is connected.

The relay is rated at 250 V and must be on the same phase as the controller supply.

Cabling should be installed in accordance with BS 6739 - Instrumentation in Process Control Systems: Installation design and practice or local equivalent.

Table 1 - Relay rating table:

Version	Relay load type	Rating
Standard	Resistive at 250 Vac	3 A
	Inductive at 250 Vac	1 A
	Lamp or resistive at 240 Vac	3 A
	Tungsten filament at 240 Vac	1 A
UL listed	AC motor at 240 Vac	¼ HP (2.9 A)
	AC motor at 120 Vac	¼ ₁₀ HP (3 A)
	Pilot duty (control circuits/coils)	C300 (2.5 A)

For the US and Canadian markets the controller must be wired in accordance with the National and Local Electrical Code (NEC) or Canadian Electrical Code (CEC).

Note:- The wiring diagrams (Section 5) show the relay in the power off position.

Screened high temperature, 2/4 core, 1 mm² (18 - 16 AWG) copper cable is required for the probe wiring. Use cable with a suitable temperature rating for the installation. Pirelli FP200 or Delta Crompton Firetuf OHLS are suitable cables for the standard version.

The controller terminals are suitable for two 1.5 mm² or 16 AWG cables (max).

The same cable may be used for the mains wiring. For maximum probe cable lengths see Table 2 in Section 5, 'Wiring diagram'. Connect the screens as shown in the wiring diagram.

3.2 Selecting a purge duration

It is important to select a purge duration which allows a 'fresh', hot sample of boiler water to reach the sensor whilst not wasting heat by setting too long a time. It is for this reason that we recommend the in-line sensor is installed as close to the boiler as possible. Variables which affect the required blowdown time are:

- Length and diameter of the blowdown line.
- Type and capacity of the blowdown valve.

Caution: With some small boilers, excessive purge time may lower the water level significantly, and may even trigger a low water alarm.

As individual boiler plant differs considerably, we recommend that the optimum time is found by experimentation. Starting with a cold blowdown line, press and hold the purge button down, and check the time it takes for the set point (or the 4 - 20 mA signal) to stabilise.

If the product is not used in the manner specified in this IMI, then the protection provided may be impaired.

4. Setting up the controller

4.1 Setting up the controller

The controller is supplied set up as follows:

- 230 V mains supply.
- 1200 - 12 000 $\mu\text{S}/\text{cm}$.
- 10 second purge.
- Valve not pulsed.
- 4 - 20 mA output, held to 4 mA when the valve is closed.

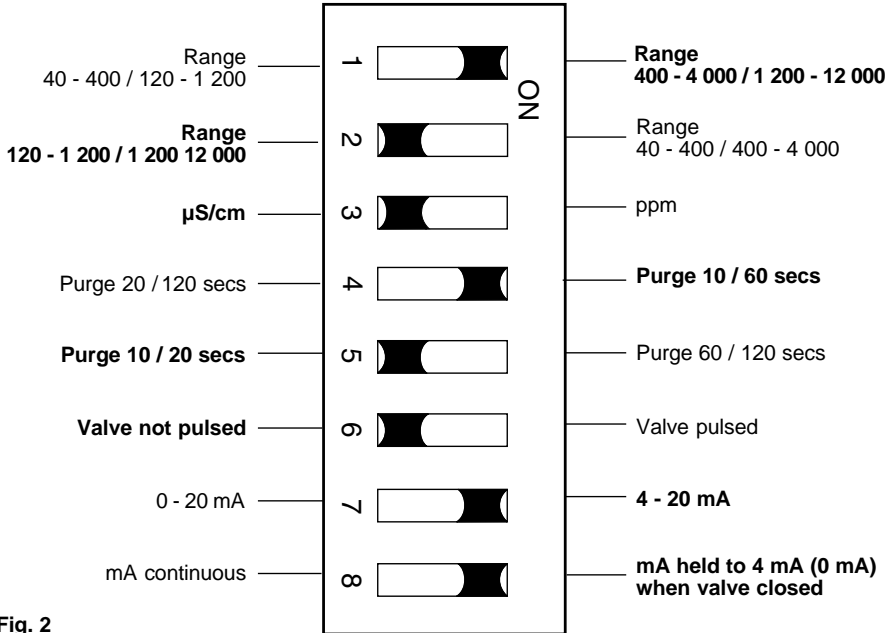
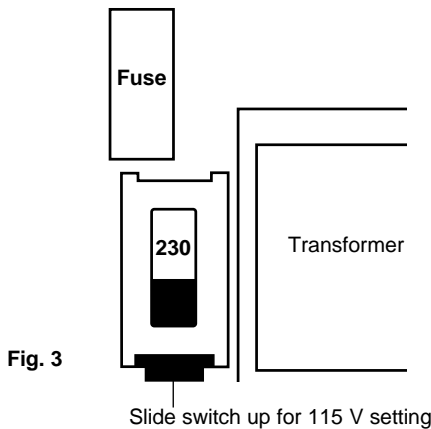

Fig. 2

4.2 To change the mains supply voltage:

- Loosen the two cover clamping screws.
- Unplug the controller from its base.
- Remove the rear cover panel.
- Slide out the printed circuit board assembly.
- Move the voltage selector switch to the 115 V setting. See Figure 3.
- Replace the printed circuit board assembly.
- Replace the rear cover panel.
- Plug the controller into its base.
- Tighten the cover screws.



4.3 To change the controller range:

Remove the printed circuit board as described in Section 4.2. Select the required range in $\mu\text{S}/\text{cm}$ or ppm by setting switches 1, 2 and 3 as shown in Figure 2.

4.4 To change other settings:

- Remove the printed circuit board.
- Select the required functions by setting switches 4 to 8, as shown in Figure 2.

Note: Switch 6 setting 'valve pulsed' can only be used with a quick-acting blowdown valve, and so is not recommended for the BCV30.

5. Wiring diagram

For 'Wiring notes', see page 10.

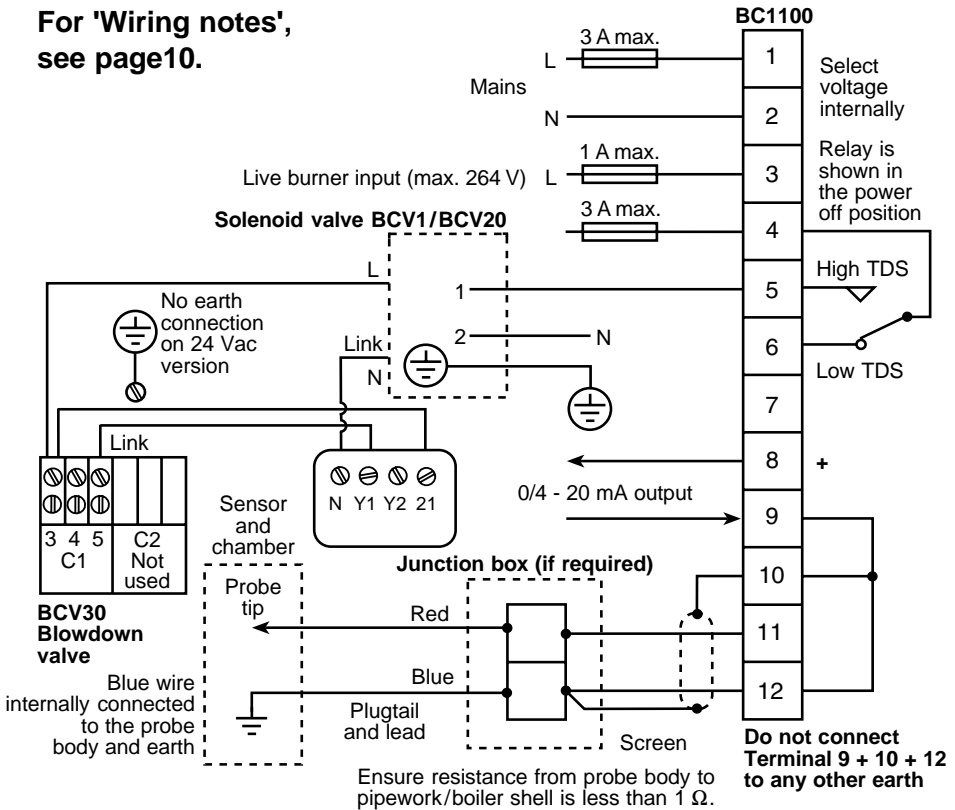

Fig. 4 Wiring diagram - standard version

5.1 Screen connection

An earth current loop is created if a wire or screen is connected between two earth points, which are at different potential (voltage). If the instructions are followed correctly, then the probe and controller screen will only be connected to earth at one end.

Note: The probe earth terminal is a functional earth rather than a protective earth.

A protective earth provides protection from electric shock under a single fault condition. This product has double insulation and therefore does not require a protective earth.

A functional earth is used in order for the product to operate. In this application, the earth (pipework/tank/boiler shell) is used as the common of the probe. It also provides sink/drain for any electrical interference.

Ensure that the screen is connected to the earth terminal of the probe and to the common terminal of the controller.

Ensure the common terminal of the controller is not internally earthed. (All Spirax Sarco boiler controls are internally isolated from earth).

The common terminal of the controller must only be earthed via the probe.

CAUTION:

Do not connect the common terminal to an earth local to the controller. To do so may induce an earth current loop, which may reduce the performance or damage the product.

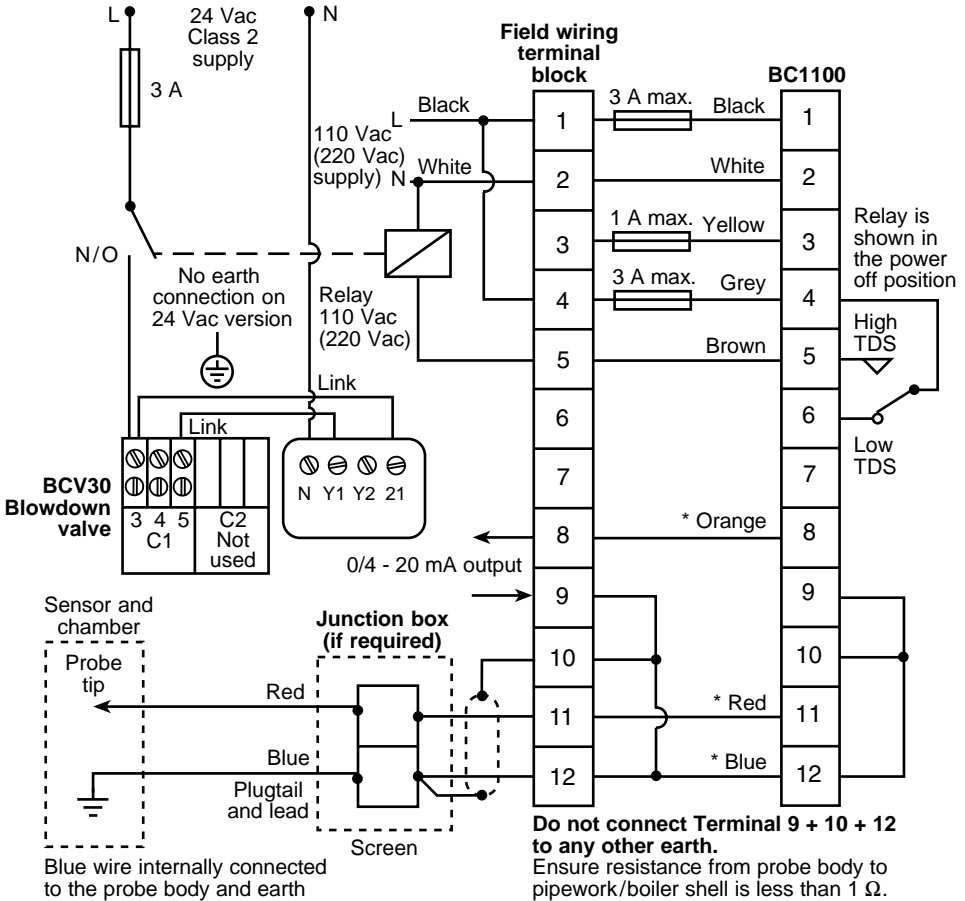

* Wiring must be run directly between terminal block and controller, and should not be close to other control wiring.

Ensure correct isolation is provided between low voltage mains supply and Class 2 supply to the actuator.

Fig. 5 Wiring diagram - UL version used with a 24 Vac BCV30

Table 2 - Maximum cable lengths

Maximum water conductivity at 25°C	Maximum cable resistance	Maximum cable length 2 core cable (single cores)	Maximum cable length 4 core cable (2 cores in parallel)
12 000 µS/cm	0.11 Ω	6.25 m (20.5 ft)	12.5 m (41.0 ft)
8 000 µS/cm	0.17 Ω	9.50 m (31.0 ft)	19.0 m (62.3 ft)
4 000 µS/cm	0.35 Ω	19.00 m (62.3 ft)	38.0 m (124.6 ft)
1 500 µS/cm	0.90 Ω	50.00 m (164.0 ft)	100.0 m (328.0 ft)
<1 200 µS/cm	-	100.00 m (328.0 ft)	100.0 m (328.0 ft)

5.2 Wiring notes

Maximum cable length from the controller to the sensor varies according to the controller conductivity range setting.

If multiple cables or alternative larger cable is used, any cable length up to 100 m (328 ft) is permissible as long as the maximum cable resistance does not exceed the values shown in Table 2, page 9. For conductivity ranges below 1 200 $\mu\text{S}/\text{cm}$, the recommended cable only should be used, with no more than two cores in parallel.

Caution: Mains supplies must be on the same phase (single phase, max 264 V).

To wire the controller to purge every half hour of boiler firing, connect terminal 3 to the burner ON switch (live when burner on).

To wire the controller to purge every half hour, whether the burner has fired or not, link controller terminals 1 and 3. The 1 A fuse in Figure 4 is then not required.

If the conductivity sensor is mounted in the boiler shell, no purge is required, so leave terminal 3 unwired. The purge switches, (4, 5, and 6), shown on page 6, may be left in any position.

6. Commissioning

Note: Calibration must only be carried out when the blowdown valve is open.

Press and hold down the purge button to open the valve.

1. Measure the TDS or conductivity of the boiler water. The Spirax Sarco MS1 conductivity meter is a suitable instrument for this purpose.
2. Turn the 'SP' (set point) potentiometer to match the measured boiler water conductivity.
3. With the boiler at operating temperature, press and hold the purge button until the blowdown line and valve reach boiler temperature.
4. Without releasing the purge button, turn the coarse (left hand) then the fine (right hand) CAL potentiometers until the '-' green LED just goes off and the '+' amber LED just comes on.
5. Release the purge button.
6. Turn the set point potentiometer to the required conductivity level, as recommended by the boiler manufacturer.
This will be the conductivity level at which the blowdown valve will open.

7. Maintenance

No special maintenance of the controller is necessary. The following maintenance, however, is recommended for the system:-

Weekly

- Take a sample of the boiler water through a sample cooler, measure its TDS, or conductivity, and check the controller calibration with the boiler at normal operating pressure.
- Check that the blowdown valve shuts off when the green LED is lit or when the power is removed.
- Operate any stop valves to ensure they shut off and remain free.

Every six months

- Isolate the system (or with the boiler empty) and remove the conductivity sensor.
- Clean the tip with fine abrasive paper and the insulation with a bristle brush or a cloth.
- Examine the blowdown control valve/solenoid valve, stop valve and other fittings.
- Clean and replace any parts necessary.

Available spares

Spare fuses	Stock no. 4033380	Set of 3
-------------	-------------------	----------

8. Fault finding

Problems experienced during commissioning are often found to be due to incorrect wiring, so we recommend that a complete check is carried out. Check the mains supply voltage is within the specified limits and that the controller has been set for the correct functions. The controller may be checked for correct operation by substituting a resistor for the conductivity sensor, or by using the Spirax Sarco Probe Simulator. This will allow the various controller functions to be tested.

- Disconnect the conductivity sensor.
- Set switch 3 to ' $\mu\text{S}/\text{cm}$ '.
- Set the left hand CAL potentiometer to '3' (± 0.5), and turn the right hand one fully clockwise.
- Select a resistor from the Table below and connect it between controller terminals 11 and 12.
- Adjustment of the set point potentiometer should then cause the green and amber LED's to change state at approximately mid-scale.

Range setting ($\mu\text{S}/\text{cm}$)	Resistor value
40 - 400	680 Ω
120 - 1 200	220 Ω
400 - 4 000	68 Ω
1 200 - 12 000	22 Ω

