



**AEL7T**

**EN14597 Compliant  
Electric Linear Actuators**  
Installation and Maintenance Instructions

---

---

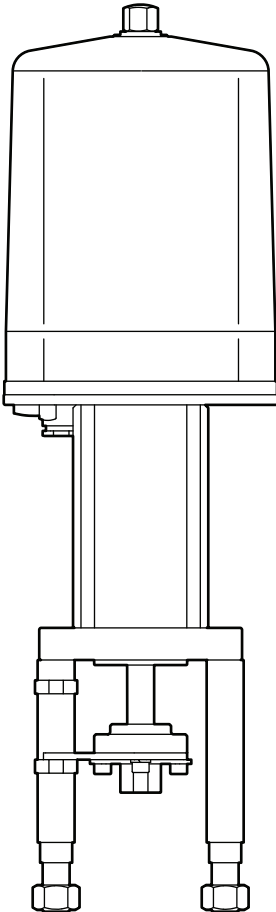

1. Safety information
2. General product information
3. Electrical connection
4. Installation
5. Actuator Accessories
6. Commissioning
7. Maintenance
8. Declaration of Conformity



# Contents

<b>1. Safety information</b>	<b>5</b>
1.1 Wiring notes	
1.2 Safety requirements and electromagnetic compatibility	
1.3 Intended use	
1.4 Access	<b>6</b>
1.5 Lighting	
1.6 Hazardous liquids or gases in the pipeline	
1.7 Hazardous environment around the product	
1.8 The system	
1.9 Pressure systems	
1.10 Responsibilities of the operator and operating (including maintenance) personnel	<b>7</b>
1.11 Temperature	
1.12 Tools and consumables	
1.13 Protective clothing	
1.14 Permits to work	
1.15 Handling	
1.16 Safe lifting practice	<b>8</b>
1.17 Residual hazards	
1.18 Disposal	
1.19 Responsibilities of the operator and operating (including maintenance) personnel	<b>9</b>
1.20 Qualified Personnel	
<b>2. General product information</b>	<b>10</b>
2.1 Description	
2.2 Identification of products in the AEL7T range	<b>11</b>
2.3 Operating principle	<b>12</b>
2.4 EN14597 Compliance	<b>13</b>
<b>3. Installation</b>	<b>14</b>
3.1 Electrical Connection Safety Information	
3.2 Removing the Actuator Cover	
3.3 Making the Electrical Connection	<b>15</b>
3.4 Electrical Connection	<b>16</b>

<b>4. Installation</b>	<b>18</b>
4.1 Location	
4.2 Operational Considerations – End Position and Stroke Settings	
4.3 Manual Override	<b>19</b>
4.4 Coupling the actuator to a Valve	<b>20</b>
4.5 Setting the end position	<b>23</b>
<b>5. Actuator Accessories</b>	<b>27</b>
5.1 Actuator Accessory Safety Information	
5.2 Auxiliary Travel Switches	<b>28</b>
5.3 Potentiometer	<b>29</b>
5.4 Positioner Card	<b>30</b>
<b>6. Commissioning</b>	<b>31</b>
6.1 Commissioning Safety Information	
6.2 Adjustment of Auxiliary Travel Switch	<b>32</b>
6.3 Commissioning of Potentiometer	
6.4 Commissioning of Positioner Card	<b>33</b>
6.5 AUTOTUNE – Quick Set-Up	<b>36</b>
<b>7. Maintenance</b>	<b>37</b>
7.1 Maintenance Safety Information	
7.2 General Maintenance of Actuator	
7.3 Warranty, Repair and Spare Parts	<b>38</b>
7.4 Removing the Actuator from the Valve	<b>39</b>
7.5 Problem Solving	<b>40</b>
<b>8. Declaration of Conformity</b>	<b>41</b>

# 1. Safety information

Safe operation of this product can only be guaranteed if it is properly installed, commissioned, used and maintained by qualified personnel (see Section 1.20) in compliance with the operating instructions. General installation and safety instructions for pipeline and plant construction, as well as the proper use of tools and safety equipment must also be complied with.

See separate Installation and Maintenance Instructions for the control valve.

If the actuator is handled improperly or not used as specified, the resultant may:

	<ul style="list-style-type: none"><li>- Cause danger of the life and limb of the third party</li><li>- Damage the actuator and other assets belonging to the owner</li><li>- Hinder the performance of the actuator</li></ul>
---	---

## 1.1 Wiring notes

Every effort has been made during the design of the actuator to ensure the safety of the user, but

the following precautions must be followed:

- i) Maintenance personnel must be suitably qualified in working with equipment containing hazardous live voltages.
- ii) Ensure correct installation. Safety may be compromised if the installation of the product is not carried out as specified in this manual.
- iii) Isolate the actuator from the mains supply before opening the unit.
- iv) The actuator is designed as an installation category II product, and is reliant on the building installation for overcurrent protection and primary isolation.
- v) Wiring should be carried out in accordance with IEC 60364 or equivalent.
- vi) Fuses should not be fitted in the protective earth conductor. The integrity of the installation protective earth system must not be compromised by the disconnection or removal of other equipment.
- vii) A disconnecting device (switch or circuit breaker) must be included in the building installation.

This must be in close proximity to the equipment and within easy reach of the operator.

- There must be a 3 mm contact separation in all poles.
  - It must be marked as the disconnecting device for the actuator.
  - It must not interrupt the protective earth conductor.
  - It must not be incorporated into a mains supply cord.
  - The requirements for the disconnecting device are specified in IEC 60947-1 and IEC 60947-3 or equivalent.
- viii) The actuator must not be located in such a way that the disconnecting device is made difficult to operate.

## 1.2 Safety requirements and electromagnetic compatibility

This product is  marked.

It complies with the requirements of 73/23/EEC as amended by 93/68/EEC on the harmonisation of the law of Member States relating to electrical equipment designed for use within certain voltage limits (LVD), by meeting the standard for safety of electrical equipment for measurement control and laboratory use. This product complies with the requirement of 89/336/EEC as amended by 92/31/EEC and 93/68/EEC on the approximation of laws of the Member States relating to Electromagnetic Compatibility, by meeting the generic standard of emissions for an industrial environment and the generic standard of immunity for an industrial environment. The product may be exposed to interference above the limits of industrial immunity if:

- i) The product or its wiring is located near to a radio transmitter.
- ii) Excessive electrical noise occurs on the mains supply.
- iii) Cellular telephones and mobile radios may cause interference if used within approximately one metre of the product or its wiring. The actual separation necessary will vary according to the power of the transmitter.
- iv) Power line protectors (ac) should be installed if mains supply noise is likely.
- v) Protectors can combine filtering, suppression, surge and spike arrestors.

For a copy of the declaration of conformity please refer to page 58.

## 1.3 Intended use

The AEL7 Series actuator must only be used to modulate Spirax Sarco and Gestra valves (including Hiter). The actuator must not be used for any other purpose.

Referring to the Installation and Maintenance Instructions, name-plate and Technical Information Sheet, check that the product is suitable for the intended use/application.

- i) Check products suitability to ensure product is suitable in relation to the thrust required to modulate and close the valve. (Refer to TI-P713-02)
- ii) Check that actuator is suitable for the operating environment and insure adequate protection is implemented when required
- iii) Determine the correct installation situation.
- iv) Spirax Sarco products are not intended to withstand external stresses that may be induced by any system to which they are fitted. It is the responsibility of the installer to consider these stresses and take adequate precautions to minimise them.

## 1.4 Access

Ensure safe access and if necessary a safe working platform (suitably guarded) before attempting to work on the product. Arrange suitable lifting gear if required.

## 1.5 Lighting

Ensure adequate lighting, particularly where detailed or intricate work is required.

## 1.6 Hazardous liquids or gases in the pipeline

Consider what is in the pipeline or what may have been in the pipeline at some previous time. Consider: flammable materials, substances hazardous to health, extremes of temperature.

## 1.7 Hazardous environment around the product

Consider: explosion risk areas, lack of oxygen (e.g. tanks, pits), dangerous gases, extremes of temperature, hot surfaces, fire hazard (e.g. during welding), excessive noise, moving machinery.

## 1.8 The system

Consider the effect on the complete system of the work proposed. Will any proposed action (e.g. closing isolation valves, electrical isolation) put any other part of the system or any personnel at risk? Dangers might include isolation of vents or protective devices or the rendering ineffective of controls or alarms. Ensure isolation valves are turned on and off in a gradual way to avoid system shocks.

## 1.9 Pressure systems

Ensure that any pressure is isolated and safely vented to atmospheric pressure. Consider double isolation (double block and bleed) and the locking or labelling of closed valves. Do not assume that the system has depressurised even when the pressure gauge indicates zero.

## 1.10 Responsibilities of the operator and operating (including maintenance) personnel

The operator is responsible for ensuring that safe systems of operation and practice are implemented and maintained. Only competent persons must be allowed to be able to operate and maintain these devices, and these persons must be familiar with, and comply with the applicable health and safety standards or guidelines.

The installation and maintenance instructions should form part of the standard operating procedures for maintenance and must therefore be kept in an accessible location and in a legible condition.

Product identification and safety related labels must also be kept in a clean and legible condition. Identification and safety labels must be replaced if they become damaged or obscured in operation.

## 1.11 Temperature

Allow time for temperature to normalise after isolation to avoid danger of burns.

The actuator must not be insulated. When coupled to a valve operating on high temperature media, if there is a risk of burning through handling (intentional or accidental), it is recommended that suitable methods of prevention are implemented e.g. machine or a visual warning.

## 1.12 Tools and consumables

Before starting work ensure that you have suitable tools and/or consumables available. Use only genuine Spirax Sarco replacement parts.

## 1.13 Protective clothing

Consider whether you and/or others in the vicinity require any protective clothing to protect against the hazards of, for example, chemicals, high/low temperature, radiation, noise, falling objects, and dangers to eyes and face.

## 1.14 Permits to work

All work must be carried out or be supervised by a suitably competent person. Installation and operating personnel should be trained in the correct use of the product according to the Installation and Maintenance Instructions. Where a formal 'permit to work' system is in force it must be complied with. Where there is no such system, it is recommended that a responsible person should know what work is going on and, where necessary, arrange to have an assistant whose primary responsibility is safety. Post 'warning notices' if necessary.

## 1.15 Handling

Manual handling of large and/or heavy products may present a risk of injury. Lifting, pushing, pulling, carrying or supporting a load by bodily force can cause injury particularly to the back. You are advised to assess the risks taking into account the task, the individual, the load and the working environment and use the appropriate handling method depending on the circumstances of the work being done.

## 1.16 Safe lifting practice

Never use the actuator to lift a valve. It is recommended to lift the complete valve assembly using the correct equipment(s) and techniques so as not to cause damage or injury. Valves should be supported under the inlet and outlet connections, not the actuator (including hand wheel or accessories), and careful attention should be made to prevent the valve from rotating during the lift sequence. When installed, neither the actuator, valve or its accessories should be used as a hand hold or step for access to other parts of the plant.

## 1.17 Residual hazards

In normal use the external surface of the product may be very hot. If used at the maximum permitted operating conditions the surface temperature of some products may exceed temperatures of 90 °C (194 °F).

## 1.18 Disposal

Unless otherwise stated in the Installation and Maintenance Instructions, this product is recyclable and no ecological hazard is anticipated with its disposal providing due care is taken.

## Regulation (EC) No 1907/2006 - Registration, Evaluation, Authorisation and Restriction of Chemicals (REACH)

Should any substances of very high concern be found within a product, details of the location will be identified within the Technical Information Sheet.

Further information about product compliance is available at [www.spiraxsarco.com/product-compliance](http://www.spiraxsarco.com/product-compliance)



## 1.19 Responsibilities of the operator and operating (including maintenance) personnel

The operator is responsible for ensuring that safe systems of operation and practice are implemented and maintained. Only competent persons must be allowed to be able to operate and maintain these devices, and these persons must be familiar with, and comply with the applicable health and safety standards or guidelines.

The installation and maintenance instructions should form part of the standard operating procedures for maintenance and must therefore be kept in an accessible location and in a legible condition. Product identification and safety related labels must also be kept in a clean and legible condition. Identification and safety labels must be replaced if they become damaged or obscured in operation.

## 1.20 Qualified Personnel

The operator is responsible for ensuring that safe systems of operation and practice are implemented and maintained. Only qualified personnel must be allowed to make the electrical power connections to the AEL7 Series actuator, and these personnel must be familiar with, and comply with the applicable health and safety standards or guidelines. Failure to do so could result in death, severe physical injuries or material damages to the actuator, valve and associated equipment.

Suitably qualified personnel are those who are familiar with the set-up, installation, commissioning and operation of the AEL7T and associated valves. Personnel should be suitably qualified through their activity:

- Training and authority to switch on and off power circuits
- Training to the relevant safe standard of electrical practice and the knowledge to correctly earth and mark electrical connections
- Training in first aid and the use of associated safety equipment

Copyright © Spirax-Sarco Limited 2022

### All rights reserved

Spirax-Sarco Limited grants the legal user of this product (or device) the right to use the Work(s) solely within the scope of the legitimate operation of the product (or device). No other right is granted under this licence. In particular and without prejudice to the generality of the foregoing, the Work(s) may not be used, sold, licensed, transferred, copied or reproduced in whole or in part or in any manner or form other than as expressly granted here without the prior written consent of Spirax-Sarco Limited.

## 2. General product information

### 2.1 Description

AEL7T series electric linear actuators are only suitable for the use on Spirax Sarco, Gestra and Hiter Valves. Refer to T1-P713-02 for product compatibility and linkage requirements. The AEL7T Series actuators must not be used for any other purpose. Actuators will normally be supplied fitted to the control valve. When supplied separately, ensure the actuator selected is capable of providing the force necessary to close the two-port or three-port control valve against the expected differential pressure. See the appropriate product specific Technical Information Sheet for full details of the control valve.

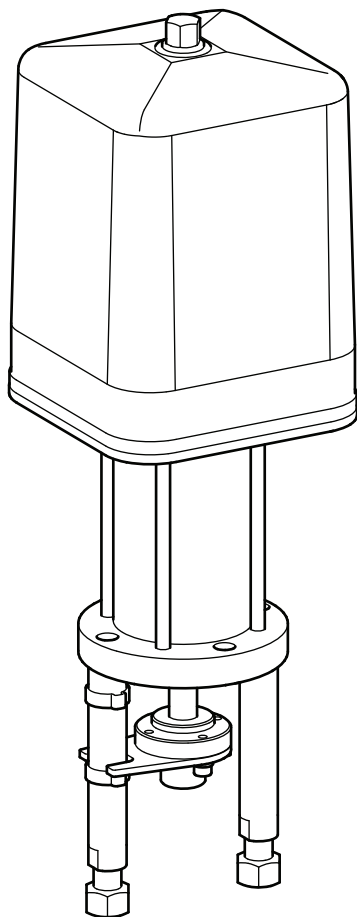

Fig. 1

## 2.2 Identification of products in the AEL7T range

<b>Actuator</b>	<b>A</b>	-	
<b>Type</b>	<b>E</b>	Electric	
<b>Action</b>	<b>L</b>	Linear	
<b>Series</b>	<b>7</b>	-	
<b>Thrust</b>	<b>1</b>	1.2 kN (269 lbf)	0.9 kN (202 lbf) kN for AEL71T
	<b>2</b>	2.0 kN (449 lbf)	2.1 kN (472 lbf) for AEL72T
<b>Nominal Stroke</b>	<b>2</b>	30 mm (1.18")	
	<b>1</b>	230 Vac	
<b>Supply Voltage</b>	<b>2</b>	115 Vac	
	<b>3</b>	24 Vac	
<b>Speed</b>	<b>1</b>	Low	0-0.7 mm/s (0.028 in/sec)
	<b>F</b>	VMD	24 Vac
<b>Control Signal</b>	<b>G</b>	VMD	110 Vac
	<b>J</b>	VMD	230 Vac
	<b>P</b>	Modulating	(0)4-20 mA/0(2)-10V Positioner
<b>Failure Mode</b>	<b>T</b>	Spring	Non-retrofit option. Not available for 24 Vdc
	<b>X</b>	None	
<b>Potentiometer</b>	<b>A</b>	Potentiometer	1 x 1000Ω

## 2.3 Operating principle

The AEL7T Series is a range of linear electric actuators of various voltages and thrusts suitable for the modulation of Spirax Sarco Group valves either by means of VMD or modulating signal. Independent of the control method, the actuators typically uses stroke dependent (travel) switches to determine the end position of the actuator stroke in both directions and stop the actuator motor.

The potentiometer and positioner card (when fitted) are set to a predetermined stroke at the factory. This can be adjusted locally in order to suit the respective valve and provide optimum position control or feedback.

AEL7T versions have an integrated spring extend shut down capability. A maintained electrical supply operates an electromagnet which disengages a clutch mechanism. Disengaging the clutch allows the actuator to be modulated in response to the selected drive signal (VMD or modulating). In the event that power supply is interrupted, the electro-magnet is released allowing an internal spring mechanism to engage the clutch and drive the actuator windings to extend the spindle through its full travel.

	<p><b>Caution</b> A power supply must never be connected to the actuator whilst the spring shut down mechanism is in operation. This will lead to permanent damage to the gearbox. Do not use the DOWN travel button to set seat loading. This will lead to permanent damage to the valve seat.</p>
--	---

	<p>AEL7T actuators use a stroke dependent switch to determine end position. Care must be taken with the setting of these switches in order not to damage either valve or actuator.</p>
--	--

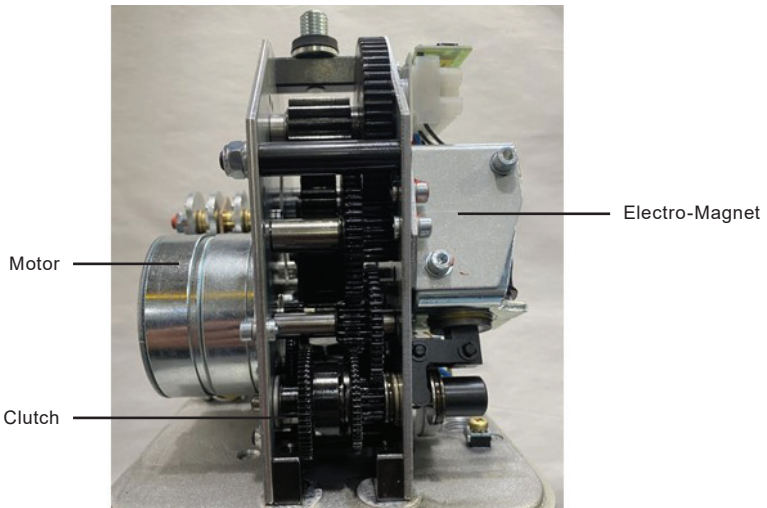
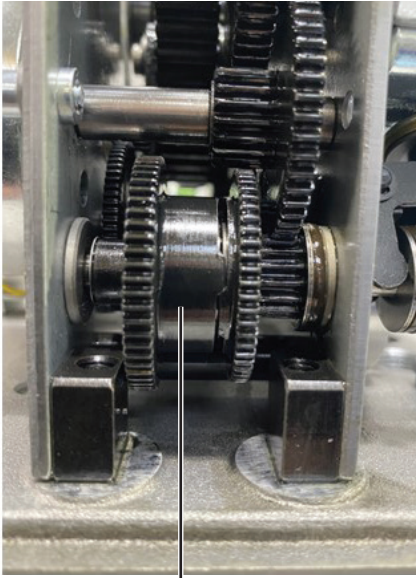
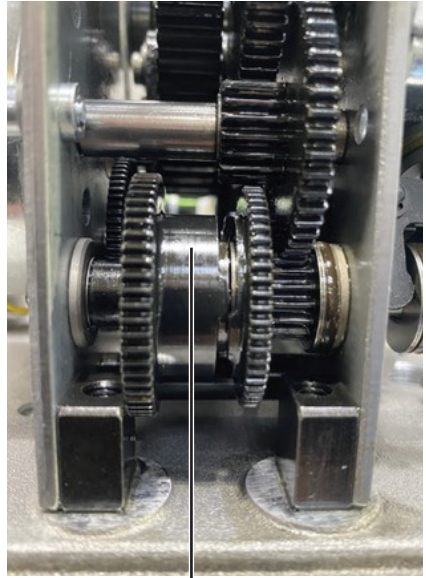

Fig. 2 General Arrangement of Actuator and Gearbox



Clutch couplings engaged

**Fig. 3 Clutch Engaged**



Clutch couplings disengaged

**Fig. 4 Clutch Disengaged**

## 2.4 EN14597 Compliance

The AEL7T Series actuator complies with EN14597 (2012) temperature control devices and temperature limiters for heat generating systems.

To comply with EN14597 (2012), as an electromagnetic device, the AEL7T actuator shall be suitable for continuous operation at VR +10% and the highest permissible ambient temperature. The actuator shall automatically close at a voltage level of VR -70% (i.e. the point at which the actuator clutch will disengage). Actuators are 100% factory tested before despatch in order to guarantee complete compliance with the standard.

When coupled with DN15 - 100 (Ø½" - 4") Spira-trol™ "K" or "L" Series valves (all body materials and connections) with seat type "T" (431 stainless steel) or seat type "P" (full PEEK), the complete valve assembly conforms to EN14597 (2012).

Use of all other seat types is not permitted for EN14597 (2012) applications. Refer to TI-P713-02 for details.

# 3. Electrical Connections



## Warning

The AEL7T Series actuator requires electrical connection to be made before it is possible to couple the actuator to a valve. Therefore the electrical connection must be made and the actuator cover replaced to make the unit safe to handle for the coupling stage.

## 3.1 Electrical Connection Safety Information



## Caution

Before commencement of any work to make the electrical please read to Section 1 "Safety Information".



## Warning

Mains connection and commissioning of the AEL7 Series actuator requires specialist knowledge of electrical circuits and systems, and the inherent dangers. A working knowledge of linear actuators is also required.

The operator is responsible for ensuring that safe systems of operation and practice are implemented and maintained. Only qualified personnel must be allowed to make the electrical power connections to the AEL7 Series actuator, and these personnel must be familiar with, and comply with the applicable health and safety standards or guidelines. Failure to do so could result in death, severe physical injuries or material damages to the actuator, valve and associated equipment.

- Ensure that the electrical power supply is isolated
- Safeguard against the unintentional switching on by ensuring that there is a safe system of practice in operation – e.g. lock the electrical supply isolator
- Ensure that any installation of any new power supply is compliant with local regulations
- Check the mains connection voltage and frequency for conformity to the actuator. Details of the requirements are identified on the AEL7 Series actuator nameplate which can be found on the actuator baseplate
- Ensure that the power supply cable is of the correct cross section for the maximum expected load. Details of the requirements are identified on the AEL7 Series actuator nameplate which can be found on the actuator baseplate, and in the Technical Information Sheet (TI-P713-02)
- Minimum cross section for the power supply cable is 1 mm<sup>2</sup>. Conductors below this area can result in operational disturbances
- Ensure that the power supply is correctly fused for the maximum expected load. Details of the requirements for each AEL7 Series actuator can be found in Table 1

**Table 1 Actuator Power Consumption**

Actuator Nomenclature	Thrust	Spindle Speed	Voltage (Vac)	Motor Power Consumption (W)	Maximum Current (A)	Magnet Power Consumption (W)
AEL71T	0.9 kN (202 lbf)	0.29 mm/s (0.011 in/sec)	230 Vac	2.7	0.026	15
			115 Vac	2.7	0.052	
			24 Vac	2.8	0.255	
AEL72T	2.1 kN (472 lbf)		230 Vac	2.7	0.026	
			115 Vac	2.7	0.052	
			24 Vac	2.8	0.255	

### 3.2 Removing the Actuator Cover

Remove the cover retaining nut and gasket (16 mm A/F socket). Gently ease the cover up and off the ingress seal.

	<p>When replacing the cover ensure that location thread and cover are correctly aligned. Gently lower the actuator cover until it meets the ingress seal. Firmly press down the actuator cover with several small clockwise and anti-clockwise movements of the cover to ensure correct engagement. Refit gasket and top nut and tighten to 2.5Nm.</p>
---	--

### 3.3 Making the Electrical Connection

A terminal diagram for the actuator can be found inside the actuator cover and this issue of the Installation and Maintenance Instructions. The operator is responsible for ensuring that safe systems of operation and practice are implemented and maintained and the installation and maintenance instructions should form part of the standard operating procedures for maintenance and must therefore be kept in an accessible location and in a legible condition.

With the power supply safely isolated and the actuator cover removed:

- Remove the blanking caps and fit the correct cable glands for the location. Dispose of the blanking caps responsibly
- Feed the electrical power supply cable through the cable gland until enough length exists within the actuator to make all of the necessary connections easily
- Mark the power supply cable approximately 10 mm (0.39") above the actuator base plate, remove from the gland and carefully strip the outer casing and wrapping. Dispose of the waste responsibly
- Strip the individual cores at a length of approximately 5 mm (0.20") from the end, and once the correct lengths of the individual cores has been established, the ends should be crimped with the correctly sized and insulated crimp terminals (flat or pin type)
- Guide the cores of the power supply cable through the gland sleeve and gland, and connect the cores to the actuator terminals as identified in the terminal diagrams below (or in the cover of the actuator) taking care to ensure that the routing of the cores protects them from damage of moving parts or from damage when replacing or removing the actuator cover

### 3.4 Electrical Connection

See below for all AEL7T actuator electrical connections unless otherwise stated

Power Supply (Vac)							Modulating Signal					
VMD							Setpoint			Position Feedback		
2	3	40	N		54	55	57	56	59	58	60	61
▲	▼	-	-	-	-	-	▲	▲	-	▼	▼	
L+	L-	L1	N	PE	L	N	GND	V+	mA+	GND	mA+	V+
Direction Open	Direction Close	Maintained Live	Neutral	Earth	Live	Neutral	Ground	Control Voltage	Control mA	Ground	Active Position feedback mA+	Active Position feedback V+

Fig.5 AEL7T actuator electrical connections



Options											
Heater		Potentiometer			Position Switches						
7	8	25	26	27	16	17	18	19	20	21	
-	-	▲	-	▼	-	-	-	-	-	-	
L	N	L	GND	S+	(NC)	COM	(NO)	(NC)	COM	(NO)	
Heater		Feedback signal (passive)			Potential free position Switch S3			Potential free position Switch S4			

## 4. Installation

Before considering installation of an AEL7 Series actuator please read to Section 1 "Safety Information" on page 5.

	<ul style="list-style-type: none"><li>- <b>Installation awareness</b><ul style="list-style-type: none"><li>- Lifting and fitting of actuators increases the risk of personal injury</li><li>- Mains connection and commissioning of the AEL7 Series actuator requires specialist knowledge of electrical circuits and systems, and the inherent dangers. A working knowledge of linear actuators is also required.</li><li>- Risk of injury by moving parts. Ensure that that the control system is disabled and the electrical power supply is isolated to ensure that the valve and actuator do not move without warning.</li><li>- The incorrect use of power supplies to assist the installation, commissioning and maintenance of electrically actuated valve assemblies increases the risk of personal injury.</li><li>- Lifting and fitting or actuators increases the risk of personal injury</li></ul></li><li>- <b>Crush hazard</b><p>When actuators are to be fitted using lifting equipment <b>always</b> ensure that the actuator is carefully slung in order that it cannot fall. <b>Never</b> attempt to remove a control valve from the line by using the actuator as the lifting point. The actuator or the lifting equipment could become damaged.</p><p>Never stand under components that are being lifted. Head safety protection must always be worn when operating on or close to equipment where lifting operations are taking place.</p><p><b>Do not</b> place hands within the actuator yoke or on the stem when isolation of the electrical power supply has been removed.</p><p><b>Do not</b> attempt to restrict actuator stroke or movement, or increase seat load through the placing of objects within the actuator yoke. This practice could also result in the <b>loss of sight</b>.</p></li><li>- <b>Warning</b> <b>Muscular skeletal damage</b><p>For small actuators that do not require mechanical lifting aids, always ensure that manual lifting best practice is observed. Always use two personnel where possible and ensure that proper access is available in order to ensure a secure foothold.</p></li></ul>
---	---

### 4.1 Location

The actuator should be mounted above the valve and provide sufficient space to remove the cover and provide general ease of access. The actuator can be mounted in a vertical pipe, however this orientation should be avoided wherever possible. When selecting the location, make sure that the actuator is not exposed to an ambient temperature exceeding the range 0 °C (32 °F) to + 50 °C (122 °F).

The actuator enclosure is rated at IP54, but only when the lid is correctly fitted. It is recommended that adequate shelter is provided for outdoor installations. For internal installations where there is a risk of condensation a condensate heater should also be installed. Refer to Technical Information Sheets for details (T1-P713-02).

## 4.2 Operational Considerations – End Position and Stroke Settings

The AEL7T actuators require a stroke dependent (travel) switch to be set prior to commissioning the actuator. This is an important difference to the standard AEL7 Series without integrated spring shut down.

	<p>End position is set by a combination of spring pressure and stroke dependent switch in the extend position, and stroke dependent switch only for the actuator retract position. Refer to Section 4.5 for details.</p>
---	--

Stroke settings for new actuators are identified in Table 2. Optional auxiliary switches, when fitted, do not impact actuator stroke.

**Table 2 Actuator Stroke Setting**

Actuator	Thrust	Maximum Stroke	Set Stroke Positioner or Potentiometer
AEL71T	0.9 kN (202 lbf)	35 mm (1.38")	30 mm (1.18")
AEL72T	2.1 kN (472 lbf)	35 mm (1.38")	30 mm (1.18")

## 4.3 Manual Override

The AEL7T is not available with a manual override. The actuator is classified as a safety device (EN14597\_2012) and therefore in the absence of an electrical power supply, the valve must remain in a closed (safe) position.

The actuator can be moved by use of two push buttons located on the underside of the actuator base plate.

Movement of the actuator requires the power supply to be connected.

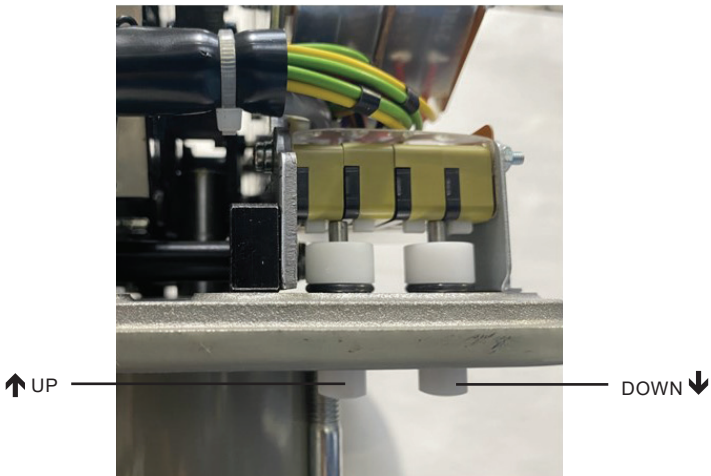

**Fig. 6 Travel Push Buttons**

## 4.4 Coupling the actuator to a Valve

The operator is responsible for ensuring that safe systems of operation and practice are implemented and maintained. Only competent persons must be allowed to be couple the AEL7T Series actuator to a valve, and these persons must be familiar with, and comply with the applicable health and safety standards or guidelines.



### Warning

The AEL7T Series actuator requires electrical connection to be made before it is possible to couple the actuator to a valve. Therefore the electrical connection must be made and the actuator cover replaced to make the unit safe to handle for the coupling stage.



### Warning - crush hazard Risk of injury by moving parts.

Ensure that the control system is disabled and the electrical power supply is isolated when not required during the assembly process to ensure that the valve and actuator do not move without warning. The incorrect use of power supplies to assist the installation, commissioning and maintenance of electrically actuated valve assemblies increases the risk of personal injury. Do not place hands within the actuator yoke or on the stem when isolation of the electrical power supply has been removed. Do not attempt to restrict actuator stroke or movement, or increase seat load through the placing of objects within the actuator yoke. This practice could also result in the loss of sight. Only competent engineers should attempt the coupling of AEL7T actuator to a valve.



In the state of delivery, the AEL7T will always be in the maximum spindle extend position as a result of the spring shut down system being extended without power supply connected.

Consult TI-P713-02 ensure you have the correct valve and actuator for your application.

With the actuator correctly connected (as per Section 3 – Electrical Connections), safely isolated and the actuator cover correctly fitted:

- Remove the actuator retaining nut from the valve and place the mounting flange over the valve bonnet thread
- Refit the actuator retaining nut and tighten (50 Nm for M34 or 100 Nm for M50)
- Remove the actuator pillar nuts
- Untighten the four screws and remove the valve adapter locking plate, anti-rotation plate and valve adapter bush from the actuator
- Place the locking plate and the anti-rotation plate over the valve stem
- Set the valve stem lock nut at the correct Thread Engagement dimension "A" (Fig. 7 and Table 3) for the relevant valve and actuator combination and thread the valve adaptor bush up to the lock nut

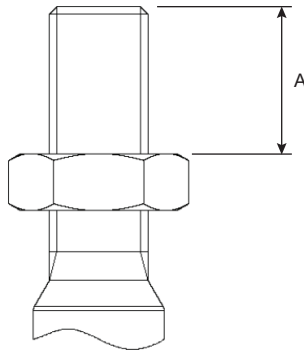

**Fig. 7 Thread Engagement**

**Table 3 Thread Engagement**

Actuator Thrust	Spira-trol™ K & L 2-Port Valves		
	DN15 to 50 (½" to 2")	DN65 to 100 (2½" to 4")	DN125+ (5" +)
0.9 kN (202 lbf)	12 mm (0.47")	15 mm (0.59")	n/a
1.2 kN (270 lbf)			

- Apply electrical power supply to the actuator taking care for any sudden movements
- Using the UP travel push button, retract the actuator spindle by approximately 25% of valve stroke to ensure that the valve is coupled with the plug away from the seat in order to prevent valve damage
- Raise the plug from the valve seat by approximately 25% of the rated valve stroke
- Lift the actuator over the valve stem and place onto the mounting flange and loosely refit the actuator pillar nuts raise the valve plug to the actuator until the threaded bush meets the actuator coupling



Before the pillar nuts are tightened, make sure that the pillar ends are completely inserted into the bores of the valve mounting flange. If necessary, correct the position of the actuator using the relevant UP or DOWN travel push button.

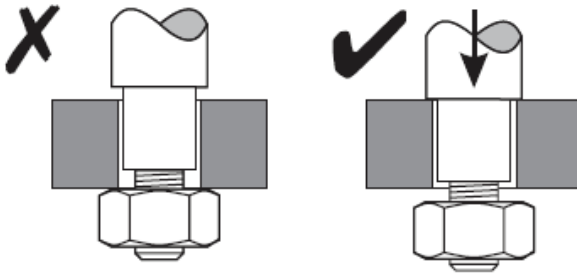



Fig. 8

- With the valve adapter and actuator spindle aligned correctly, and with the plug off the valve seat, couple the indicator plate
- Couple the adapter locking plate
- Tighten the pillar nuts to 30 Nm
- Tighten the (4) valve adaptor screws to 8 Nm
- Tighten the thread lock nut to 15 Nm

## 4.5 Setting the end position

	<p><b>Warning</b></p> <p>Operation of the AEL7T actuator without the protection of the cover must only be used for the short term commissioning or replacement of parts (positioner, potentiometer, auxiliary switches of heater). During this activity there exists access to live electrical connections and moving parts. In case of inappropriate or incautious execution of the installation and commissioning works there is a danger of death or serious physical injury to the operator, and irreparable damage to the actuator. Only suitably qualified personnel can operate the actuator under these conditions (Section 1.20). The actuator must not be operated under normal conditions with the cover removed.</p>
---	--

	<p><b>Caution</b></p> <p>Do not use the DOWN travel button to set seat loading. This will lead to permanent damage to the valve seat. A power supply must never be connected to the actuator whilst the spring shut down mechanism is in operation. This will lead to permanent damage to the gearbox.</p>
---	--

With the actuator correctly coupled to the valve with all bolts or nuts tightened as described:

- Remove the actuator cover
- Cut off and isolate all power supply voltage to the actuator simulating voltage failure in the field
- The electro-mechanical clutch will disengage and fail-safe spring will extend the actuator until the valve plug meets the corresponding valve seat
- Adjust the lower stroke indicator ring on the actuator pillar until it meets the indicator plate
- Using an insulated screwdriver (blade width 3 mm) adjust S1 cam until it touches but does not actuate the S1 travel dependent switch. Pay attention to the direction of cam operation and hold fast the output wheel when any of the cams (travel dependent or auxiliary) are adjusted. The cam shaft rotates clockwise when the actuator spindle is extending. Refer to Fig. 9 to Fig. 12 for identification and orientation

	<p>It is important to identify that the actuator applies maximum thrust to the seat when it closes under the momentum of both the spring or the motor.</p> <p>As the driving rod is already in the closed position, the gear (upon approaching the end position by means of the motor) will be moving to the end position until the travel dependent switch S1 is operated, stopping the motor. During this over run of the gear, the driving rod pin will move 1-1.5 mm down in the driving rod slot. This will ensure that the full closing pressure of the spring is available and the adjustment of the travel switch will not require an excessive diligence.</p> <p>Refer to Fig. 12 for orientation.</p>
---	---

	<p><b>Caution</b></p>
	<p>When using a PEEK seat option, caution is required when checking the operation of travel dependent switch S1. The actuator can generate a thrust far above the allowable seat load for the seat material resulting in irreparable damage.</p>
	<p>When checking the setting of travel dependent switch S1, operate the DOWN travel push button for a maximum duration of 1s each time to a maximum of 5 operations.</p>
	<p>If the travel dependent switch S1 is not actuated at this time, adjust the S1 cam to actuate the switch.</p>
	<p>If the 1-1.5 mm gap does not become apparent in this time, the thread engagement length must be adjusted and the setting of end position process repeated.</p>
	<p>Rotation of the cams can be quite stiff. In such circumstances it is recommended to fix the position of the adjacent cam with a second screwdriver and always start with the adjustment of S1 and finish with the adjustment of S4. Do not loosen the cam lock nuts under any circumstances other than for replacement (Fig. 9).</p>

- With the closed (actuator extend) position set, adjust the upper stroke indicator ring on the actuator pillar to match the desired travel of the valve

	<p>It is important to identify that the actuator travel is limited by the travel dependent switch S2 and not valve itself. If travel is restricted by the valve itself, damage to the gearbox will be the result. The spring failure function will remain unaffected however.</p>
---	---

- Apply electrical power supply to the actuator taking care for any sudden movements
- Using the UP travel push button, retract the actuator until the indicator plate meets the upper stroke indicator ring
- Using an insulated screwdriver (blade width 3 mm) adjust S2 cam until it actuates the S2 travel dependent switch. Pay attention to the direction of cam operation and hold fast the output wheel when any of the cams (travel dependent or auxiliary) are adjusted. Refer to Fig. 9 and Fig. 10 for identification and orientation

	<p>Rotation of the cams can be quite stiff. In such circumstances it is recommended to fix the position of the adjacent cam with a second screwdriver and always start with the adjustment of S1 and finish with the adjustment of S2. Do not loosen the lock nuts under any circumstances (Fig. 9).</p>
---	--



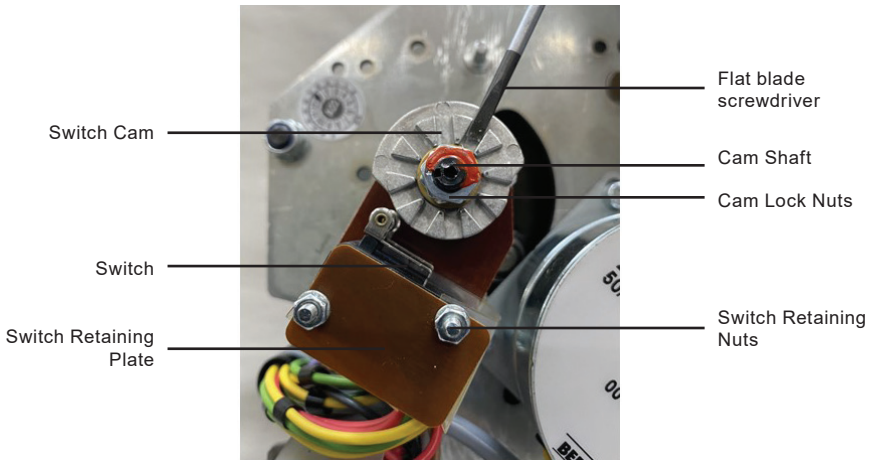

**Fig. 9 Switch Adjustment**

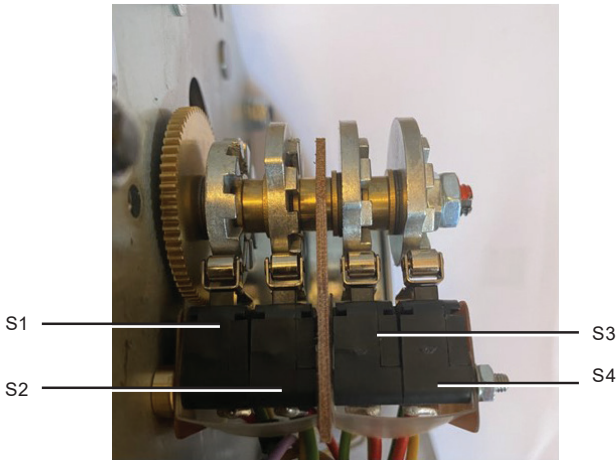

**Fig. 10 Switch Overview**

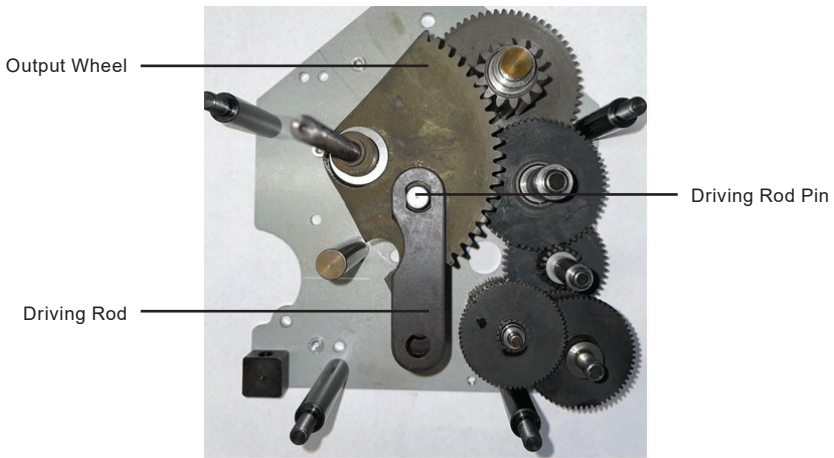

Fig. 11 Gearbox Overview

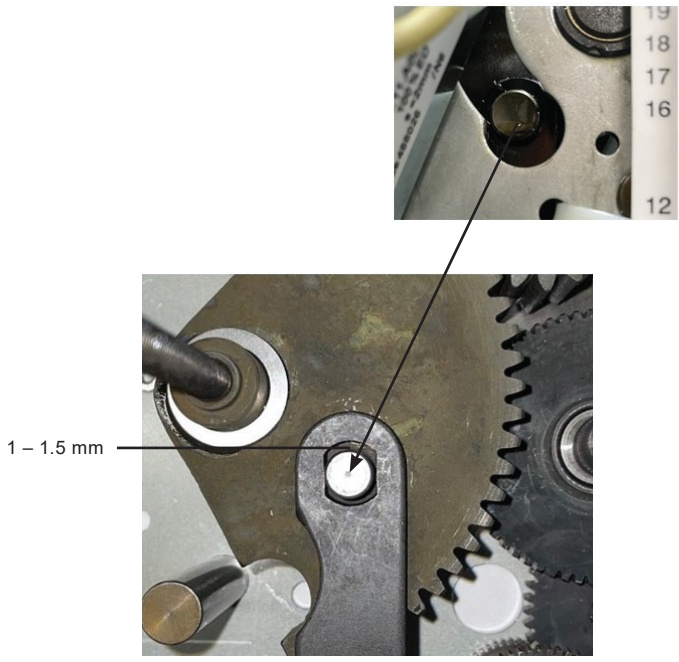



Fig. 12 Drive Rod Pin at End Position

# 5. Actuator Accessories

## 5.1 Actuator Accessory Safety Information

	<p><b>Warning</b>          Before commencement of any work to inspect, install, commission, remove or modify any of the AEL7 Series actuator accessories, please read to Section 1 "Safety Information". and Section 3.1 "Electrical Connection Safety Information".</p>
---	--

In order to select the correct accessories for each actuator, refer to Table 4. Because the AEL7T Series actuators are a safety device, it is recommended that the actuator is purchased with all of the required accessories direct from the factory.

**Table 4 AEL7T Accessories**

Actuator Type	Thrust	Voltage	Aux. Switch	Potentiometer	Positioner	Heater
AEL7T	1 kN (224 lbf)	230 Vac	AEL7T010	AEL7T001	AEL7X241	AEL7T191
		110 Vac			AEL7X233	AEL7T193
		24 Vac				
	2 kN (449 lbf)	230 Vac			AEL7X241	AEL7T191
		110 Vac				
		24 Vac			AEL7X233	AEL7T193

## 5.2 Auxiliary Travel Switches

The AEL7 Series actuator are equipped with auxiliary travel switches. The auxiliary travel switch is only a means of providing a Volt Free Contact enabling the user to identify when the actuator is in a user defined position. The auxiliary travel switches do not impact actuator stroke and be configured as either normally Open (NO) or Normally Closed (NC).

### 5.2.1 Replacement of Auxiliary Travel Switches

	<p><b>Caution</b></p> <p>A power supply must never be connected to the actuator whilst the spring shut down mechanism is in operation. This will lead to permanent damage to the gearbox. The auxiliary travel switches should be used make an indication that the valve is closed as a result of the spring fail safe mechanism operation and that it is therefore safe to restore the power supply if required.</p>
---	---

With the actuator spindle in the fully extended position, the power supply safely isolated and the actuator cover removed:

- Check the switch kit for compatibility, completeness and signs of damage. Reject any damaged parts immediately
- Refer to Fig. 9 for product orientation
- Remove switch retaining nuts and switch retaining plate, remove old switches
- Slide switch S3 first onto the switch retaining pins ensuring that orientation is as shown in Fig. 9. S3 has the shorter wiring harness
- Slide switch S4 onto the switch retaining pins ensuring that orientation is as shown in Fig. 9
- Replace the switch retaining plate and tighten the switch retaining nuts
- Connect the wiring harness from switch S3 to terminals 16-18, and switch S4 to terminals 19-21 as shown in Fig. 13 Auxiliary Travel Switch Terminal Diagram

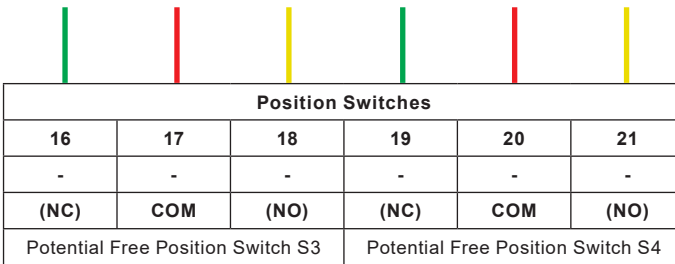

Fig. 13 Auxiliary Travel Switch Terminal Diagram

## 5.3 Potentiometer

The potentiometer is used to provide an internal position feedback for actuators fitted with a positioner card. For position feedback for actuators fitted with a positioner card see Section 6.4.

### 5.3.1 Replacement of Potentiometer



#### Caution

Before commencement of any work to inspect, install, commission, remove or modify the auxiliary travel switches, please read to Section 1 "Safety Information" and Section 3.1 "Electrical Connection Safety Information".

With the actuator spindle in the fully extended position, the power supply safely isolated and the actuator cover removed:

- Check the potentiometer kit for compatibility, completeness and signs of damage. Reject any damaged parts immediately
- Refer to Fig. 14 Potentiometer Installation and Adjustment for product orientation
- Remove the potentiometer plug from the positioner card
- Remove the potentiometer assembly plate
- Remove circlip and pinion from the potentiometer
- Remove the lock nut and washer from the potentiometer and remove potentiometer
- Slide the new potentiometer and spacer ring through the potentiometer assembly plate
- Loosely replace the washer and lock nut
- Slide the pinion onto the potentiometer shaft, taking care to ensure that the mesh with the stroke pinion is correct
- Tighten the lock nut and replace the potentiometer assembly plate
- Connect the potentiometer wiring harness plug to the positioner board
- Refer to Section 6.3 for commissioning

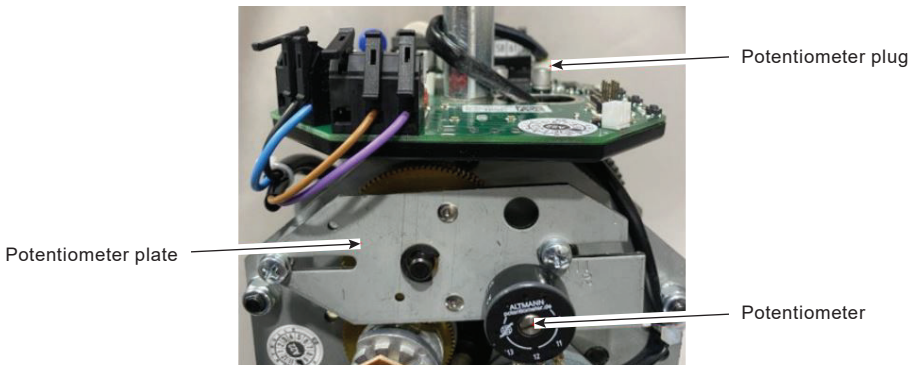

Fig. 14

## 5.4 Positioner Card

The positioner card is used to modulate the final control element in relation to an input signal (V or mA). The positioner card is the same unit that is used in the AEL7 Series actuator.

### 5.4.1 Installation of Positioner Card

With the actuator spindle in the fully extended position, the power supply safely isolated and the actuator cover removed:

- Check the positioner kit for completeness and signs of damage. Reject any damaged parts immediately
- Disconnect the power and signal supply cores, The DE wiring harness and the potentiometer plug from the positioner card
- Remove the top section of the cover bolt to expose a thread and remove the single washer from the positioner
- Remove the old positioner card and carefully slide the oval hole of the new positioner card over the exposed cover bolt thread
- Replace the washer and the top section of the cover bolt thread and tighten taking care to ensure that the actuator cover can fit over the positioner card once the cable cores are terminated
- Connect the potentiometer plug to the potentiometer socket on the positioner card (the potentiometer wiring harness should be fed through the centre of the positioner card)
- Connect the DE wiring harness as indicated in Fig. 15
- Refer to Section 6.4 for commissioning information

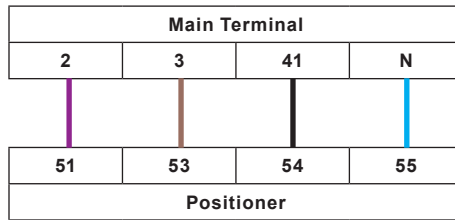



Fig. 15 Positioner Installation Terminal Diagram

# 6. Commissioning

## 6.1 Commissioning Safety Information

	<p><b>Caution</b> Before commencement of any commissioning works, please read to Section 1 "Safety Information". and Section 3.1 "Electrical Connection Safety Information".</p>
---	--

	<p><b>Warning</b> Mains connection and commissioning of the AEL7 Series actuator requires specialist knowledge of electrical circuits and systems, and the inherent dangers. A working knowledge of linear actuators is also required. Only suitably qualified personnel can operate the actuator under these conditions (Section 1.20). Risk of injury by moving parts. Ensure that the control system is disabled and the electrical power supply is isolated when not required during the assembly process to ensure that the valve and actuator do not move without warning. The incorrect use of power supplies to assist the installation, commissioning and maintenance of electrically actuated valve assemblies increases the risk of personal injury. Warning - crush hazard Do not place hands within the actuator yoke or on the stem when isolation of the electrical power supply has been removed. Do not attempt to restrict actuator stroke or movement, or increase seat load through the placing of objects within the actuator yoke. This practice could also result in the loss of sight.</p>
---	--

## 6.2 Adjustment of Auxiliary Travel Switch

	<p><b>Caution</b> Before commencement of any work to inspect, install, commission, remove or modify the auxiliary travel switches, please read to Section 1 "Safety Information", Section 3.1 "Electrical Connection Safety Information" and Section 6.1 "Commissioning Safety Information"</p>
---	---

The AEL7T Series actuator is supplied with two auxiliary switches (S3 and S4). The S3 and S4 auxiliary travel switches can be used to notify the user of a user defined valve and actuator position by means of a volt free contact (VFC). Refer to Fig. 10 for product orientation.

	<p>Rotation of the cams can be quite stiff. In such circumstances it is recommended to fix the position of the adjacent cam with a second screwdriver and always start with the adjustment of S3 and finish with the adjustment of S4. Do not loosen the lock nuts under any circumstances (Fig. 9). The auxiliary travel switches do not impact the operation of the actuator. None, one or two can be configured as required.</p>
---	---

With the actuator spindle in the fully extended position, and the actuator cover removed:

- If the lower auxiliary switch is to be set with the valve in the closed position; Carefully insert an insulated terminal screwdriver in one of the S3 cam slots and holding the output wheel steady, turn the cam slowly until the point that the switch S3 just actuates (confirm with a measurement instrument if necessary)
- If the lower switch is to be actuated at a position other than closed, using the UP travel push button, drive the actuator to the desired actuator travel for the lower switch to actuate
- Carefully insert an insulated terminal screwdriver in one of the S3 cam slots and holding the output wheel steady, turn the cam slowly until the point that the switch S3 just actuates (confirm with a measurement instrument if necessary)
- Using the UP travel push button, drive the actuator to the desired actuator travel for the upper switch to actuate
- Carefully insert an insulated terminal screwdriver in one of the S4 cam slots and holding the output wheel steady, turn the cam slowly until the point that the switch S4 just actuates (confirm with a measurement instrument if necessary)
- Refer to Fig. 13 Auxiliary Travel Switch Terminal Diagram to ensure that the VFC is correctly configured to the control system requirement (NO or NC)



## 6.3 Commissioning of Potentiometer

The potentiometer resolution should be matched to the travel of the actuator (set between seat/S1 and S2).

	<p><b>Caution</b> Before commencement of any work to inspect, install, commission, remove or modify the potentiometer, please read to Section 1 "Safety Information", Section 3.1 "Electrical Connection Safety Information" and Section 6.1 "Commissioning Safety Information"</p>
---	---

With the actuator spindle in the fully extended position, the power supply safely isolated and the actuator cover removed:

- Loosen the potentiometer assembly plate by untightening both fixing screws by a few turns
- Adjust the desired stroke according to the scale to match the desire travel and retighten the fixing screws
- Using an insulated flat blade terminal screwdriver, turn the slotted potentiometer shaft to the corresponding mechanical turn limit
- Reinstall power supply voltage and using the UP travel push button drive the actuator until travel dependent switch S2 is actuated. Use a measuring device to witness the potentiometer motion and determine whether the span is correct or not

## 6.4 Commissioning of Positioner Card

	<p><b>Caution</b> Before commencement of any work to inspect, install, commission, remove or modify the positioner card, please read to Section 1 "Safety Information", Section 3.1 "Electrical Connection Safety Considerations" and Section 6.1 "Commissioning Safety Information".</p>
---	---

	<p><b>Warning</b> Do not use the hand wheel or hand crank when either electrical power supply of control signal are applied. The actuator may respond to manual interaction resulting in muscular-skeletal damage to fingers.</p>
--	---

	<p><b>Caution</b> It is possible to damage the force dependent switches by applying excessive load by use of the hand wheel or hand crank.</p>
---	--

The positioner card requires a potentiometer to be fitted in order to operate. The positioner card is fitted with a series of DIP switches that can be used to configure:

- Input signal
- Feedback signal
- Direction of action
- Hysteresis
- Failure mode (loss of control signal only)
- Seating (commissioning) function



For split range applications refer to addendum IM.

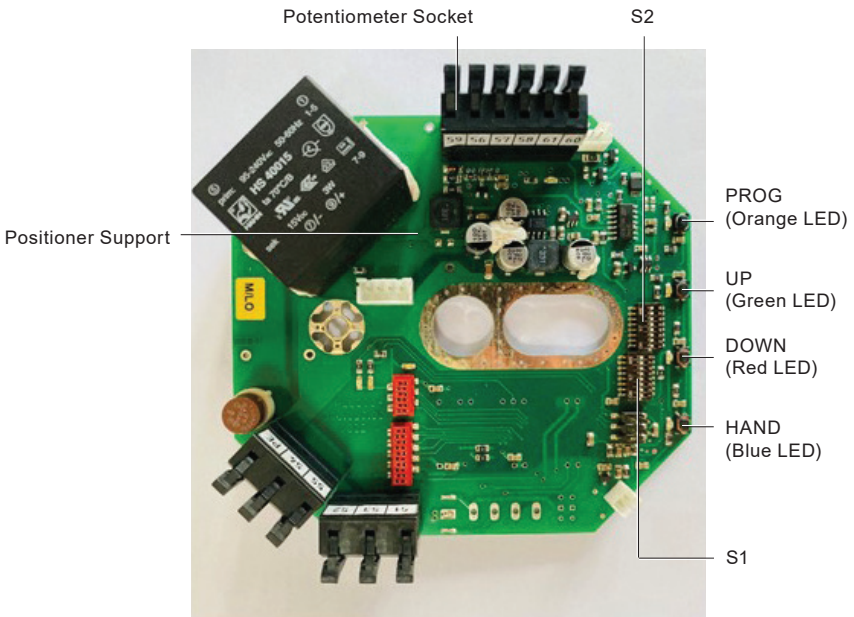

Fig. 16



The setting of DIP switches will be updated after power on or reset by simultaneous pressing HAND+UP+DOWN+PROG buttons.

**Table 5 DIP Switch Configuration**

DIP switch SW1			
Switch Nr.	Function	OFF	ON
S1.1	Setting of stroke	Off	On
S1.2	Action	Direct *	Reverse
S1.3 S1.4	Potentiometer	Internal *	n/a
S1.5	Signal range	4-20 mA/2-10 V*	0-20 mA/0-10V
S1.6	n/a	n/a	
S1.7 S1.8	Hysteresis	See Table 13	

DIP switch SW2			
Switch Nr.	Function	OFF	ON
S2.1	AUTOTUNE	Off	On
S2.2 S2.3 S2.4	n/a	n/a (set to Off)	
S2.5 S2.6	Failure mode	See Table 14	
S2.7 S2.8	Seating	See Table 15	

**Table 6 Hysteresis Configuration**

S1.7	S1.8	Hysteresis
Off*	Off*	1.5%
On	Off	1.0%
Off	On	0.5%
On	On	0.3%

**Table 8 End Position Configuration**

S2.7	S2.8	Seating
Off*	Off*	WE/WE
On	Off	DE/WE
Off	On	WE/DE
On	On	DE/DE

**Table 7 Failure Mode Configuration**

S2.5	S2.6	Failure mode
Off*	Off*	Extend
On	Off	Fail in place
Off	On	X=100%
On	On	X=0%

\* Indicates default setting

## 6.5 AUTOTUNE – Quick Set-Up

For the majority of applications a quick set-up routine can be adopted.

With the actuator spindle in the fully extended position, the power supply safely isolated and the actuator cover removed:

- Ensure that the potentiometer is in the zero position (confirm with a measurement instrument if necessary)
- With reference to Table 5 "DIP Switch Configuration"
- Select the action required with S1.2 (default is actuator stem extended at minimum input signal)
- Select the control signal required with S1.5 (default is 4-20 mA/2-10V) – Note: the feedback signal from the positioner automatically updates to the chosen input signal
- It is recommended that the hysteresis remain at 1.5% except in exceptional circumstances (refer to Table 6 Hysteresis Configuration)
- Select the desired failure mode. This function requires the power supply to still be operational. For Steam systems, it is recommended that both S2.5 and S2.6 be set to "OFF" (Table 7 Failure Mode Configuration)
- Set both S2.7 and S2.8 to "ON" (Table 8 End Position Configuration). This will allow the positioner to operate the valve through the full stroke, using the two physical force dependent (torque) switches to determine the end position of the actuator stroke in both ways i.e. it uses the end stops within the valve in order to determine stroke. The force dependent switches do not require any adjustment to correspond to valves with different lengths of stroke
- Manually move the valve off its seat approximately 20-50%



### Warning

The AUTOTUNE function will cause the valve and actuator to move. Make certain that all outcomes have been properly accounted for. The AUTOTUNE function can be stopped by pressing and holding any button during the commissioning cycle

- When it has been identified as safe to do so, reconnect the power to the actuator
- Set S2.1 to ON
- Press and hold "PROG" button for 3 seconds (orange LED flashes, turning solid with solid red and solid green LED)
- Press "HAND" button (blue LED illuminates)
- The actuator will retract until the lower force dependent switch is made as a result of the valve limits
- The actuator will then extend until the upper force dependent switch is made as a result of the valve limits
- When commissioning is complete, the red and green LEDs will switch off; "PROG" LED which will flash.
- Set S1.2 to OFF and apply a modulating signal. The actuator movement will now correspond to the input signal

# 7. Maintenance

## 7.1 Maintenance Safety Information

	<p><b>Caution</b> Before commencement of any commissioning work please read to Section 1 "Safety Information". and Section 4.1 "Electrical Connection Safety Considerations".</p> <p>Always read the Safety Information Sections of the relevant Installation and Maintenance Instructions for the control valve and any accessories as well as the actuator before commencing any work.</p>
---	--

	<p><b>Warning</b> Always ensure that the control valve is isolated and all necessary risk assessments and method statements have been validated and authorized prior to commencing maintenance operations.</p> <p>Mains connection and maintenance of the AEL7 Series actuator or control valve requires specialist knowledge of electrical circuits and systems, and the inherent dangers. A working knowledge of linear actuators and control valves is also required.</p> <p>Risk of injury by moving parts. Ensure that that the control system is disabled and the electrical power supply is isolated to ensure that the valve and actuator do not move without warning.</p> <p>The incorrect use of power supplies to assist the installation, commissioning and maintenance of electrically actuated valve assemblies increases the risk of personal injury.</p> <p>Lifting and fitting of actuators increases the risk of personal injury</p> <p><b>Warning - crush hazard</b> When actuators are to be fitted using lifting equipment ALWAYS ensure that the actuator is carefully slung in order that it cannot fall. NEVER attempt to remove a control valve from the line by using the actuator as the lifting point. The actuator or the lifting equipment could become damaged.</p> <p>Never stand under components that are being lifted. Head safety protection must always be worn when operating on or close to equipment where lifting operations are taking place.</p> <p><b>Do not</b> place hands within the actuator yoke or on the stem when isolation of the electrical power supply has been removed.</p> <p><b>Do not</b> attempt to restrict actuator stroke or movement, or increase seat load through the placing of objects within the actuator yoke. This practice could also result in the <b>loss of sight</b></p> <p><b>Warning - muscular skeletal damage</b> For small actuators that do not require mechanical lifting aids, always ensure that manual lifting best practice is observed. Always use two personnel where possible and ensure that proper access is available in order to ensure a secure foothold.</p>
---	---

## 7.2 General Maintenance of Actuator

The AEL7 is a low maintenance actuator. Routine or periodic maintenance is not required under normal operational demands.

The following parts can be replaced in the event of a break-down. Please refer to the relevant section of this document for details.

- Auxiliary travel switches
- Potentiometer
- Anti-condensation heater
- Positioner card
- Valve adaptor

Elastomer sealing elements can be subject to deterioration and should be inspected at regular intervals and replaced if necessary.

## 7.3 Warranty, Repair and Spare Parts

The heavy duty AEL7 Series actuator is supplied with 36 month warranty from date of manufacture or 24 months in operation (whichever is soonest). The warranty is for the defective manufacture and assembly of the actuator. Failures as a result of poor installation of the actuator, the valve or as a result of poor system design and maintenance are outside of the scope of this warranty. Damage as a result of handling, improper repair works, negligence or chemical and electro-chemical influences are also out of the scope of any warranty consideration.

In the rare event that an actuator should fail in operation, please contact your local Spirax Sarco Sales Company for product return instructions.

The AEL7 Series actuator should not be repaired in the field. In the rare event that The AEL7 Series actuator should need to be repaired, the actuator must be returned to the factory with a full field failure report.

Spare parts for the actuator are only available when assembled by the factory in Germany. Please contact your local Spirax Sarco Sales Company for product return instructions.

## 7.4 Removing the Actuator from the Valve

	<p><b>Caution</b> Before commencement of any commissioning work please read to Section 1 "Safety Information", Section 4.1 "Electrical Connection Safety Considerations" and Section 7 "Maintenance Safety Information".</p>
---	--

	<p><b>Warning</b> The AEL7T Series actuator requires electrical connection to be made before it is possible to remove the actuator from a valve. Therefore the electrical connection must be made and the actuator cover replaced to make the unit safe to handle for the de-coupling stage.</p>
---	--

Sometimes it may be necessary to remove the actuator from the valve for general valve maintenance or to replace the actuator itself. In order to remove the AEL7T, a power supply must be maintained to the actuator in order to relieve the spring pressure from the valve:

- Use the UP travel button to drive the actuator to approx. 25-50% of valve travel
- Loosen the valve stem clamp nut
- Loosen the valve adapter and remove the anti-rotation and clamp plates
- Loosen the pillar nuts and remove the actuator from the valve
- Isolate the power and signal supply to the actuator, and remove the actuator cover
- Disconnect the power supply and control signal cable cores from the respective terminals (label for identification if not already done so)
- Loosen the cable gland nut(s) and carefully slide the power supply and control signal cables through the gland(s)
- Make safe the loose cables in case of accidental power restoration

To return or replace the actuator to the valve, refer to Section 4.4 "Coupling the Actuator to a Valve". To commission the actuator, refer to Section 6. "Commissioning".

## 7.5 Problem Solving

Observation	Possible Cause
<b>Actuator does not move (VMD)</b>	Supply voltage interrupted
	Supply fuse blown
	Motor failure
<b>Supply fuse blows</b>	Incorrectly sized fuse
	Incorrectly sized wire
	Poor cable core connection within the actuator
	Exposed cable cores within the actuator
<b>Valve does not achieve full stroke (0%)</b>	Incorrect control signal
	Actuator incorrectly coupled
	Interference within the valve
	Potentiometer incorrectly commissioned
<b>Valve does not achieve full stroke (100%)</b>	Positioner stroke incorrectly commissioned
	Incorrect control signal
	Actuator incorrectly coupled
	Interference within the valve
	Travel dependent switch restricting travel
	Potentiometer incorrectly commissioned
Positioner stroke incorrectly commissioned	
<b>Actuator does not respond to signal (positioner)</b>	Stroke arm incorrectly commissioned
	Control signal out of range (check voltage/ current)
	Positioner incorrectly commissioned
	Potentiometer failure
<b>Actuator moving continuously</b>	Poor PID set-up
	Motor capacitor failure



# 8. Declaration of Conformity

spiraxsarco.com

**spirax**  
**sarco** EN

## EU DECLARATION OF CONFORMITY

Apparatus model/Product: **Electric Linear Actuators:  
AEL7 Series**

Name and address of the manufacturer or his authorised representative: **Spirax Sarco Ltd,**  
Runnings Road  
Cheltenham  
GL51 9NQ  
United Kingdom

This declaration of conformity is issued under the sole responsibility of the manufacturer.

The object of the declaration described above is in conformity with the relevant Union harmonisation legislation:

2014/35/EU	Low Voltage Directive
2014/30/EU	EMC Directive
2006/42/EC	Machinery Directive

References to the relevant harmonised standards used or references to the other technical specifications in relation to which conformity is declared:

(Low Voltage Directive)	EN 61010-1:2010+A1:2019
(EMC Directive)	EN 61000-6-2:2005 EN 61000-6-4:2007 + A1:2011
(Machinery Directive)	EN 60204-1:2018 EN ISO 12100:2010

Signed for and on behalf of: **Spirax Sarco Ltd,**

(signature): 

(name, function): **N Morris**  
Compliance Manager, Steam Business Development Engineering

(place and date of issue): **Cheltenham**  
2022-09-26

GNP217-CE-C issue 1

Page 1/25

**AEL7T EN14597 Compliant Electric Linear Actuators**

**DECLARATION OF CONFORMITY**

Apparatus model/Product: **Electric Linear Actuators:  
AEL7 Series**

Name and address of the manufacturer or his authorised representative: **Spirax Sarco Ltd,  
Runnings Road  
Cheltenham  
GL51 9NQ  
United Kingdom**

This declaration of conformity is issued under the sole responsibility of the manufacturer.

The object of the declaration described above is in conformity with the relevant statutory requirements of:

- SI 2016 No.1101 \*    The Electrical Equipment (Safety) Regulations 2016**
- SI 2016 No.1091 \*    The Electromagnetic Compatibility Regulations 2016**
- SI 2008 No.1597 \*    The Supply of Machinery (Safety) Regulations 2008**

(\*As amended by EU Exit Regulations)

References to the relevant designated standards used or references to the other technical specifications in relation to which conformity is declared:

- SI 2016 No.1101 \*    EN 61010-1:2010+A1:2019**
- SI 2016 No.1091 \*    EN 61000-6-2:2005  
EN 61000-6-4:2007 + A1:2011**
- SI 2008 No.1597 \*    EN 60204-1:2018  
EN ISO 12100:2010**

Additional information:

Signed for and on behalf of: **Spirax Sarco Ltd,**

(signature): 

(name, function): **N Morris  
Compliance Manager  
Steam Business Development Engineering**

(place and date of issue): **Cheltenham**

**26 September 2022**

**GNP217-UK-C issue 1**

Page 1 of 1



