

**AEL6 Series**  
**Smart Electric Linear Actuators for**  
**DN15 to DN100 Control Valves**  
Software Installation Instructions

---

---

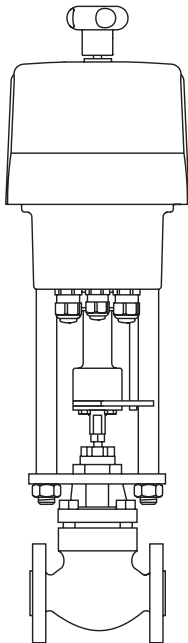

1. Safety information
2. General information
3. Licence agreement
4. Installation
5. Function
6. Menu structure
7. Fault finding

---

# 1. Safety information

---

Safe operation of this product can only be guaranteed if it is properly installed, commissioned, used and maintained by qualified personnel (see Section 1.13) in compliance with the operating instructions. General installation and safety instructions for pipeline and plant construction, as well as the proper use of tools and safety equipment must also be complied with.

See separate Installation and Maintenance Instructions for the control valve.



If the actuator is handled improperly or not used as specified, the resultant may:

- cause danger of the life and limb of the third party,
- damage the actuator and other assets belonging to the owner,
- hinder the performance of the actuator.

## 1.1 Wiring notes

Every effort has been made during the design of the actuator to ensure the safety of the user, but the following precautions must be followed:

- i) Maintenance personnel must be suitably qualified in working with equipment containing hazardous live voltages.
- ii) Ensure correct installation. Safety may be compromised if the installation of the product is not carried out as specified in this manual.
- iii) Isolate the actuator from the mains supply before opening the unit.
- iv) The actuator is designed as an installation category II product, and is reliant on the building installation for overcurrent protection and primary isolation.
- v) Wiring should be carried out in accordance with IEC 60364 or equivalent.
- vi) Fuses should not be fitted in the protective earth conductor. The integrity of the installation protective earth system must not be compromised by the disconnection or removal of other equipment.
- vii) A disconnecting device (switch or circuit breaker) must be included in the building installation. This must be in close proximity to the equipment and within easy reach of the operator.
  - There must be a 3 mm contact separation in all poles.
  - It must be marked as the disconnecting device for the actuator.
  - It must not interrupt the protective earth conductor.
  - It must not be incorporated into a mains supply cord.
  - The requirements for the disconnecting device are specified in IEC 60947-1 and IEC 60947-3 or equivalent.
- viii) The actuator must not be located in such a way that the disconnecting device is made difficult to operate.

---

## 1.2 Safety requirements and electromagnetic compatibility

This product is CE marked. It complies with the requirements of 73/23/EEC as amended by 93/68/EEC on the harmonisation of the law of Member States relating to electrical equipment designed for use within certain voltage limits (LVD), by meeting the standard for safety of electrical equipment for measurement control and laboratory use.

This product complies with the requirement of 89/336/EEC as amended by 92/31/EEC and 93/68/EEC on the approximation of laws of the Member States relating to Electromagnetic Compatibility, by meeting the generic standard of emissions for an industrial environment and the generic standard of immunity for an industrial environment.

The product may be exposed to interference above the limits of industrial immunity if:

- The product or its wiring is located near to a radio transmitter.
- Excessive electrical noise occurs on the mains supply.
- Cellular telephones and mobile radios may cause interference if used within approximately one metre of the product or its wiring. The actual separation necessary will vary according to the power of the transmitter.
- Power line protectors (ac) should be installed if mains supply noise is likely.
- Protectors can combine filtering, suppression, surge and spike arrestors.

For a copy of the declaration of conformity contact Spirax Sarco.

## 1.3 Intended use

Referring to the Installation and Maintenance Instructions, name-plate and Technical Information Sheet, check that the product is suitable for the intended use/application.

- i) Check material suitability, pressure and temperature and their maximum and minimum values. If the maximum operating limits of the product are lower than those of the system in which it is being fitted, or if malfunction of the product could result in a dangerous overpressure or overtemperature occurrence, ensure a safety device is included in the system to prevent such over-limit situations.
- ii) Determine the correct installation situation.
- iii) Spirax Sarco products are not intended to withstand external stresses that may be induced by any system to which they are fitted. It is the responsibility of the installer to consider these stresses and take adequate precautions to minimise them.

## 1.4 Access

Ensure safe access and if necessary a safe working platform (suitably guarded) before attempting to work on the product. Arrange suitable lifting gear if required.

## 1.5 Lighting

Ensure adequate lighting, particularly where detailed or intricate work is required.

## 1.6 Hazardous liquids or gases in the pipeline

Consider what is in the pipeline or what may have been in the pipeline at some previous time. Consider: flammable materials, substances hazardous to health, extremes of temperature.

---

## 1.7 Hazardous environment around the product

Consider: explosion risk areas, lack of oxygen (e.g. tanks, pits), dangerous gases, extremes of temperature, hot surfaces, fire hazard (e.g. during welding), excessive noise, moving machinery.

## 1.8 The system

Consider the effect on the complete system of the work proposed. Will any proposed action (e.g. closing isolation valves, electrical isolation) put any other part of the system or any personnel at risk?

Dangers might include isolation of vents or protective devices or the rendering ineffective of controls or alarms. Ensure isolation valves are turned on and off in a gradual way to avoid system shocks.

## 1.9 Pressure systems

Ensure that any pressure is isolated and safely vented to atmospheric pressure. Consider double isolation (double block and bleed) and the locking or labelling of closed valves. Do not assume that the system has depressurised even when the pressure gauge indicates zero.

## 1.10 Temperature

Allow time for temperature to normalise after isolation to avoid danger of burns.

## 1.11 Tools and consumables

Before starting work ensure that you have suitable tools and/or consumables available. Use only genuine Spirax Sarco replacement parts.

## 1.12 Protective clothing

Consider whether you and/or others in the vicinity require any protective clothing to protect against the hazards of, for example, chemicals, high/low temperature, radiation, noise, falling objects, and dangers to eyes and face.

## 1.13 Permits to work

All work must be carried out or be supervised by a suitably competent person. Installation and operating personnel should be trained in the correct use of the product according to the Installation and Maintenance Instructions.

Where a formal 'permit to work' system is in force it must be complied with. Where there is no such system, it is recommended that a responsible person should know what work is going on and, where necessary, arrange to have an assistant whose primary responsibility is safety.

Post 'warning notices' if necessary.

## 1.14 Handling

Manual handling of large and/or heavy products may present a risk of injury. Lifting, pushing, pulling, carrying or supporting a load by bodily force can cause injury particularly to the back. You are advised to assess the risks taking into account the task, the individual, the load and the working environment and use the appropriate handling method depending on the circumstances of the work being done.

## 1.15 Residual hazards

In normal use the external surface of the product may be very hot. If used at the maximum permitted operating conditions the surface temperature of some products may reach temperatures of 90°C (194°F).

Many products are not self-draining. Take due care when dismantling or removing the product from an installation (refer to 'Maintenance instructions').

---

## 1.16 Freezing

Provision must be made to protect products which are not self-draining against frost damage in environments where they may be exposed to temperatures below freezing point.

## 1.17 Disposal

Unless otherwise stated in the Installation and Maintenance Instructions, this product is recyclable and no ecological hazard is anticipated with its disposal providing due care is taken.

## 1.18 Returning products

Customers and stockists are reminded that under EC Health, Safety and Environment Law, when returning products to Spirax Sarco they must provide information on any hazards and the precautions to be taken due to contamination residues or mechanical damage which may present a health, safety or environmental risk. This information must be provided in writing including Health and Safety data sheets relating to any substances identified as hazardous or potentially hazardous.

---

# 2. General information

---

## 2.1 System requirements

To operate the software the following computer requirements have to be met as a minimum:

<b>Operating system:</b>	Windows 98, Windows 2000 or Windows XP
<b>Processor:</b>	Pentium minimum 300 MHz
<b>Free RAM:</b>	10 MB
<b>Interfaces:</b>	S232 or USB

---

# 3. License agreement

---

During installation of the software, the wording of a licence agreement is displayed. Please read this carefully and confirm with 'OK' if you agree with all points.

Copyright © Spirax-Sarco Limited 2012

## All rights reserved

Spirax-Sarco Limited grants the legal user of this product (or device) the right to use the Work(s) solely within the scope of the legitimate operation of the product (or device). No other right is granted under this licence. In particular and without prejudice to the generality of the foregoing, the Work(s) may not be used, sold, licensed, transferred, copied or reproduced in whole or in part or in any manner or form other than as expressly granted here without the prior written consent of Spirax-Sarco Limited.

---

# 4. Installation

---

## 4.1 Software PSCS

The software and all auxiliary files are included in the following application:

**Setup\_PSCS\_\_\_.exe**

The latest version is available from:

**www.PS-Automation.com** under '**News**' - '**Downloads**' - '**Options for smart actuators**'

Store this file to one of your drives and start the application. An 'Install Shield' will guide you through the whole installation.



**Attention: You need to have all access rights (Administrator) to be allowed to install the software PSCS and the driver for the USB-to-RS232-adaptor to your PC!**

## 4.2 USB-driver

The USB-driver is required if you use a USB-to-RS232-adaptor (virtual interface) at your PC instead of a physical RS232-interface (COM 1). After installing the software the installation of the USB-to-RS232-adaptor will then be started automatically. The driver provides a virtual serial interface on your PC for communication with the actuator. Please check the allocation of the virtual COM-port under:

**'Start**' - '**Control panel**' - '**System**' click on the '**Hardware**' - '**Device Manager**' after installation of the driver. For this, open in 'Device Manager' the tree 'Ports (COM und LPT)'. There the USB-driver 'Prolific USB-to-Serial Comm Port' has to be listed with a port allocation (e.g. COM 5). The installation files required for the USB-driver will be stored under ...**usb\_driver to the installation directory of the software PSCS**; from there they can be used for re-installation, if required.



**Attention: You must plug the USB-to-RS232-adaptor into the PC, and have all access rights to get the virtual interface displayed!**

**When using the USB-to-RS232-adaptor together with a virtual Bluetooth interface, a PC interface may be double-allocated (Bug in Windows XP). You can correct this under properties of the USB-driver 'Prolific USB-to-Serial Comm Port'. For this, click on the driver 'Prolific USB-to-Serial Comm Port' - right mouse button - 'Properties' - 'Interface properties' - 'Extended'. In the lower section of the displayed file card adjust the number of the COM-port. Click on the selection box to display all allocated COM-ports. Move the COM - port - allocation to a COM-port not used so far.**

### 4.3 Connection

4.3.1 Open the cover

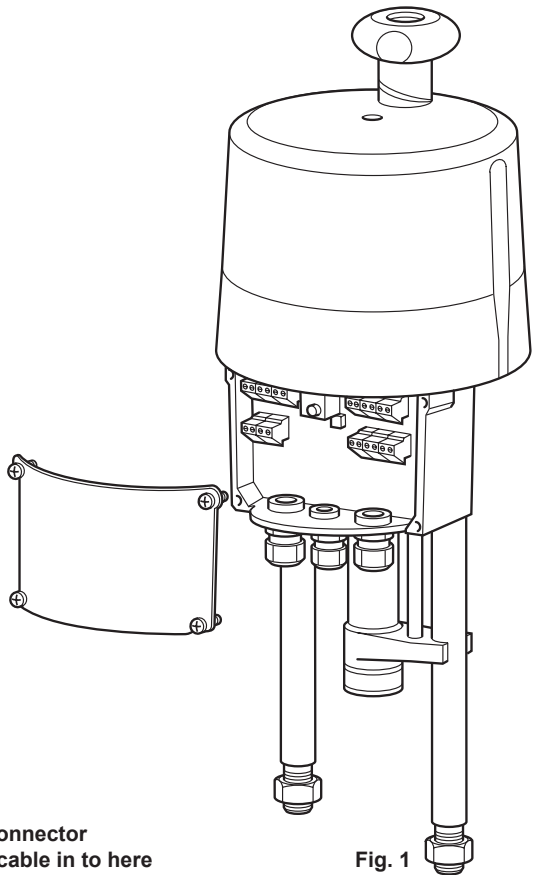

Fig. 1

4.3.2 Plug the RJ45 connector of the AEL6957 cable in to here

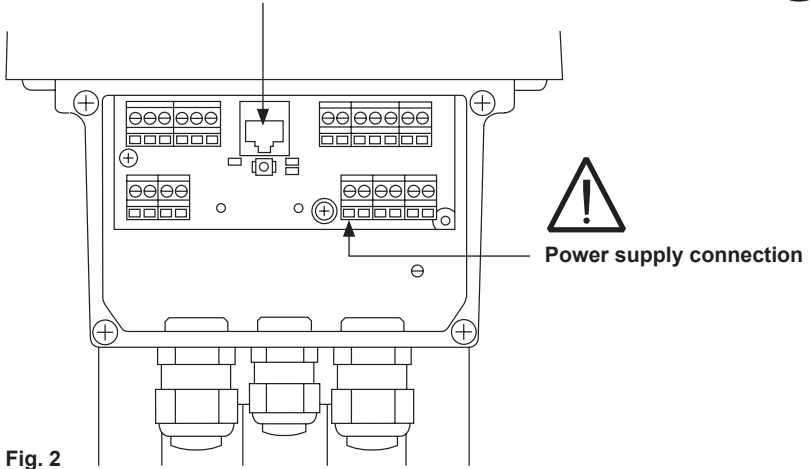

Fig. 2

# 5. Function

The software allows configuration, commissioning, diagnostic interrogation and monitoring of the AEL6 and smart PS-actuators of series AMS11 and AMS12.

# 6. Menu structure

## 6.1 Status window

Depending from where the active dataset has been loaded, the right hand section of the status window displays either (after loading from a data medium) the file name (1) of the active dataset, or (after loading from an actuator) the firmware version (2) and serial number (3) of the actuator, plus the current operating status in plain text (4).



Fig. 3

1

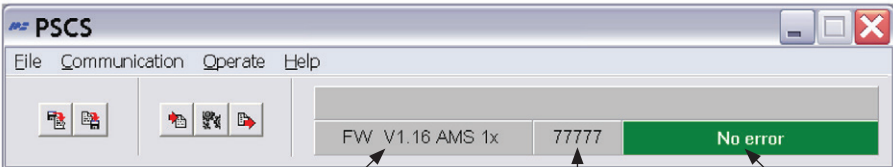







Fig. 4

2

3

4

## 6.2 Short cuts

- Fig. 5**  **Loads** a dataset of the type:  
- \*.ams (for actuators AMS01 / 02 / 03) or  
- \*.am1 (for actuators AMS11 / 12) from a data medium.
- Fig. 6**  **Stores** the current dataset as file of the type:  
- \*.ams or  
- \*.am1 to a data medium.
- Fig. 7**  **Loads** the active dataset from an operational actuator.
- Fig. 8**  **Opens** the window 'Parameter AMS' (same as 'Operate' - 'Configuration').
- Fig. 9**  **Transmits** the currently displayed dataset or the dataset edited lastly to the actuator.



## 6.3 File

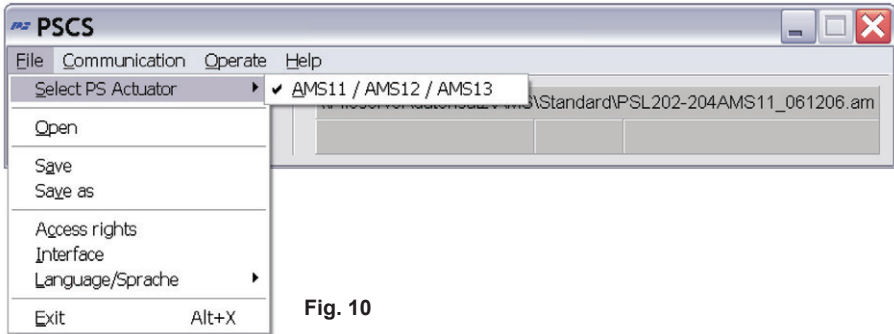

Fig. 10

This menu allows the following actions:

- **Select** an actuator type: at the moment actuators AMS11 / 12 / 13 are the only available.
- **File management** with 'Open', 'Save', 'Save as'.
- **Access rights** need not be entered for normal operation; it is required only for PS service staff.
  - The selection of the **Interface** (COM-port) as RS232 or USB by a selection window. This will be stored permanently to the PC; it has to be corrected only in case the interface structure of the PC is changed, or the software is newly installed. A routine for **automatic** allocation is available, which requires connection to an operational AEL6 actuator. This routine can lead to a system crash, if a large portion of the COM-ports of the PC is already in use. In this case, abort via Task Manager, and reduce the number of COM-ports in use while performing the routine.  
**Manual** allocation of the COM-ports is possible as well.
  - Selection of menu **language** (English or German).

## 6.4 Communication

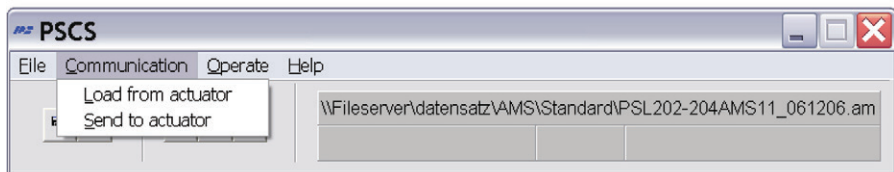

Fig. 11

This menu allows the following actions:

- **Load** the current dataset from the actuator to the software
- **Send** the displayed or lastly edited dataset to the actuator. Before sending, a dataset MUST be loaded, either from the actuator or from a data medium.
- **Close** an existing connection between the software and actuator, in case it seems to be instable or disturbed.

## 6.5 Operate

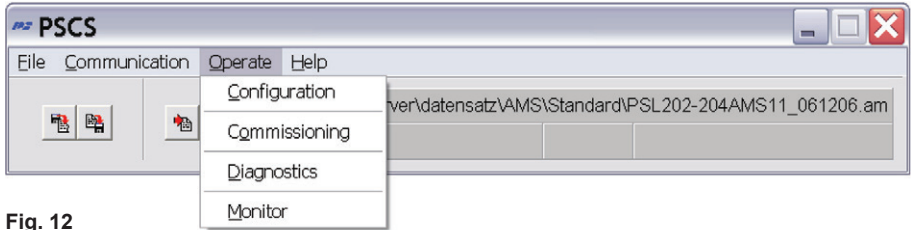
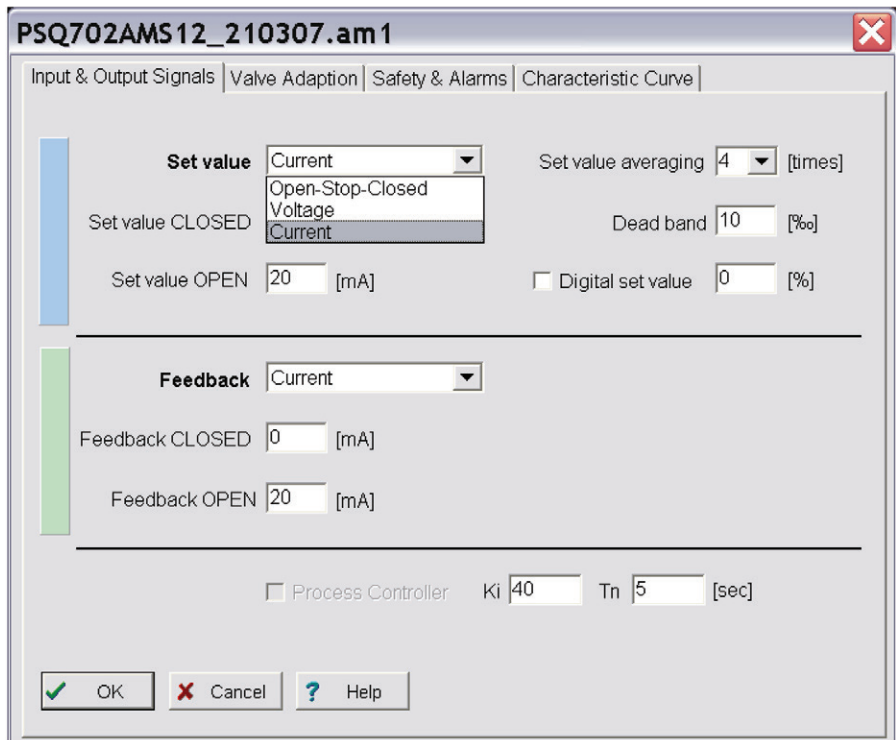

Fig. 12

### 6.5.1 Configuration

Changes of configuration in the software will be active in the actuator only after sending the dataset to the actuator. Changes on one or more pages have to be transferred to the temporary memory of the PC by confirming with 'OK' before leaving the page.

#### 6.5.1.1 Input and Output signals - Fig. 13



- Under **Set Value** the mode of control of the actuator has to be defined: as modulating set value (current or voltage input) or as 3-point control service (Open-Stop-Close). The range of values is 0 to 20 mA for the current signal and 0 to 10 V for the voltage signal. Upper and lower limits may be selected freely, even inverted, according to the process requirements.

- 
- **Open-and close-signals** have always got priority over the modulating and digital set value. This means that the actuator may be driven by phase signal for open / close even if control by modulating set value is selected. It drives to the respective direction as long as the phase for opening or closing is applied. After switching off the phase, the actuator returns to the position corresponding to the applied /entered set value, or drives to the position that is defined for 'Set value error'.
  - **Set Value Filter:** The applied set value is measured by the electronics inside the AEL6 actuator each 10 ms and the control deviation against the momentary position is calculated. The responding behaviour on this deviation is adjustable via the number of reading points (maximum 32 points) that are being averaged. A small number of points will result in quick reaction on process changes. Default setting is averaging over 8 points.
  - **Dead Band** allows adjustment in one-tenths of a percent of the maximum possible value of the set value range (20 mA and 10 V respectively) in the range of 5% to 50%. Default setting is 10%.
  - **Digital Set Value** is a fixed set value in % of the adjusted valve travel, activated by the tick box. It has priority over the modulating set value. Typical application is a fixed set-point control loop. Limit values for the modulating set value can be entered only if the fixed digital set value is inactive.  
Digital set value **must** be activated if the actuator is controlled via the optionally available bus interface!
  - **Feedback** allows configuration of an active position feedback. It can be selected as signal of current (in the range of 0 to 20 mA) or voltage (in the range of 0 to 10 V), with free choice of end points, depending on the process requirements.
  - **Process Controller:** An integrated PI-process-controller plus power supply output for an external process sensor is available as an option in the AEL6 actuator. If this option is included in the actuator, it may be activated by ticking the box in the menu. Adapting the controller to the behaviour of the control loop requires adjustment of delay time TN and amplification factor KP. The range of values is 50 msec to 100 sec for TN, and 1 to 250 for KP. A useful tool for doing this adjustment is the 'Monitor' function under 'Operate' in the software PSCS.

### 6.5.1.2 Valve adaption - Fig. 14

AMS1x Nr. 208753

Input & Output Signals | Valve Adaption | Safety & Alarms | Characteristic Curve

Closing direction: Valve stem retracting

Valve travel: 20 [mm] max:52[mm]

Cut-off Valve OPEN: Position

Cut-off Valve CLOSED: Torque

Torque increase: 50 [%] duration: 25 [x100ms]

Maximum force / torque: 100 [%]

Maximum speed: 100 [%]

Positions:

Position 1: 100 [%]

Position 2: 100 [%]

Position 3: 100 [%]

Position 4: 100 [%]

Position 5: 100 [%]

OK Cancel Help

- **Closing Direction** defines, with view on the valve, in which the actuator shall move the valve to closed position. It is displayed as **valve stem retracting / extending** (For example, for SPIRA-TROL valves with view on the valve, valve stem retracting closes the valve while valve stem extending opens the valve.). The allocation of 'open' and 'closed' positions for set value, feedback, etc. result from this field.
- **Valve Travel** defines the actual travel of the valve, in mm.
- The **Cut-Off** in either end position has to be selected dependent on the design of the valve, either **by position** or **by position automatic** or **by force/torque**. Automatic commissioning of the actuator to the valve is conducted if at least one cut-off is defined 'by position automatic' or 'by force/torque'.
- **Torque Increase** can be used to break away a closed valve from its seat. An increase by maximum 50% of the nominal force/torque for a maximum **duration** of 2.5 sec may be adjusted.
- **Maximum Force/Torque** and **Maximum Speed/Actuation time** allow a reduction of the switch-off force/torque and actuation speed to minimum 50% and an extension of the actuation time to maximum 200% with respect to the specific nominal values for an actuator.
- **Positions** allows to define up to 5 actuator positions that should be approached in the case of various failures of the actuator (see 'Safety and Failures').

### 6.5.1.3 Safety and alarms - Fig. 15

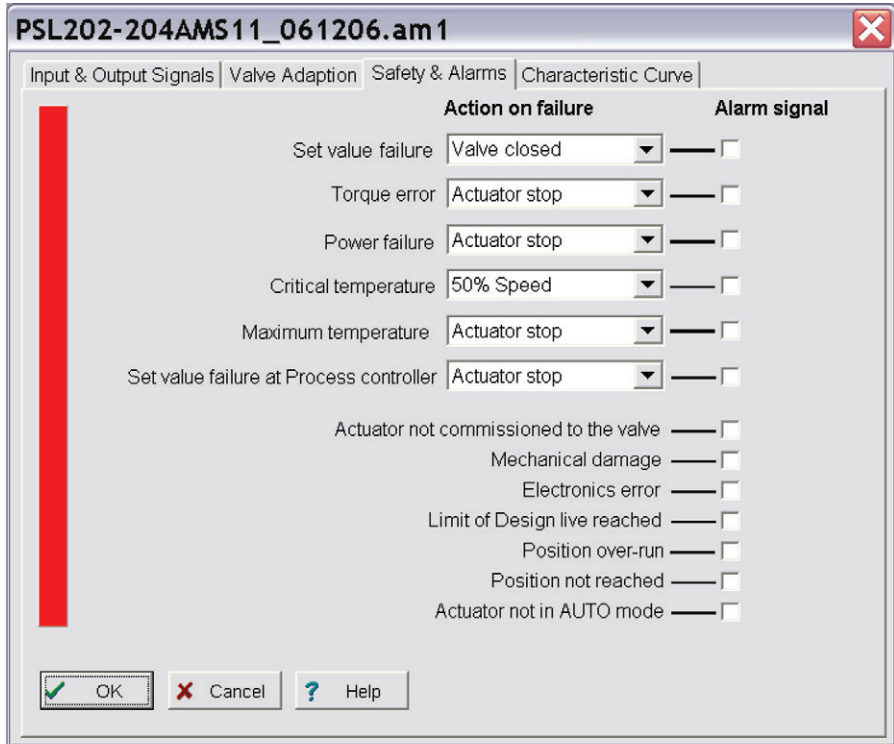

- All **Safety Functions** and **Statuses** listed here are displayed by two LEDs in the terminal compartment with specific light sequences. The optionally available potential-free monitor relay allows transmission of the ticked items as (summarised) binary alarm to a control board.
- **Set Value Failure** occurs if the applied set value is below 50% of the parameterised minimum set value. In this case the actuator may be driven to a selected position, or stopped immediately.
- **Torque Error** means that the actuator has to deliver the maximum adjusted force / torque apart from the stored end positions, for example when the valve plug is blocked. One option is to stop the actuator immediately ('Actuator Stop'). The other is to drive back (i.e. away from the found obstacle) and then again to the originally desired ('Retry') - up to three times; then the actuator will be stopped. After stopping, the actuator can only drive on in the direction opposite to the initial one.
- The safety function **Power Failure** is used to drive the valve to a freely selectable safety position. With the optional power fail-safe device the actuator drives to that position in case a loss of power supply is detected. If no fail-safe is installed, this safety drive may be activated by putting 230 Vac to the terminals 12/13 in the terminal compartment.

- 
- **Critical Temperature** inside the actuator indicates thermal overload, typically due to very high ambient temperature or excessive number of activations. As an instantaneous measure the actuator may be stopped in a selected position, or be driven with 50% of the adjusted speed, both of which will result in cooling down inside the actuator. During use as per specification however (see specific limits in the relevant data sheets) the critical temperature cannot be reached, so the reasons for this event have to be found and eliminated to ensure full lifetime of the actuator.
  - When **maximum allowed Temperature** is reached, the actuator has to stop in a selected position to avoid damage due to further heat generation in continuing operation. This maximum temperature is reached only at lack of success of the remedies on critical temperature. The reasons for this destructive rise in temperature have to be eliminated to prevent serious damage to the actuator and further disturbance of the process.
  - **Set Value Failure at Process Controller** indicates that the set value coming from the process sensor is below 50% of the parameterised minimum set value. In this case the actuator may be driven to a selected position, or stopped immediately.
  - **Actuator not commissioned to the valve** means that no commissioning has been performed with this actuator yet. This must be made after mechanical mounting in any case, and is done via 'Operate' - 'Commissioning', either automatically or manually, depending on the mode of cut-offs selected.
  - **Mechanical Damage** is displayed if no change in position of the actuator's output is detected with the motor turning for 120 sec and longer. The actuator is non-functioning and requires service.
  - **Electronics Error** reports an inconsistency of data in the actuator's internal memory. The actuator is non-functioning and requires service. A consistency check is done at each electronics start-up after switching on of the power supply.
  - **Limit of Design Life reached:** This function is not yet implemented.
  - A difference of more than 1.5% between actually reached position and calculated desired position results in a message of '**Position overrun**' or '**Position not reached**', depending on the direction of the deviation. This is for information only and does not affect the actuator's readiness for operation.
  - In case a local control panel is used with the actuator, by ticking this box the relay will indicate whether the selector switch is set to **AUTO mode** or not.

6.5.1.4 Characteristic curve - Fig. 16

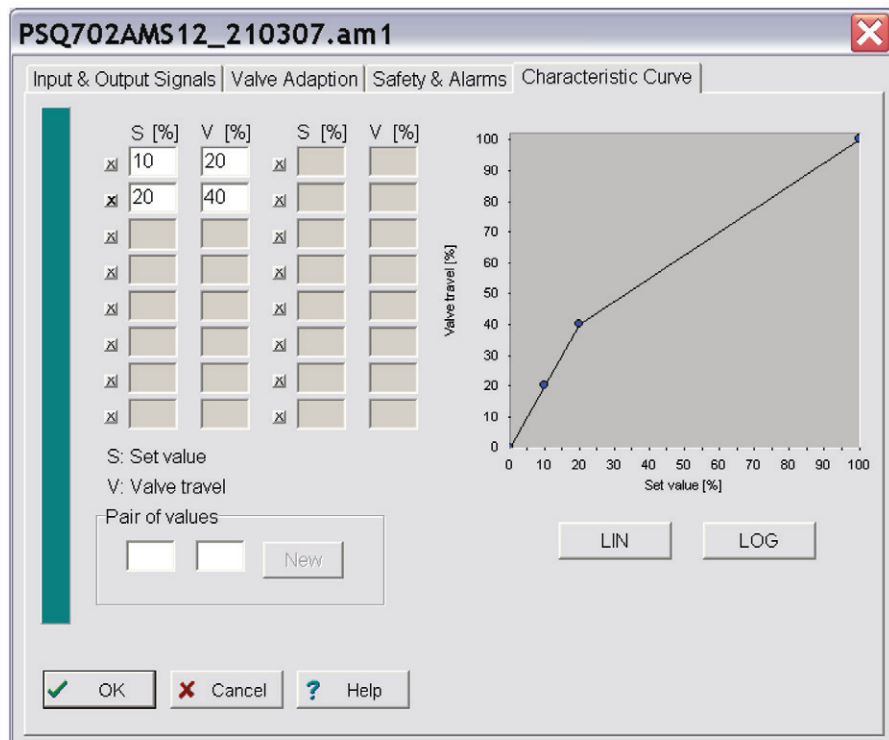

- The valve travel in reference to the set value may be modified by the actuator electronics. Linear (LIN) and equal-percentage (LOG) pre-defined characteristic curves are available via buttons. Furthermore, a free curve of up to 16 pairs of values may be defined. Enter the respective pairs for set value and actuator position to the field below 'Pair of values' and confirm with the button 'New'. They will then be transferred to the table above and to the graphics curve. The buttons marked 'x' activate / de-activate the respective pair.

---

## 6.5.2 Commissioning

After mechanical mounting, commissioning is mandatorily required to match the limits of the actuator to the end positions of the valve.

### 6.5.2.1 Automatic commissioning

Commissioning is conducted automatically if **at least one** end position is selected to be **by force / by torque** or **by position automatic**. After 'Operate' - 'Commissioning' and confirming the below window by 'OK' the actuator will drive to either end position and store the measured values permanently.

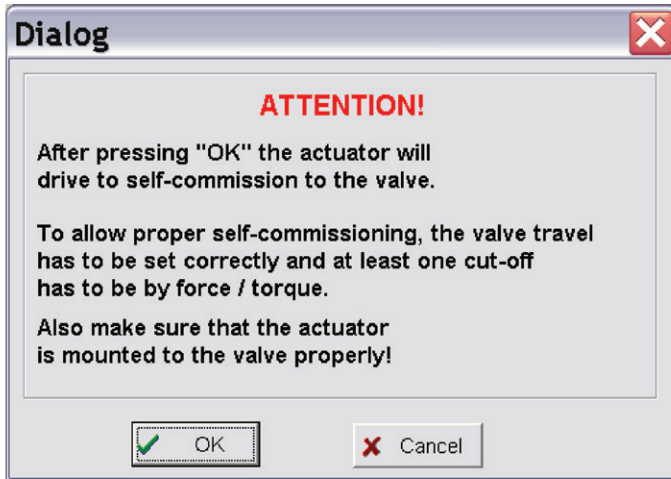

Fig. 17



### 6.5.2.2 Manual commissioning

Commissioning has to be made manually using the software if **both** end positions are selected **by position**.

**Warning:** When doing manual commissioning, make sure that the correct set value for the closed position, or the binary signal for driving to closed position is permanently applied, depending on the parameterised mode of operation - See 'Section 4. Commissioning' within IM-P358-24.

The window displays a sliding bar arrangement. The arrow (1) indicates the closed point of the valve relative to the total travel of the active actuator. This point is also displayed in the field aside (2) as percentage of the possible travel of the actuator. The vertical bar itself (3) above the arrow indicates the currently parameterised valve travel. It also shows how far the closed-point can be shifted before the travel is reduced automatically because it exceeds the maximum travel of the actuator (i.e. the bar is exceeding the possible travel).

**Attention:** The display does not reflect the selected closing direction of the actuator!

The actuator may be moved to any position by shifting the arrow and pressing 'Send'. Thus the valve has to be moved by the actuator to closed position. When this is reached, proved by visual examination at the valve, confirm by 'OK' to store the found value to the actuator's permanent memory.

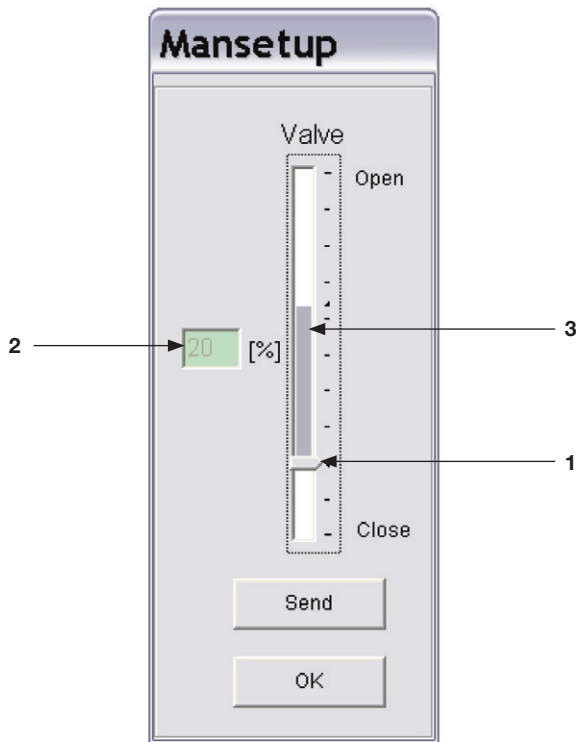

Fig. 18

### 6.5.3 Diagnostics

This function requires connection to an operational AEL6 actuator. Several sets of data about the recent status and function of the actuator are being read out and displayed. Additionally there is an indication about the recent working status of the actuator in the bottom right corner.

#### Counting values

At each starting of the actuator, totalling is done of:

- Number of starts.
- Number of starts at critical temperature.
- Total operation time of the actuator, in hours.
- Running time of the motor, in minutes.
- Running time of the motor at critical temperature, in seconds.

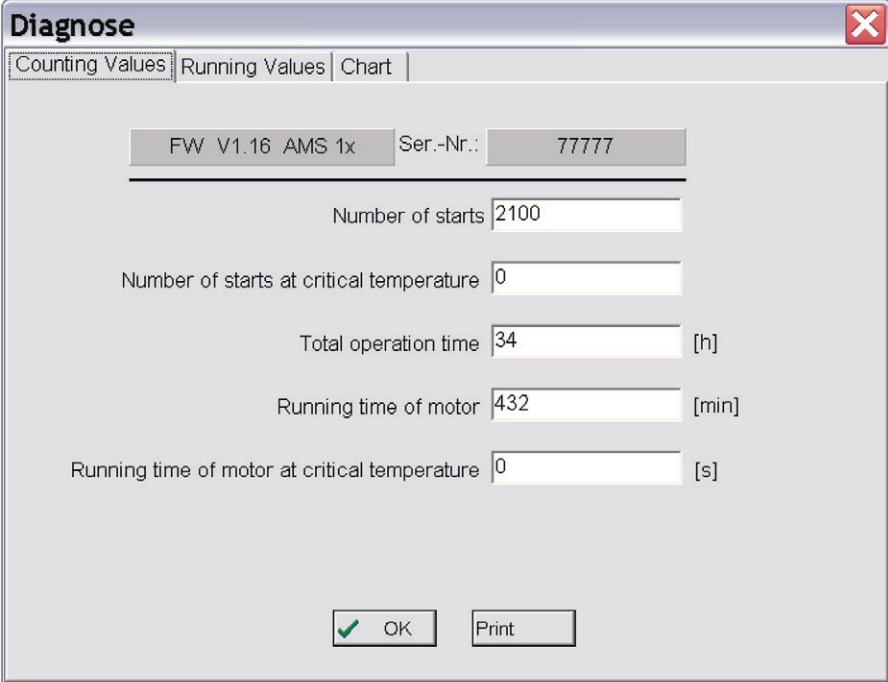

The screenshot shows a software window titled "Diagnose" with a close button (X) in the top right corner. The window has three tabs: "Counting Values" (selected), "Running Values", and "Chart". Below the tabs, there is a header section with "FW V1.16 AMS 1x" and "Ser.-Nr.: 77777". A horizontal line separates this header from the data fields. The data fields are as follows:

Number of starts	2100
Number of starts at critical temperature	0
Total operation time	34 [h]
Running time of motor	432 [min]
Running time of motor at critical temperature	0 [s]

At the bottom of the window, there are two buttons: "OK" (with a green checkmark icon) and "Print".

Fig. 19

## Counting values

At each starting of the actuator the values for applied set value:

- Reached feedback value,
- Generated motor torque,
- Temperature inside the actuator.

are measured and stored to a sequential memory of 11 data sets. They may be displayed as a table or as a graph.

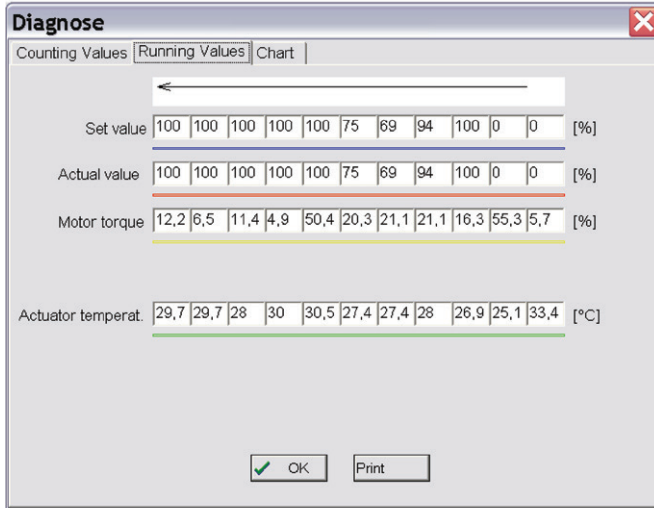

Fig. 20



Fig. 21

## 6.5.4 Monitor

This function requires connection to an operational AEL6 actuator. It is used for on-line monitoring of function and performance of control, and for optimising the optionally available integrated process controller.

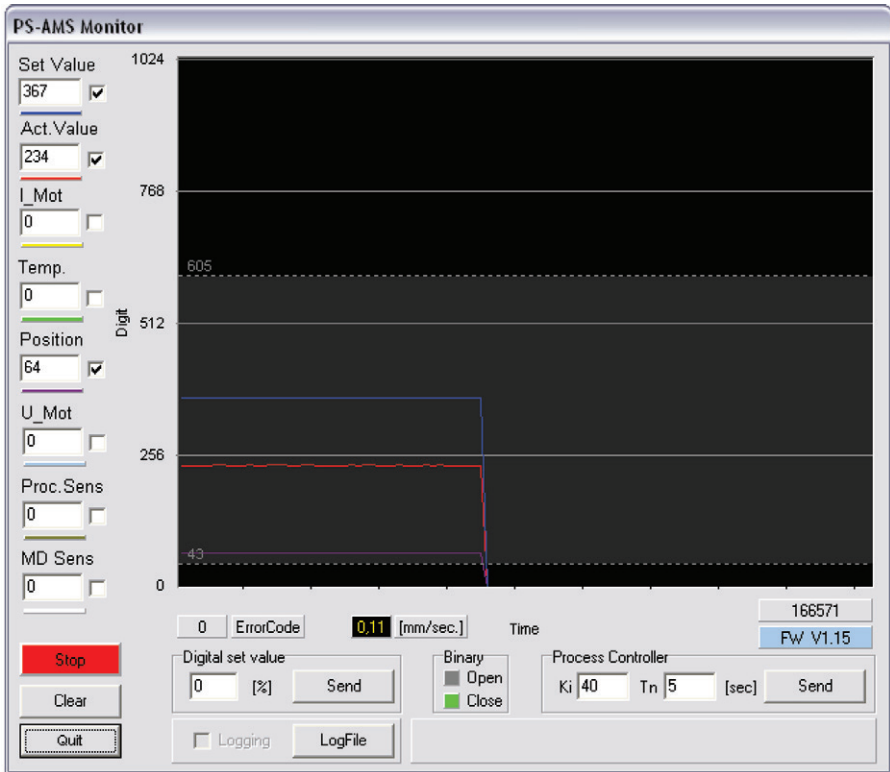
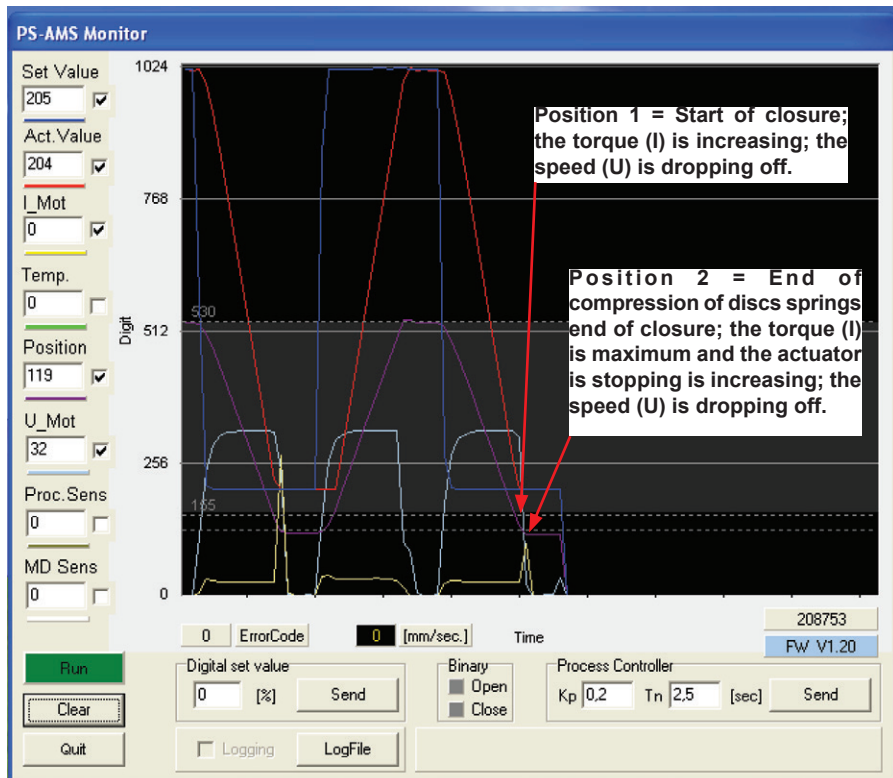

Fig. 22

The display shows non-standardised basic data; for example, a value of 4 mA out of a range of 20 mA (= 1023 digits) will be displayed as 205 digits. Displaying the value may be selected by marking the respective click box, the graph screen is erased by 'Clear'. 'Stop' holds the currently visible curve. 'Quit' closes the monitor.

- **Set Value:** shows the actually applied value.
- **Feedback Value:** momentary value as calculated from the actuator position and readable at the terminals for Active Feedback.
- **I\_Mot:** Current that is supplied to the motor by the electronics. This is approximately proportional to the output torque of the motor.
- **Temp:** temperature inside the actuator.
- **Position:** momentary travel position of the actuator.
- **U\_Mot:** Voltage that is supplied to the motor by the electronics. This is approximately proportional to the motor speed.
- **Proc. Sens:** Feedback from the (optionally available) integrated process sensor.

**Fig. 23 Example** with a DN25 SPIRA-TROL on an open and close cycle: I = Torque U = Speed



- **MD Sens:** Momentary value of the torque sensor at PSQ-AMS (optional).
- **ErrorCode** displays the status of the actuator as per the error codes below.

Error code	Description of status
<b>Working condition</b>	0 Normal operation
	1 Actuator doing auto-commissioning
	2 Actuator not commissioned to the valve
<b>Peripheral errors</b>	3 Set value error
	4 Torque error
	5 Fail-safe action is started
	6 Set value error of the process sensor
	11 Undervoltage at supply
	12 Position passed over
13 Position nor reached	
<b>Errors in the actuator</b>	7 Mechanical / positioning error
	8 Critical / maximum temperature reached
	9 Electronics error / CRC
	10 Limit of wear reached

- **[mm/sec.]** shows the actual output speed.
- **Digital Set Value** can be altered and sent from here if 'Digital Set Value' is activated under 'Input and Output Signals'. However, the value here is only temporarily used and not permanently stored to the actuator!
- **LogFile** allows readout of the displayed curves as sets of values in an unformatted log-file. Pressing 'LogFile' prompts creating a file <filename>.log in any directory. Ticking the box in front of 'Logging' writes sets of values to that file each 500 msec, in a form as shown below. Writing is done as long as 'Logging' is active. This data may be used for further evaluation.

*PS Automation GmbH AMS1x LogFile ID 166571; FW V1.15; 16:31:38; 22.02.2007*

*Time;Setvalue;Actualvalue;I\_Mot;Temp;Pos;U\_Mot;PR\_Ist;MD\_Sens;ErrNo.*

*16:31:40;367;464;4;632;221;338;0;726;0*

*16:31:41;367;463;4;632;221;338;0;727;0*

*16:31:41;367;463;4;633;221;339;0;727;0*

*16:31:42;367;463;4;632;221;339;0;726;0*

*16:31:42;367;463;4;631;221;339;0;727;0*

*16:31:43;367;457;4;632;125;144;0;728;0*

- **Binary** indicates the presence of a binary signal for driving Open or Closed by showing one of the two fields in green.
- **Process controller:** If the optionally available process controller is activated the values for TN and KP may be entered and adjusted here. 'Send' writes the values to the actuator. TN is delay time and KP is proportional amplification factor.

**Firmware version** and **Serial number** of the actuator are indicated in the lower right corner.

## 6.6 Help

Displays the version and issue date of the software PSCS in use.

---

## 7. Fault finding

---

In case no communication is possible with the actuator, please check:

- Supply voltage has to be connected and switched on.
- The plugs of the communication cable must be firmly plugged in the sockets at both actuator and computer.
- The correct COM-port has to be selected via the software, and it must not be assigned to their devices. At laptop PCs, COM 1 is often used internally for a touch panel. Furthermore some installed software (e.g. for synchronising with a handheld) may block some ports. See 'Interface' under 'File' in the chapter 'Menu Structure'.

