

ABV21i and ABV40i
Air Actuated Boiler Blowdown Valves
Installation and Maintenance Instructions

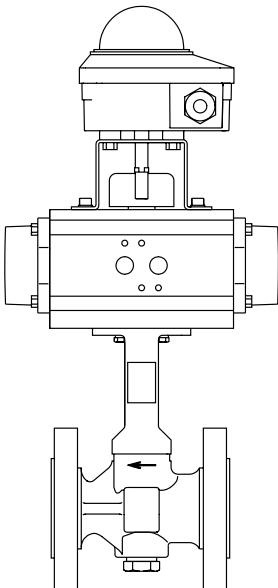

1. Safety information
2. General product information
3. Installation
4. Commissioning
5. Operation
6. Maintenance
7. Spare parts
8. Fault finding

1. Safety information

Safe operation of this product can only be guaranteed if it is properly installed, commissioned, used and maintained by qualified personnel (see Section 1.11) in compliance with the operating instructions. General installation and safety instructions for pipeline and plant construction, as well as the proper use of tools and safety equipment must also be complied with.

WARNINGS

Before commencing any dismantling work on a boiler, depressurise, drain, and vent the boiler to atmosphere.

Pipelines must be adequately isolated, depressurised, and drained. Isolation valves must be turned on and off gradually to avoid system shocks.

Ball valves can trap pressurised media in the body, so make sure there is no pressure to the valve body, or any pressure remaining in the body, before loosening or removing the flange bolts. The actuator must be isolated both pneumatically and electrically before any maintenance is carried out.

Do not attempt to service the actuator without first consulting the Installation and Maintenance Instructions, as the end caps contain springs under pressure. Failure to follow the instructions could result in injury. The actuator must be vented before dismantling.

If the valve should seize in the partly open position, the springs in the actuator will still be partly compressed, and will consequently be storing a large amount of energy, which could cause injury if released suddenly. If there is any possibility that this is the case follow the instructions given in the 'Maintenance' section of this booklet - 'Dismantling a seized valve assembly'.

Maximum supply pressure	8 bar g	(116 psi g)
-------------------------	---------	-------------

1.1 Intended use

Referring to the Installation and Maintenance Instructions, name-plate and Technical Information Sheet, check that the product is suitable for the intended use / application. The products listed below comply with the requirements of the European Pressure Equipment Directive 97/23/EC and carry the  mark when so required. The products fall within the following Pressure Equipment Directive categories:

Product	Group 1 Gases	Group 2 Gases	Group 1 Liquids	Group 2 Liquids		
ABV21i and ABV40i	DN25	SEP	SEP	SEP		
	DN32	2	SEP	SEP		
	DN40 - DN50	ABV21i	2	1	SEP	SEP
		ABV40i	2	1	2	SEP
	DN65	2	1	2	SEP	

- i) The products have been specifically designed for use on steam, compressed air, water and other industrial fluids that are in Group 2 of the above mentioned Pressure Equipment Directive. They can also be used on methane gas, propane gas, oxygen gas and hydrocarbons which are in Group 1 of the Pressure Equipment Directive. The products' use on other fluids may be possible but, if this is contemplated, Spirax Sarco should be contacted to confirm the suitability of the product for the application being considered.

-
- ii) Check material suitability, pressure and temperature and their maximum and minimum values. If the maximum operating limits of the product are lower than those of the system in which it is being fitted, or if malfunction of the product could result in a dangerous overpressure or overtemperature occurrence, ensure a safety device is included in the system to prevent such over-limit situations.
 - iii) Determine the correct installation situation and direction of fluid flow.
 - iv) Spirax Sarco products are not intended to withstand external stresses that may be induced by any system to which they are fitted. It is the responsibility of the installer to consider these stresses and take adequate precautions to minimise them.
 - v) Remove protection covers from all connections and protective film from all name-plates, where appropriate, before installation on steam or other high temperature applications.

1.2 Access

Ensure safe access and if necessary a safe working platform (suitably guarded) before attempting to work on the product. Arrange suitable lifting gear if required.

1.3 Lighting

Ensure adequate lighting, particularly where detailed or intricate work is required.

1.4 Hazardous liquids or gases in the pipeline

Consider what is in the pipeline or what may have been in the pipeline at some previous time. Consider: flammable materials, substances hazardous to health, extremes of temperature.

1.5 Hazardous environment around the product

Consider: explosion risk areas, lack of oxygen (e.g. tanks, pits), dangerous gases, extremes of temperature, hot surfaces, fire hazard (e.g. during welding), excessive noise, moving machinery.

1.6 The system

Consider the effect on the complete system of the work proposed. Will any proposed action (e.g. closing isolation valves, electrical isolation) put any other part of the system or any personnel at risk?

Dangers might include isolation of vents or protective devices or the rendering ineffective of controls or alarms. Ensure isolation valves are turned on and off in a gradual way to avoid system shocks.

1.7 Pressure systems

Ensure that any pressure is isolated and safely vented to atmospheric pressure. Consider double isolation (double block and bleed) and the locking or labelling of closed valves. Do not assume that the system has depressurised even when the pressure gauge indicates zero.

1.8 Temperature

Allow time for temperature to normalise after isolation to avoid danger of burns.

1.9 Tools and consumables

Before starting work ensure that you have suitable tools and/or consumables available. Use only genuine Spirax Sarco replacement parts.

1.10 Protective clothing

Consider whether you and/or others in the vicinity require any protective clothing to protect against the hazards of, for example, chemicals, high/low temperature, radiation, noise, falling objects, and dangers to eyes and face.

1.11 Permits to work

All work must be carried out or be supervised by a suitably competent person. Installation and operating personnel should be trained in the correct use of the product according to the Installation and Maintenance Instructions.

Where a formal 'permit to work' system is in force it must be complied with. Where there is no such system, it is recommended that a responsible person should know what work is going on and, where necessary, arrange to have an assistant whose primary responsibility is safety.

Post 'warning notices' if necessary.

1.12 Handling

Manual handling of large and/or heavy products may present a risk of injury. Lifting, pushing, pulling, carrying or supporting a load by bodily force can cause injury particularly to the back. You are advised to assess the risks taking into account the task, the individual, the load and the working environment and use the appropriate handling method depending on the circumstances of the work being done.

1.13 Residual hazards

In normal use the external surface of the product may be very hot. If used at the maximum permitted operating conditions the surface temperature of these products may reach temperatures of 260°C (500°F).

These products are not self-draining. Take due care when dismantling or removing them from an installation (refer to 'Maintenance instructions').

1.14 Freezing

Provision must be made to protect products which are not self-draining against frost damage in environments where they may be exposed to temperatures below freezing point.

1.15 Safety information - Product specific

Hydraulic locking

Ball valves are prone to lock-up when used on certain heating / cooling applications where both steam and liquid will pass through the valve. This is caused by liquid trapped in the ball during closure being heated to create a high hydraulic pressure inside the ball cavity. To prevent this, during manufacture, a minute hole is drilled in the ball, so, that in the closed position, any excess pressure will be relieved. Spirax Sarco ball valves for these applications are clearly marked to allow the valve to be correctly installed, such that, when closed, the hole is facing the steam source.

1.16 Disposal

Unless otherwise stated in the Installation and Maintenance Instructions, this product is recyclable and no ecological hazard is anticipated with its disposal providing due care is taken.

1.17 Returning products

Customers and stockists are reminded that under EC Health, Safety and Environment Law, when returning products to Spirax Sarco they must provide information on any hazards and the precautions to be taken due to contamination residues or mechanical damage which may present a health, safety or environmental risk. This information must be provided in writing including Health and Safety data sheets relating to any substances identified as hazardous or potentially hazardous.

— 2. General product information —

2.1 General description

The Spirax Sarco ABV21i and ABV40i are one piece end entry, reduced bore ball valves having ISO mounting as standard. They are fitted with a 90° rotary spring return pneumatic actuator, and a limit switch box. They are used in conjunction with a Spirax Sarco blowdown timer to provide timed control of bottom blowdown, ensuring that the recommended boiler blowdown cycles occur with minimum heat loss, avoiding duplication or omission. The valve is suitable for a maximum pressure of 17.25 bar g @ 208°C (250 psi g at 406°F).

A NAMUR (VDI/VDE 3845) solenoid valve is also required, and may be selected from the Spirax Sarco MV range. Alternatively, an air supply (maximum pressure DN25 8 bar (116 psi), DN32 to DN65 6 bar (87 psi)) may be connected directly to the actuator port 'A' (1/4" BSP), for applications where it is necessary to install the solenoid valve remote from the actuator. A standard 1/4" BSP 3-way solenoid valve may also be used.

ISO mounting

The integral ISO body mounting allows the valve to be automated without losing seal integrity, as the body does not require disassembly.

2.2 Product availability

Valve type	Valve size	Actuator	Switch box
ABV21i and ABV40i	DN25	BVA315S/14	LSB31
	DN32	BVA320S/14	LSB31
	DN40	BVA325S/14	LSB31
	DN50	BVA325S/14	LSB31
	DN65	BVA330S/14	LSB31

2.3 Actuator

The actuator uses a rack and pinion system with a quarter-turn operation. A position indicator is fitted to the top of the pinion shaft, below the switch box. BVA actuators are factory lubricated, and do not require a lubricated air supply. The air must, however, be dry and clean. Any other non-corrosive gas can be used as the operating medium.

2.4 Switch box

LSB limit switch boxes are normally used for indicating valve open or valve closed position. They also allow switching points to be adjustable over the full range of actuators. There is an open / closed valve position indicator mounted at the end of the switch box axis, at the top of the cover. LSB's include a stainless steel linkage kit for direct mounting to BVA300 series actuators.

Fig. 1 ABV21i

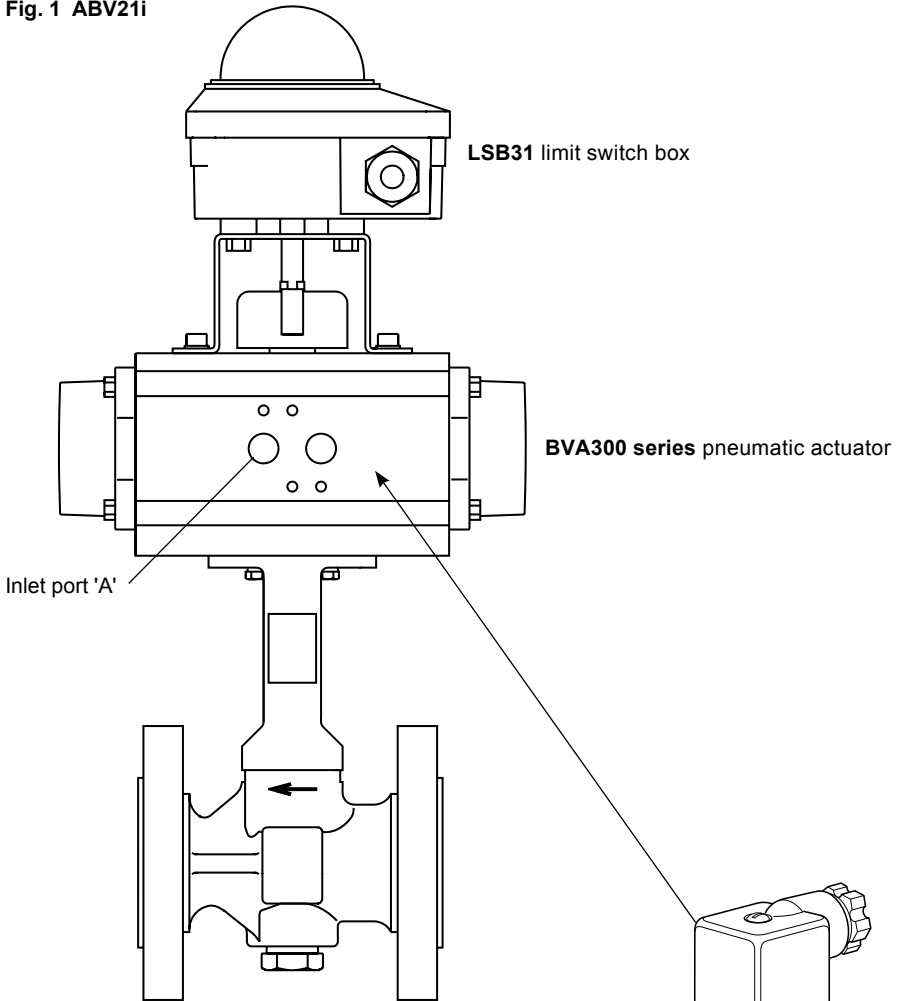
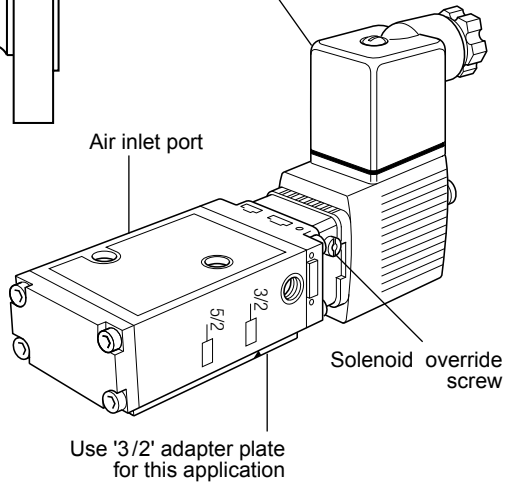
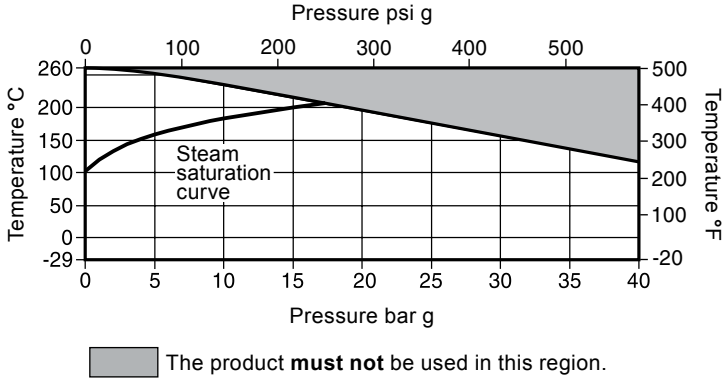

Fig. 2
Solenoid valve
MV11 / MV12 / MV11 / MV12
General view



2.5 ABV21i - Pressure / temperature limits



Valve

Body design conditions		PN40
PMA	Maximum allowable pressure	40 bar g @ 120°C (580 bar g @ 248°F)
TMA	Maximum allowable temperature	260°C @ 0 bar g (500°F @ 0 psi g)
	Minimum allowable temperature	-29°C (-20°F)
PMO	Maximum operating pressure for saturated steam service	17.25 bar g @ 208°C (250 psi g at 406°F)
TMO	Maximum operating temperature	260°C @ 0 bar g (500°F @ 0 psi g)
	Minimum operating temperature	-29°C (-20°F)
Note: For lower operating temperatures consult Spirax Sarco		
ΔPMX	Maximum differential pressure is limited to the PMO	
	Designed for a maximum cold hydraulic test pressure of:	60 bar g (870 psi g)

Actuator

Maximum ambient temperature	80°C (176°F)
Minimum ambient temperature	0°C (32°F)
Maximum air supply pressure	8 bar g (116 psi g)
Minimum air supply pressure is dependant on operating conditions	

MV series solenoid

Maximum ambient temperature	50°C (122°F)
Minimum ambient temperature	0°C (32°F)

2.6 ABV40i - Pressure / temperature limits

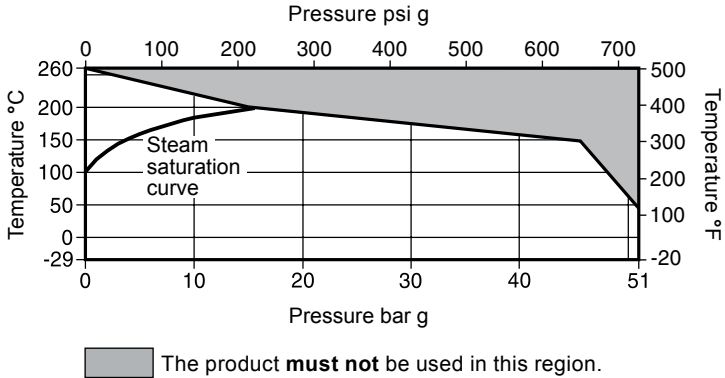

Valve

Body design conditions		ASME 300
PMA	Maximum allowable pressure	51 bar g @ 38°C (739 bar g @ 100°F)
TMA	Maximum allowable temperature	260°C @ 0 bar g (500°F @ 0 psi g)
Minimum allowable temperature		-29°C (-20°F)
PMO	Maximum operating pressure for saturated steam service	17.25 bar g @ 208°C (250 psi g at 406°F)
TMO	Maximum operating temperature	260°C @ 0 bar g (500°F @ 0 psi g)
Minimum operating temperature		-29°C (-20°F)
Note: For lower operating temperatures consult Spirax Sarco		
ΔPMX Maximum differential pressure is limited to the PMO		
Designed for a maximum cold hydraulic test pressure of:		76.5 bar g (1 109 psi g)

Actuator

Maximum ambient temperature	80°C	(176°F)
Minimum ambient temperature	0°C	(32°F)
Maximum air supply pressure	8 bar g	(116 psi g)
Minimum air supply pressure is dependant on operating conditions		

MV series solenoid

Maximum ambient temperature	50°C	(122°F)
Minimum ambient temperature	0°C	(32°F)

3. Installation

Note: Before actioning any installation read the 'Safety information' in Section 1.

Although the valve has great structural integrity, severe misalignment and/or the pulling effect of incorrect pipe length will have a detrimental effect on the valve and must be avoided. Particular attention should be paid to correct pipe alignment such that the inlet pipework and valve are all on the same axis.

Wherever practicable, valves should be installed where there is adequate space available so that they can be conveniently operated and maintained.

Before installing a valve, check to ensure that size, pressure rating, materials of construction, end connections, etc. are suitable for the service conditions of the particular application. Care must be taken to ensure that all dirt which may have accumulated in the valve during storage is removed before installation, maintain cleanliness during installation since the introduction of dirt can result in damage to the valve seats and operating mechanism. To minimise the danger of abrasive particles damaging the seats, pipeline strainers should be fitted upstream of the valves. Install the valve with the actuator uppermost. The preferred position is with the stem vertical. The air supply to the solenoid valve/actuator must be in 10 mm (3/8") minimum diameter pipe. The air inlet connection is 1/4" BSP (G).

Table 1 Maximum air pressure

Valve size	Actuator	Maximum air pressure
DN25	BVA315S/14	8 bar g (116 psi g)
DN32	BVA320S/14	8 bar g (116 psi g)
DN40 and DN50	BVA325S/14	8 bar g (116 psi g)
DN65	BVA330S/14	8 bar g (116 psi g)

3.1 To fit an MV type solenoid assembly to the valve actuator:

- Turn the spring loaded solenoid override screw anticlockwise to release it for normal working.
- Fit the screwed location pin from the MV kit in the top centre position above the actuator ports (see Figure 3). Ensure the pin is screwed far enough into the actuator to allow a good seal to be made i.e. that it is not holding the solenoid away from the actuator.
- Use the '3/2' adapter plate supplied with the solenoid assembly. Discard the '5/2' plate.
Note: Earlier versions used a double-sided plate. For this type, align the arrow on the plate with the '3/2' on the valve assembly.
- Fit the solenoid assembly to the actuator using the 2 screws provided in the kit. **Do not overtighten the screws** as this could distort the plastic body and prevent proper working.
- Connect the air supply to port 1 (1/4" BSP). Note that port 3 is blanked for this application. The unmarked port near the override screw is not connected in this application.

The solenoid override is operated by using a screwdriver to push the spring loaded plastic screw inwards and turning it clockwise to lock it in the 'override' position. This bypasses the solenoid and allows the ABV to be operated without an electricity supply. The screw is released by turning it anticlockwise.

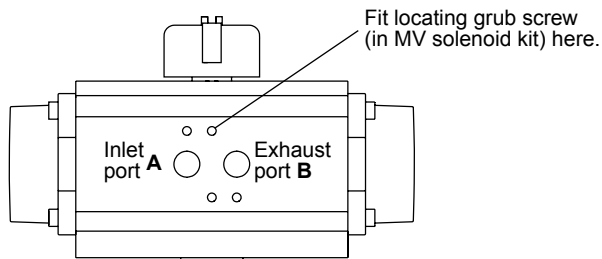

Fig. 3
BVA actuator
showing inlet and
exhaust ports

3.2 Switch box wiring and terminal connections are shown in Figure 4

The switch box is supplied with Pg 11 cable gland.
The switches are suitable for 10 A, 250 Vac operation.

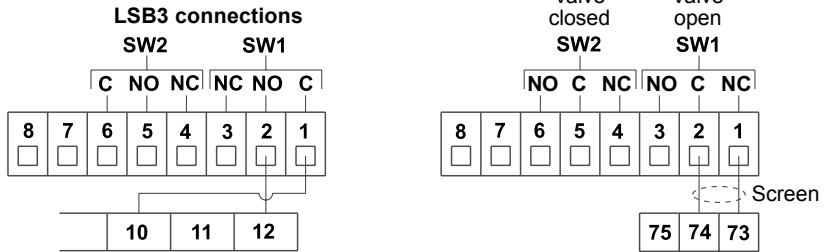

Fig. 4

BT1000 connections

BT1050 BB switch connections

For the wiring of alternative versions of the LSB switch refer to IM-P372-27

4. Commissioning

After installation or maintenance ensure that the system is fully functioning. Carry out tests on any alarms or protective devices.

5. Operation

The air supply is switched on by the solenoid valve, causing two pistons in the actuator to move apart against spring pressure.

Racks attached to the pistons turn the actuator pinion and shaft, opening the valve fully.

On release of the air pressure, the springs return the valve to the closed position.

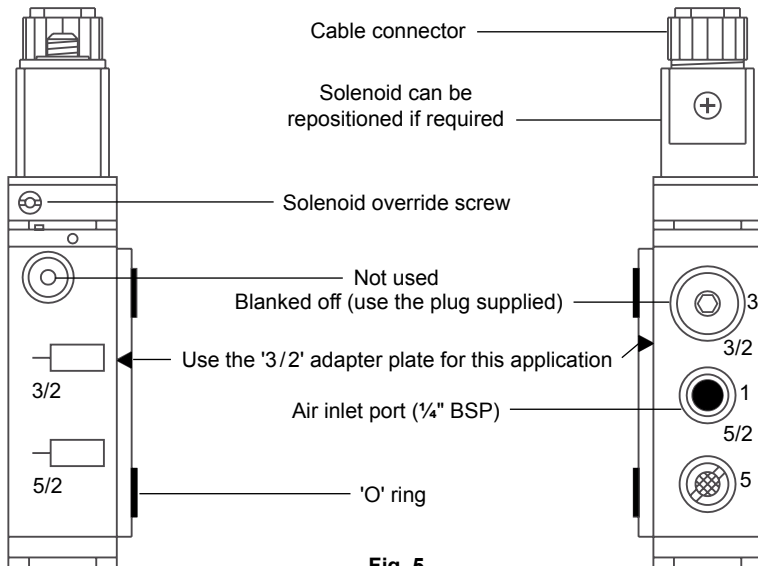

Fig. 5

6. Maintenance

Actuator

Note: Before actioning any maintenance programme read the 'Safety information' in Section 1.

6.1 General

Periodically check that all fasteners remain tight.

No routine maintenance is required, as the actuator is supplied with sufficient lubrication for a normal working life. Depending on the severity of actuator operating conditions, periodic replacement of the 'O' rings may be required. Spares are available - see Section 7.

6.2 Preventive maintenance

6.2.1 We recommend a periodic inspection to check the actuator function.

6.2.2 Actuators must be operated at least once every six months.

6.2.3 Replace the 'O' rings, guides and washers if necessary.

6.3 Reasons for parts repair and replacement

Repair or replace the actuator components as soon as leakage is detected through the upper 'O' ring (16) or lower 'O' ring (7) of the pinion, through the piston 'O' ring (8) or through the 'O' rings (11) of the end caps.

6.4 Disassembly and reassembly of the actuator

6.4.1 Precautions before disassembly:

- Isolate and test the air and electrical supplies before working on the actuator.
- Disconnect the actuator and its accessories from the air tubing and electrical wiring.
- Disassemble the solenoid from the actuator.
- Disassemble the actuator from the valve and/or from its couplings.

6.4.2 Disassembly

Once the precautions prior to the disassembly have been taken, follow the next steps:

- Disassemble the end caps (4) of the actuator by untightening the external bolts (20).
Please note - With spring return actuators there is no inherent danger during this operation, as the fastening bolts for the caps are designed with adequate length.
- Unfasten the nuts (24) in order to remove the levelling screws (23).
- Turn the pinion (3) anticlockwise to disengage the pistons (2) in normally closed actuators and clockwise in normally open ones. Remove the pistons from the cylinder.
- Disassemble the position indicator (21, 22 and 27), the slip washer (13), the soft pinion washer (15) and the metallic pinion washer (14) from the upper side.
- Disassemble the pinion (3) from the lower part of the body (1) of the actuator. To do this operation, disassemble the upper pinion bearing (10) and the stop (12) through the inside of the body.
- Clean all the parts of the actuator.
- Examine all parts in order to inspect for wear.
Important: Carefully examine the inside of the cylinder.
- If everything is in good condition, fit the new 'O' rings, bushings, slide guides and washers included in the Spirax Sarco BVA300 series maintenance kit before reassembling the actuator - see Section 6.4.3.
- Lubricate the parts of the actuator with Molykote B 2-2 plus grease. Apply a thin layer of grease on the 'O' rings (7, 8 and 16).

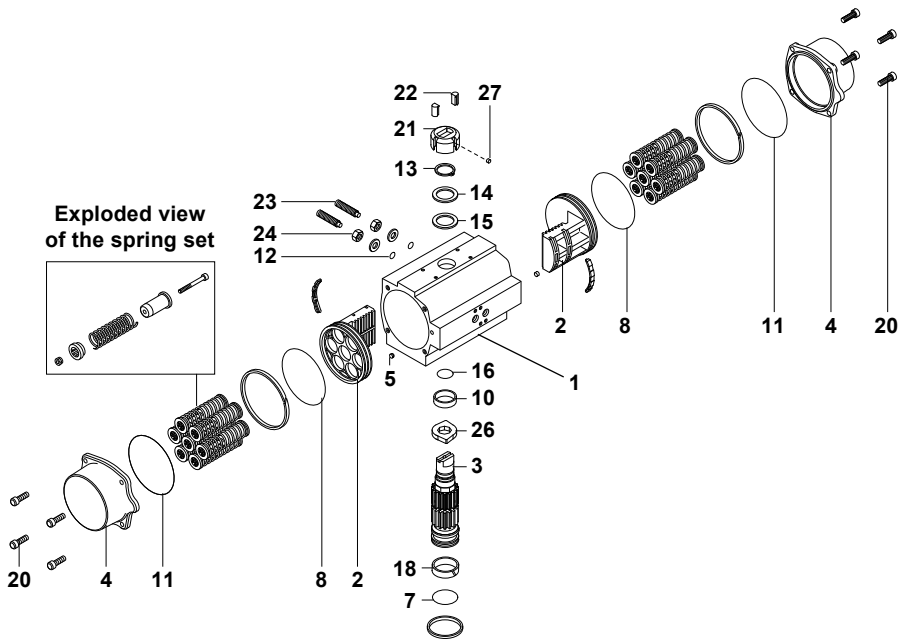

Fig. 6 BVA300 series shown

6.4.3 Reassembly

After disassembly, and the inspection and lubrication of the relevant parts, proceed to reassemble them following the sequence below:

- Correctly assemble all the parts included in the Spirax Sarco BVA300 series maintenance kit.
Note: lubricate where stated in Section 6.4.2.
- Place the pinion (3) in the body (1) from underneath. Once the pinion appears through the inside of the body, assemble the pinion stop (12) in its correct position and also the upper pinion bearing (10).
- Place the soft pinion washer (15), the metallic pinion washer (14), the slip washer (13) and the position indicator (21, 22 and 27) in the upper part of the pinion.
- Assemble both pistons, checking that they engage at the same time when turning the pinion (3) clockwise for normally closed actuators and anticlockwise for normally open actuators.
- Assemble the actuator end caps (4) tighten the bolts (20) in sequence. Check that the open and closed positions coincide with the position indicated in the upper part of the pinion (see Figure 6).

Important: Once assembled, operate the actuator a few times and recommission - see Section 4.

Valve

Note: Before actioning any maintenance programme observe the 'Safety information' in Section 1.

6.5 Maintenance

As with all mechanical devices, regular maintenance is the most efficient means of ensuring continued operational efficiency. Regular scheduled inspection of all valves is essential especially on valves which are operated only occasionally.

6.6 General maintenance

Remove the complete flanged valve from the pipeline. The complete body assembly can then be removed and new parts fitted. **Please note:** A special tool, that is only available from Spirax Sarco, is required in order to remove the insert (2) - See Section 7, Available spares. When the seats have been replaced and the valve has been reassembled it is recommended that the following tests are conducted before commissioning back into service:

- Cold hydraulic test to the ABV21i body at 60 bar g (870 psi g), and the ABV40i body at 76.5 bar g (1109 psi g).
- Seat leakage test using compressed air at 7 bar g.

6.7 How to replace the seats (5):

- Remove the body as described in Section 6.2.
- With the body removed, remove the seats (5) and 'O' ring (6).
- Fit new seats (5) pushing them into the body chamber.
- Insert a new 'O' ring (6) replace the ball valve insert (2) and tighten to the recommended torque - See Table 1.

6.8 How to replace the stem seals (9 and 10):

- Remove the body as described in Section 6.2.
- Remove the nut (15).
- Replace the stem seals (9 and 10).
- Insert a new 'O' ring (6) replace the ball valve insert (2) and tighten to the recommended torque - See Table 1.

6.9 Reassembly

Reassemble in reverse order to instructions given above. The stem nut (15) and the ball valve insert (2) should be tightened to the recommended torques shown in Table 1.

Table 1 Recommended tightening torques

Item no.	Part	Size	N m	lbf ft
2	Insert	DN25 and DN32	108 - 135	80 - 100
		DN40	135 - 160	100 - 120
		DN50	215 - 245	160 - 180
		DN65	245 - 270	180 - 200
15	Nut	DN25	17.5 - 20.3	13 - 15
		DN32, DN40, DN50 and DN65	34 - 40	25 - 30

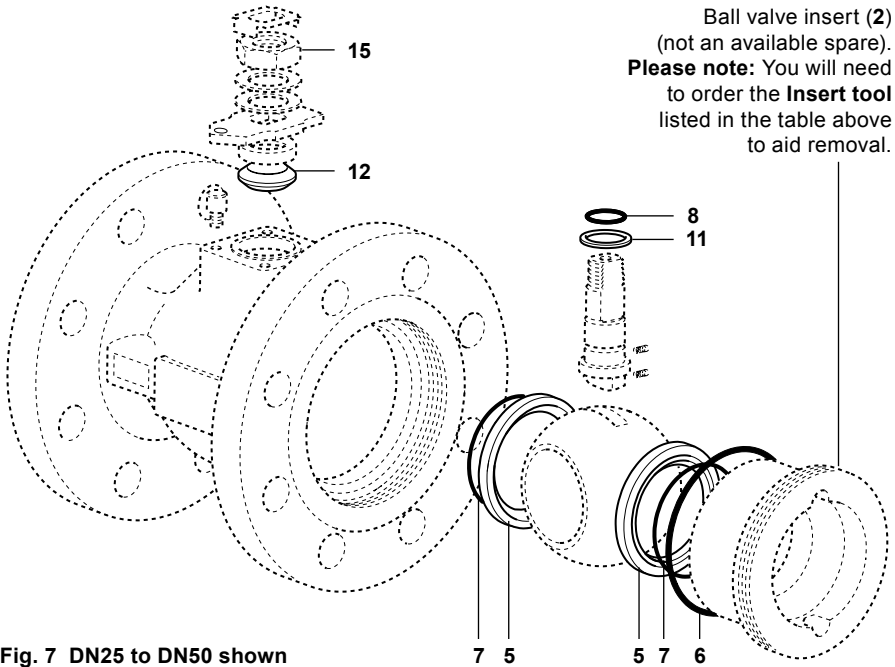

6.10 Testing:

- Ensure that the stem can rotate freely, without undue friction.
- Carry out seat leakage and body hydraulic testing as appropriate:

Seat leakage test at	6 bar g	(87 psi g)	(air under water)
Cold hydraulic test at	78 bar g	(1 131 psi g)	(Class 300)

6.11 Assembly:

- Refit actuator/bracket assembly ensuring that the valve is fully closed before attempting to locate the drive adapter.
- Connect an air supply and check that the valve opens and closes correctly and fully.

6.12 Switch box

To adjust switch box microswitch settings:-

- Switch off power supply to switch box.
- Remove switch box cover.
- Remove indicator disc.
- Turn the cam to the required position.
- Replace indicator disc - ensure it is aligned correctly.
- Replace cover and switch on air and power correctly.

7. Spare parts

Actuator

A valve spares kit is available, which includes all seals and gaskets and a valve ball. Spare valve stems are also available. An actuator spares kit is available. State actuator type on order. No spares are available for the switch box.

Caution: The vent hole in the ball must be on the upstream side of the valve.

Note: Before actioning any maintenance programme observe the 'Safety information' in Section 1.

Any parts replacement must be implemented with original Spirax Sarco spare parts, or any warranty implied or expressed is null and void.

The manufacturer will not be responsible for any actuator dysfunction, if original Spirax Sarco parts have not been used.

7.1 Spare parts for the BVA300S/14

The available spare parts for the BVA300S/14 are listed opposite. No other parts are available as spares.

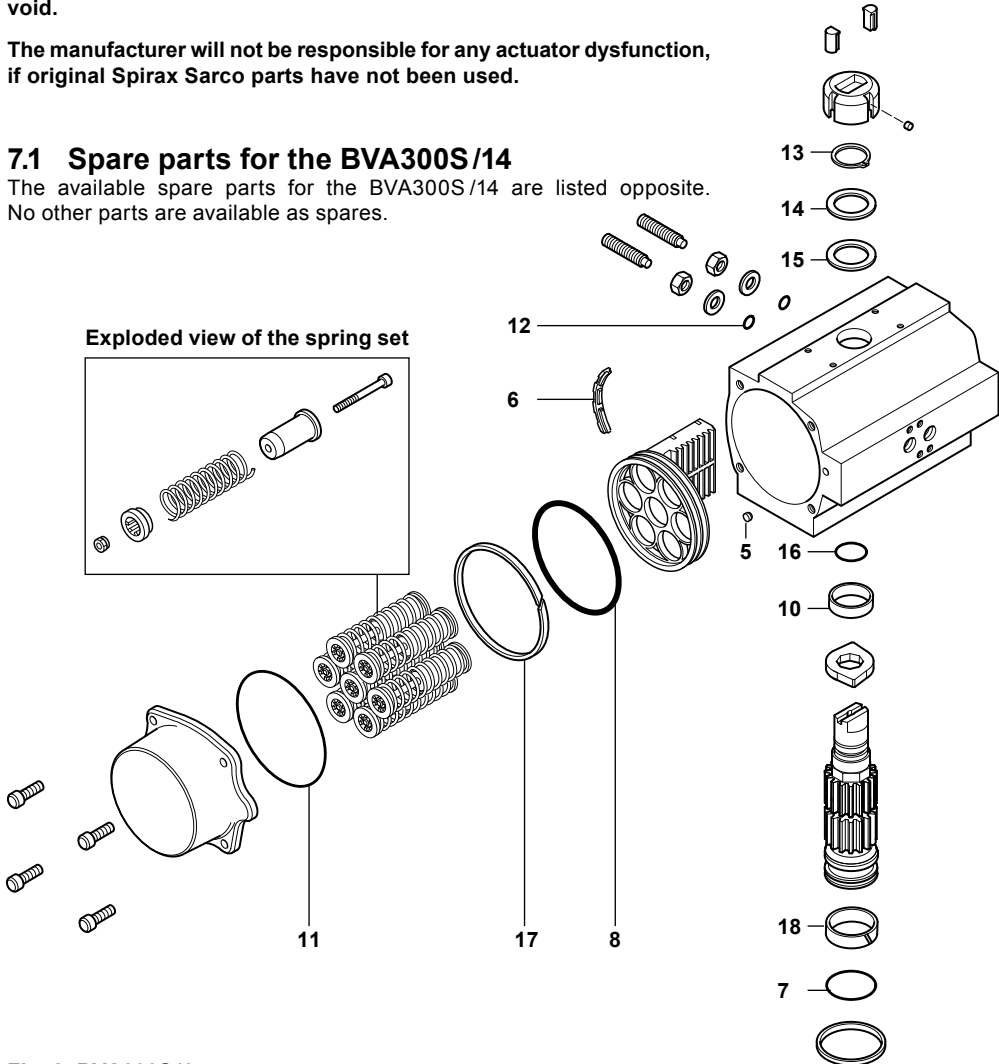
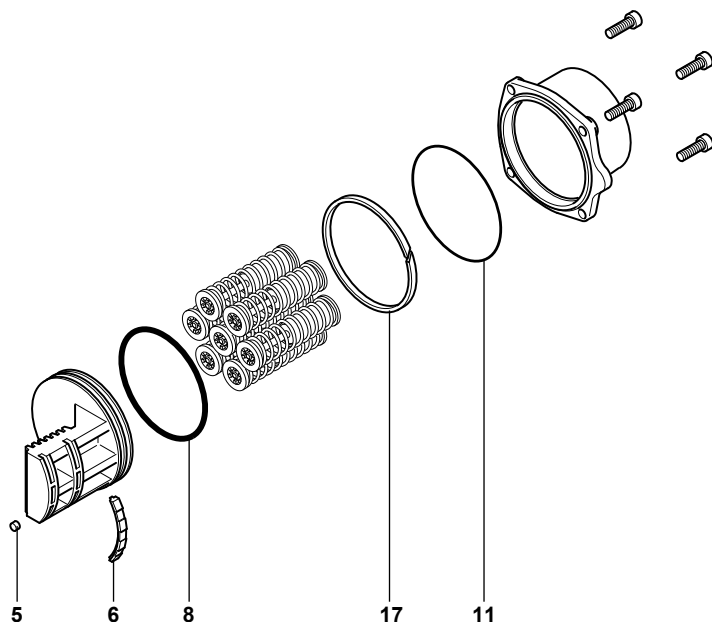

Fig. 8 BVA300S/14 spare parts



Spare parts

The spare parts available are detailed below. No other parts are supplied as spares.

Available spares

BVA300 series maintenance kit	'O' rings set (NBR)	7, 8, 11, 12, 16
	Pinion washers	13, 14, 15
	Others	5, 6, 10, 17, 18

How to order spares

Always order spares by using the description given in the column headed 'Available spares' and state the nomenclature of the pneumatic actuator that they are intended for.

Note: all the spares mentioned above are sold together in one spare part kit.

Example: 1 - BVA300 series maintenance kit with 'O' rings in NBR for a Spirax Sarco BVA320S/14 pneumatic actuator.

Valve

7.2 DN25 to DN50 Spare parts

The spare parts available are shown in solid outline. Parts drawn in broken line are not supplied as spares.

Available spares

Seats, insert 'O' ring and stem seals	5, 6, 9, 10
Insert tool - Required to aid the removal of the ball valve insert (2)	Not shown

Please note: Spare parts are common for both the ABV21i and ABV40i.

Caution: The ball must be installed with the vent hole on the upstream side of the valve.

How to order spares

Always order spares by using the description given in the column headed 'Available spares' and state the size and type of ball valve.

Example: 1 set of seats, insert 'O' ring and stem seals for a Spirax Sarco DN50 ABV21i boiler blowdown valve.

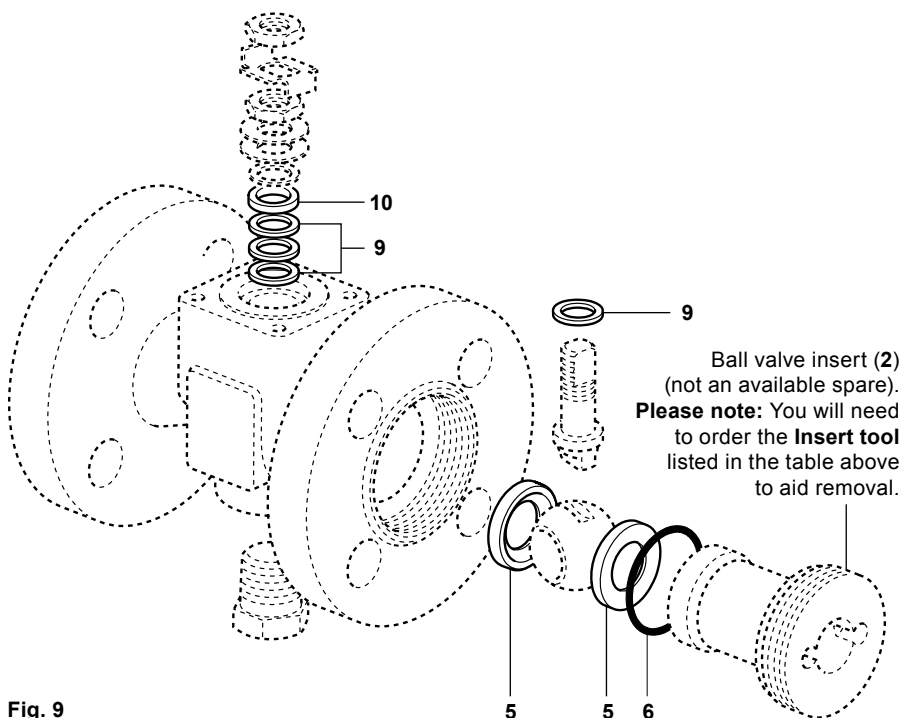

7.3 DN65 Spare parts

The spare parts available are shown in solid outline. Parts drawn in broken line are not supplied as spares.

Available spares

Seats, insert 'O' ring, seat 'O' ring, stem 'O' ring, lower stem seals and upper stem packing	5, 6, 7, 8, 11, 12
Insert tool - Required to aid the removal of the ball valve insert (2)	Not shown

Please note: Spare parts are common for both the ABV21i and ABV40i.

Caution: The ball must be installed with the vent hole on the upstream side of the valve.

How to order spares

Always order spares by using the description given in the column headed 'Available spares' and state the size and type of ball valve.

Example: 1 set of seats, insert 'O' ring, seat 'O' ring, stem 'O' ring, lower stem seals and upper stem packing for a Spirax Sarco DN50 ABV40i boiler lowdown valve.

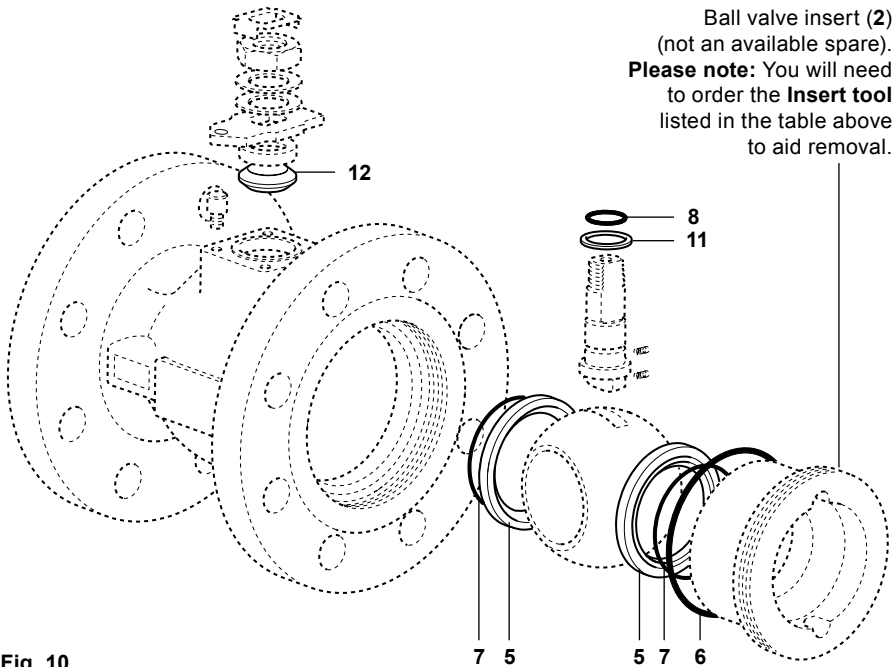

Fig. 10

8. Fault finding

Before dismantling the actuator, consult the instructions given below:

8.1 Actuator with solenoid valve

A If the actuator does not function check that:

1. The valve is free to rotate.
2. The actuator is of the correct size.
3. The speed control screws, if fitted, are loose (if screws are tightened all the way the actuator will not operate).
4. The correct voltage is supplied to the solenoid (the valve coil is tagged with the correct voltage).
5. Sufficient compressed air is available at the solenoid valve.

B If the proper voltage and air pressure have been verified and the valve is free to move proceed as follows:

1. Apply the correct voltage to the solenoid valve. Check for a clicking sound.
2. If no sound is detected:
 - i) Carefully unscrew the solenoid and solenoid stem from the block.
 - ii) Re-apply voltage and observe the solenoid plunger. If it does not retract replace the solenoid valve.
3. If the solenoid functions, remove both it and the mounting block for a bench test. Connect with a minimum 3 bar g air supply and correct voltage. Switch it on and off and check the air flow. Air should flow out of only one outlet port when the solenoid is energised. (Slight backpressure may be required to shift the valve spool. This may be generated by obstructing the outlet port).

C If the actuator functions but exhibits leak or power loss accompanied by leakage proceed as follows:

1. Check the voltage. It must be within 10% of the specified voltage.
2. Check the compressed air supply. Ensure that no intense pressure drops occur as the unit is cycled. Loss of pressure can cause incomplete shifting of the spool valve in the block or at one of the piston seals of the actuator. A leaking piston seal will usually leak on either cycle. On spring return actuators, piston seal leakage will show at port B on the air manifold flange. A leaking spool valve will require replacing. Leaking piston seals can be cured by replacing the 'O' rings with new ones.

8.2 Actuator without a solenoid valve.

For actuators without a solenoid valve, (or those where the solenoid valve and mounting block are working correctly), remove the actuator from the valve, disassemble and check the following:

1. Make sure all porting is clear of obstructions.
2. Make certain the actuator is lubricated and that there is no solidified grease between the pinion and piston racks. If solidified grease is present, clean, dry, regrease and reassemble.
3. Verify that the actuator pinion shaft and/or pistons are not seized. If seized, reassemble as per the reassembly instructions in Section 6.4.3.
4. If the unit exhibits excessive backlash, check the teeth on the piston racks for wear.
5. With spring return actuators, check for misplaced or broken springs. If springs are broken, check the body for scoring.
6. If the actuator and valve are free, reassemble the actuator and retest. If the unit still fails to operate, consult Spirax Sarco.