

25 MT Direct Acting Temperature Regulator

Safety Information

Safe operation of these products can only be guaranteed if they are properly installed, commissioned, used and maintained by qualified personnel (see Section 1.11) in compliance with the operating instructions. General installation and safety instructions for pipeline and plant construction, as well as the proper use of tools and safety equipment must also be complied with.

1.1 Intended use

Referring to the Installation and Maintenance Instructions, name-plate and Technical Information Sheet, check that the product is suitable for the intended use/application.

- i) The products have been specifically designed for use on steam, air or water/condensate. The products' use on other fluids may be possible but, if this is contemplated, Spirax Sarco should be contacted to confirm the suitability of the product for the application being considered.
- ii) Check material suitability, pressure and temperature and their maximum and minimum values. If the maximum operating limits of the product are lower than those of the system in which it is being fitted, or if malfunction of the product could result in a dangerous overpressure or overtemperature occurrence, ensure a safety device is included in the system to prevent such over-limit situations.
- iii) Determine the correct installation situation and direction of fluid flow.
- iv) Spirax Sarco products are not intended to withstand external stresses that may be induced by any system to which they are fitted. It is the responsibility of the installer to consider these stresses and take adequate precautions to minimise them.
- v) Remove protection covers from all connections and protective film from all name-plates, where appropriate, before installation on steam or other high temperature applications.

1.2 Access

Ensure safe access and if necessary a safe working platform (suitably guarded) before attempting to work on the product. Arrange suitable lifting gear if required.

1.3 Lighting

Ensure adequate lighting, particularly where detailed or intricate work is required.

1.4 Hazardous liquids or gases in the pipeline

Consider what is in the pipeline or what may have been in the pipeline at some previous time. Consider: flammable materials, substances hazardous to health, extremes of temperature.

1.5 Hazardous environment around the product

Consider: explosion risk areas, lack of oxygen (e.g. tanks, pits), dangerous gases, extremes of temperature, hot surfaces, fire hazard (e.g. during welding), excessive noise, moving machinery.

1.6 The system

Consider the effect on the complete system of the work proposed. Will any proposed action (e.g. closing isolation valves, electrical isolation) put any other part of the system or any personnel at risk?

Dangers might include isolation of vents or protective devices or the rendering ineffective of controls or alarms. Ensure isolation valves are turned on and off in a gradual way to avoid system shocks.

1.7 Pressure systems

Ensure that any pressure is isolated and safely vented to atmospheric pressure. Consider double isolation (double block and bleed) and the locking or labelling of closed valves. Do not assume that the system has depressurised even when the pressure gauge indicates zero.

1.8 Temperature

Allow time for temperature to normalise after isolation to avoid danger of burns.

1.9 Tools and consumables

Before starting work ensure that you have suitable tools and/or consumables available. Use only genuine Spirax Sarco replacement parts.

1.10 Protective clothing

Consider whether you and/or others in the vicinity require any protective clothing to protect against the hazards of, for example, chemicals, high/low temperature, radiation, noise, falling objects, and dangers to eyes and face.

1.11 Permits to work

All work must be carried out or be supervised by a suitably competent person. Installation and operating personnel should be trained in the correct use of the product according to the Installation and Maintenance Instructions.

Where a formal 'permit to work' system is in force it must be complied with. Where there is no such system, it is recommended that a responsible person should know what work is going on and, where necessary, arrange to have an assistant whose primary responsibility is safety.

Post 'warning notices' if necessary.

1.12 Handling

Manual handling of large and/or heavy products may present a risk of injury. Lifting, pushing, pulling, carrying or supporting a load by bodily force can cause injury particularly to the back. You are advised to assess the risks taking into account the task, the individual, the load and the working environment and use the appropriate handling method depending on the circumstances of the work being done.

1.13 Residual hazards

In normal use the external surface of the product may be very hot. If used at the maximum permitted operating conditions the surface temperature of some products may reach temperatures in excess of 300°C (572°F).

Many products are not self-draining. Take due care when dismantling or removing the product from an installation (refer to 'Maintenance instructions').

1.14 Freezing

Provision must be made to protect products which are not self-draining against frost damage in environments where they may be exposed to temperatures below freezing point.

1.15 Disposal

Unless otherwise stated in the Installation and Maintenance Instructions, this product is recyclable and no ecological hazard is anticipated with its disposal providing due care is taken.

1.16 Returning products

Customers and stockists are reminded that under EC Health, Safety and Environment Law, when returning products to Spirax Sarco they must provide information on any hazards and the precautions to be taken due to contamination residues or mechanical damage which may present a health, safety or environmental risk. This information must be provided in writing including Health and Safety data sheets relating to any substances identified as hazardous or potentially hazardous.

1.17 Working safely with cast iron products on steam

Cast iron products are commonly found on steam and condensate systems. If installed correctly using good steam engineering practices, it is perfectly safe. However, because of its mechanical properties, it is less forgiving compared to other materials such as SG iron or carbon steel. The following are the good engineering practices required to prevent waterhammer and ensure safe working conditions on a steam system.

Safe Handling

Cast Iron is a brittle material. If the product is dropped during installation and there is any risk of damage the product should not be used unless it is fully inspected and pressure tested by the manufacturer.

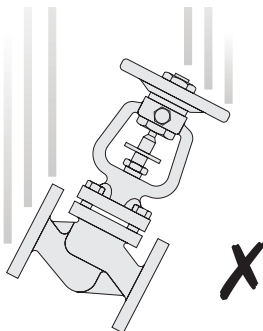

Steam Mains - Do's and Don't's:

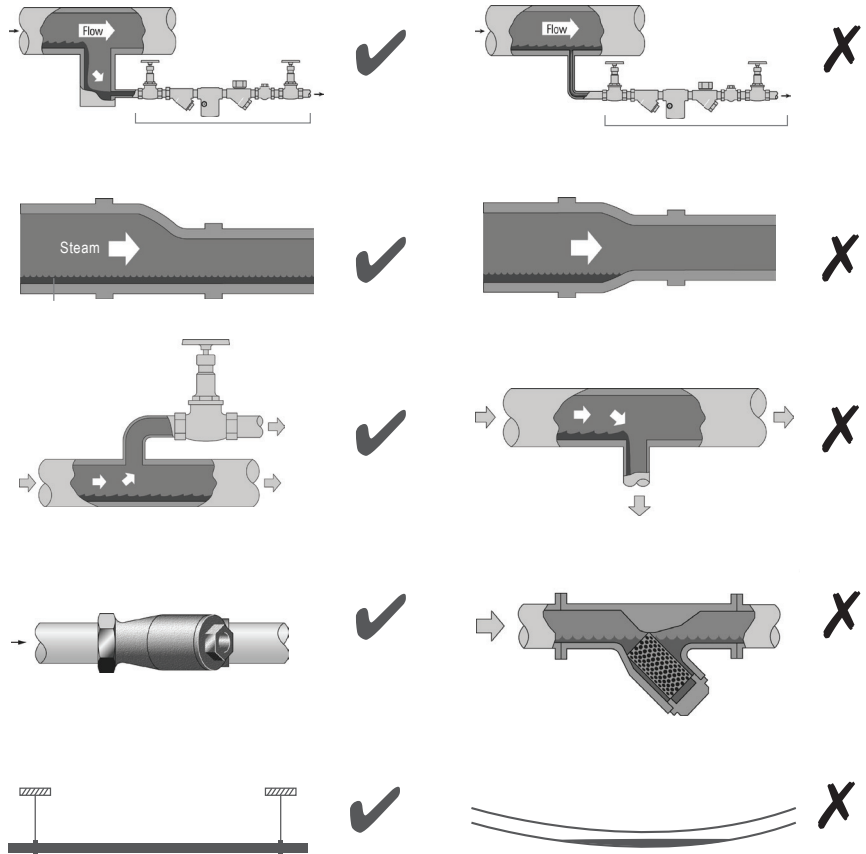

Prevention of tensile stressing

Pipe misalignment:

Installing products or re-assembling after maintenance:



Do not over tighten.
Use correct torque figures.

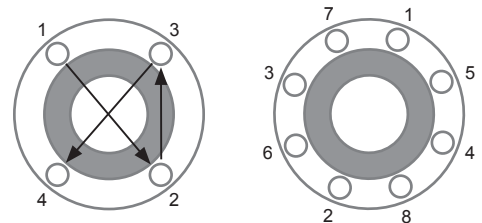

Flange bolts should be gradually tightened across diameters to ensure even load and alignment.

Prevention of water hammer

Steam trapping on steam mains:

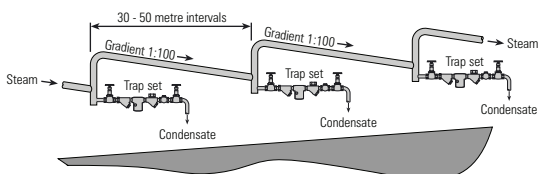

Thermal expansion:

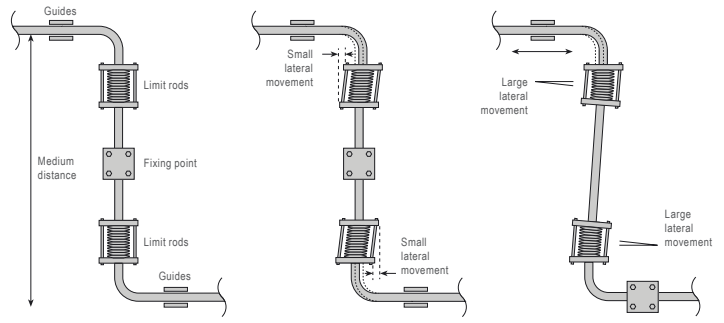
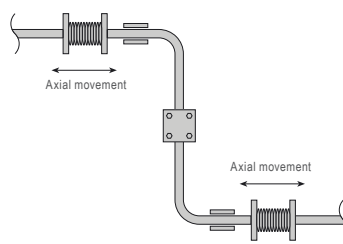
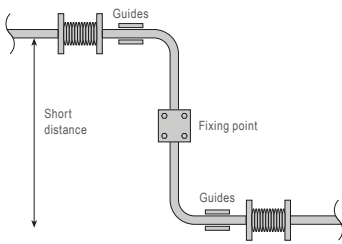

Available Types

25 MT Cast Iron

Limiting Conditions

Maximum operating pressure 250 psi (17.2 bar)

Maximum working temperature 450°F (232°C)

Temperature of bulb should not exceed 350°F (177°C)

Sizes and pipe connections

½" screwed NPT, API or BSP

Materials

No.	Part	Material	
1	"M" Body	Cast Iron	ASTM A 126 class B
2	Gasket	Asbestos	
19	"T" Body		
30	Pilot Valve Seat	Stainless Steel	AISI 303
31	Pilot Valve Head	Stainless Steel	AISI 440A
32	Adjustment Knob	Phenolic	ASTM D 700 Ty2
33	Pointer	Stainless Steel	AISI 301
34	Extension Nut	Brass	ASTM B 16
35	Case Tube	Brass	ASTM B 135 (330)
36	Retaining Nut	Brass	ASTM B 16
37	Pilot Mounting Screws	Steel	AISI 1035 Gr 5
38	Capillary Tube	Varies with style selected	
39	Bulb	Varies with style selected	

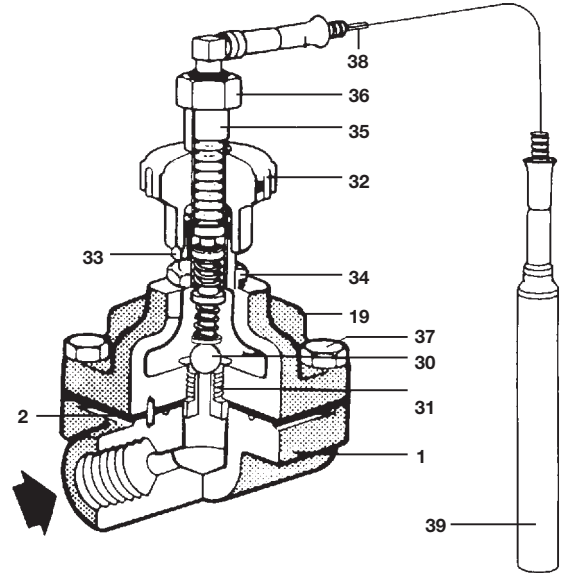

away from hot pipelines or other hot surfaces. Carefully locate the sensor bulb in the medium being heated. Insure the entire length of the bulb is immersed, with a good circulation over it. Monitor the temperature using a thermometer located close to the sensor bulb. When the bulb is used in a thermowell, use a heat conducting compound, oil or water to improve response time. If the calibrated scale on the valve is so oriented that the pointer at the set temperature is not readily seen by the operator, slacken nut 34. Rotate the entire adjustment assembly as necessary and retighten nut 34.

Temperature Ranges

60°F to 120°F	15°C to 50°C
100°F to 160°F	40°C to 70°C
120°F to 180°F	50°C to 80°C
160°F to 220°F	70°C to 105°C
200°F to 260°F	95°C to 125°C

Installation

The 25 MT is best installed in a horizontal line with the adjustment knob at the top. A strainer before the valve will protect it from line dirt. Fit the strainer on its side and insure adequate clearance for screen removal.

Use fullway pattern isolating valves and piping of adequate size to carry the steam flow. Carefully uncoil the flexible tubing avoiding sharp bends and kinks. Support the flexible tubing to protect it against mechanical damage. Keep flexible tubing

Start-up

1. First make certain that all stop valves are closed.
2. Adjust the temperature pilot to the temperature required by turning the red adjustment knob 32. Caution: Do not loosen Allen set-screw in the red temperature knob.
3. Open stop valves in the following order:
 - a. Open stop valve ahead of steam trap on steam supply line. This will insure condensate-free steam as the regulator inlet.
 - b. Open downstream stop valve.
 - c. Slowly open inlet stop valve.
4. After the system has stabilized, check thermometer temperature. Readjustment of the temperature setting knob 32 may be necessary. Note: In the event the temperature indicated on the calibrated dial does not agree with the thermometer, the temperature pilot can be recalibrated to match the thermometer.
5. Important—Retighten all pilot flange connections to insure steam tight joints.

General Inspection

While a program of planned maintenance is always to be recommended, the Spirax Sarco 25 MT will give long and trouble-free service if correctly selected, installed, and kept reasonably free of dirt and foreign matter. These are most likely to collect during installation, and later trouble can be avoided by inspecting the installation a few days after first commissioning.

1. Clean all pipeline strainers (remove screens to clean).
2. Check the main valve seat: (30).
3. Check all joints for leakage.

Inspecting and Replacing 25 MT Valve Head and Seat. (Refer to Figs)

Note: Inspecting and replacing valve head assembly can be done without removing the T body from the main valve base. However, if more convenient, the entire T body can be removed from the main base by removing the four flange screws 37.

Note: To replace the seat, the entire T body must be removed from the main valve.

1. Unscrew hexagon nut (34) and remove temperature adjustment assembly.
2. The pilot valve head assembly (E2), which includes the springs, Teflon seal, and valve head, can then be withdrawn and inspected.
3. If it is found after inspection that the head is worn, the entire assembly should be replaced. (Refer to Repair Parts List Page No. 42).
4. The pilot valve seat can be removed for inspection using a 1/2" hexagon socket wrench.
5. If the seat shows signs of wear, the seat should be replaced including a new seat gasket.

Recalibration of Temperature

The temperature adjustment dial can be recalibrated after servicing or to match the calibration of a thermometer on a particular application installed next to the temperature bulb. To recalibrate, proceed as follows:

1. The control bulb must be immersed in a temperature within the range of the calibrated dial.
2. With steam pressure on the valve, turn temperature adjustment knob (32) slowly clockwise until main valve shuts off flow of steam.
3. Turn temperature adjustment knob (32) counterclockwise slightly, just enough to start a slight flow of steam.
4. Loosen small Allen set screw in red temperature adjustment knob (32) using a 3/32" hex Allen set screw wrench and pull knob upwards off its rubber support.
5. Rotate red temperature knob until temperature on scale matches temperature reading at the control bulb, then push knob downwards over the rubber support.
6. Retighten Allen set screw. Note: No attempt should be

made to recalibrate the temperature pilot for temperatures beyond the range shown on the calibrated dial. If the temperature range is to be changed, the entire pilot assembly including the thermostatic system must be replaced. (Refer to Spirax Sarco Replacement Parts Reference Guide.)

Replacement of Thermal System.

1. Loosen hexagon nut (36) and withdraw thermostatic bellows.
2. Insert replacement system in a similar manner making certain to tighten hexagon nut (36). **Caution:** Do Not over-tighten.
3. All replacement systems are interchangeable for the same range and generally readjustment of the temperature dial is not required. However, should this be necessary, follow the instructions as described under "Recalibration of Temperature Adjustment Dial".

Temperature Pilot Spare Parts

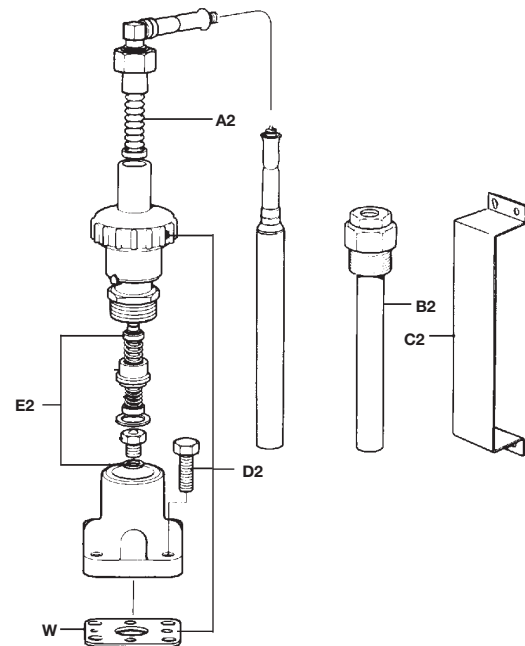

Thermal System (T1, T2, T3, T10, T11, T12)	A2
State bulb style, capillary tube length & temperature range	B2
Well (T5, T6, T7, T8, T11)	B2
State bulb style	
Wall Mounting Bracket (T9)	C2
State bulb style	
Complete Pilot Body Assembly	D2, W
Head & Seat Assembly	E2, W
Specify 15 psig or below Assembly or Standard	

Spirax Sarco Applications Engineering Department

Toll Free at:
1-800-575-0394

spirax
sarco

SPIRAX SARCO, INC. • 1150 NORTHPOINT BLVD. • BLYTHEWOOD, SC 29016
PHONE 803-714-2000 • FAX 803-714-2200