



TI-P405-37-E

EMM Issue 6 - 2023

DFG300

Automatic or Manual Actuated Boiler Blowdown Valves

Description

The DFG300 is specifically designed for the removal of suspended/ deposited solids and water from the bottom of steam boilers. The DFG300 is available in air/ water actuated and manual versions. The air/ water-actuated version can also be fitted with a standard manual hand lever. The valve is spring-to-close on power failure and the manual version can easily be upgraded to an automatic version. When used with a Spirax Sarco blowdown controller the automatic version provides timed control of blowdown, ensuring that the recommended blowdown occurs with the minimum of heat loss and avoids duplication and omissions.

The valve can be fitted with a mechanical switchbox. This can be linked to the blowdown controller or a BMS system to indicate when the valve has not closed.

A 1/4" 3-way solenoid valve is an available option that may be either directly mounted on the side of the actuator or remotely fitted.

Principal features:

- Engineered for the specific application of bottom blowdown.
- Easily upgraded from manual to automatic operation.
- Dedicated self-adjusting and self-cleaning spindle seals.
- Flow pressure assists closing.

Available types

DFG300A	DN25, DN32, DN40 and DN50 steel bodied air/ water actuated valve supplied with manual actuation lever.
DFG300M	DN25, DN32, DN40 and DN50 steel bodied manually actuated valve complete with lever.

Please note: The DFG300M can be automated.

Optional extras:

- Automatic bottom blowdown timer controller.
- 3-port solenoid valve.
- Mechanical switch (with a mounting kit included).
- Pneumatic actuator upgrade kit.

Standards

This product fully complies with the requirements of the European Pressure Equipment Directive 2014/68/EU.

Certification

This product is available with material certification to EN 10204 3.1.

Note: All certification/inspection requirements must be stated at the time of order placement.

Technical data

Solenoid valve	Supply voltage 24 Vdc, 24 Vac, 230 Vac or 110 Vac Protection rating (with connector) IP65
Mechanical switch	Supply voltage 600 Vac and 250 Vdc max Protection rating (body) IP67
Blowdown timer controller	Supply voltage 230 Vac or 115 Vac Protection rating (housing) IP40

Kvs values

Valve size	DN25	DN32	DN40	DN50
Seat diameter (mm)	25	40	40	40
Kvs values	17	20	24	30

For conversion: C_V (UK) = $K_V \times 0.963$ C_V (US) = $K_V \times 1.156$

Sizes and pipe connections

DN25, DN32, DN40 and DN50
Flanged EN 1092 PN40.

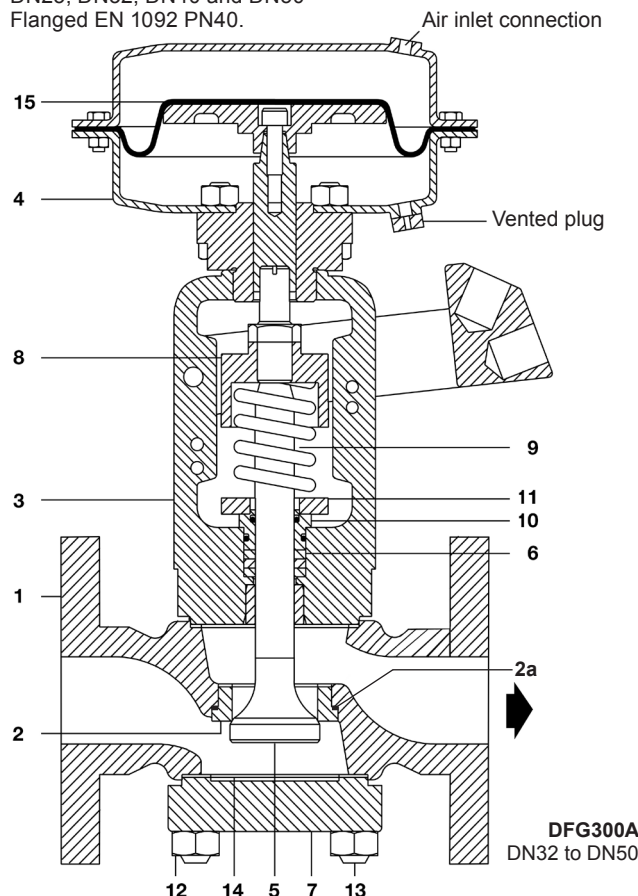

Material

N°	Part	Material	
1	Body	A or M Steel	GP 240GH
2	Valve seat	DN25 Stellite stainless steel	ASTM A479 316
	DN32-DN50	Stainless steel	BS 970 461 S29
2a	Seat gasket	Reinforced graphite	
3	Bonnet / yoke	Steel	GP 240 GH
4	Actuator housing	Pressed steel	
5	Valve head	Stellite stainless steel	ASTM A479 316
6	Gland seals	Graphite rings	
7	Bottom cover	A or M Steel	GP 240GH
8	Spring guide	Steel	Fe 37B
9	Spring	Spring steel	
10	Gland bush	Stainless steel	ASTM A479 316
11	Stuffing box flange	Steel	Fe 37B
12	Body nuts	Steel	ASTM A194 2H
13	Body studs	Steel	ASTM A193 B7
14	Body gasket	Reinforced graphite	
15	Diaphragm	Fabric reinforced nitrile rubber	

Pressure / temperature limits

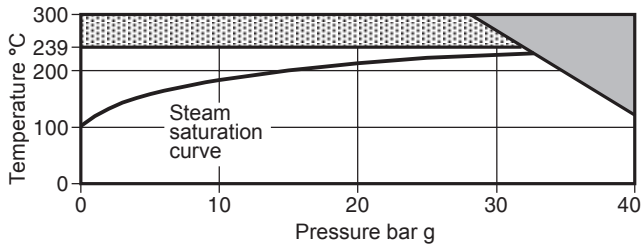

The product **must not** be used in this region.

The product should not be used in this region or beyond its operating range as damage to the internals may occur.

Body design conditions		PN40
PMA	Maximum allowable pressure	40 bar g @ 120°C
TMA	Maximum allowable temperature	300°C @ 27.5 bar
Minimum allowable temperature		0°C
PMO	Maximum operating pressure for saturated steam service	32 bar g @ 239°C
TMO	Maximum operating temperature	239°C @ 32 bar g
Ambient operating temperature range		-20°C to +90°C
Maximum operating air / water pressure		6 bar g
	Differential pressure (ΔP) across the valve	Minimum air pressure
	10 bar g	4.0 bar g
	15 bar g	4.5 bar g
Minimum air pressure	20 bar g	5.0 bar g
	25 bar g	5.5 bar g
	30 bar g	6.0 bar g
	32 bar g	6.0 bar g
Maximum temperature for a water actuated valve		70°C
Designed for a maximum cold hydraulic test pressure of		60 bar g

Dimensions / weights (approximate) in mm and kg

Size	A	B	B1	C	D	E	Weight
DN25	209	340	237	160	115	700	20
DN32	209	330	229	180	140	700	23
DN40	209	330	229	200	150	700	26
DN50	209	330	229	230	165	700	28

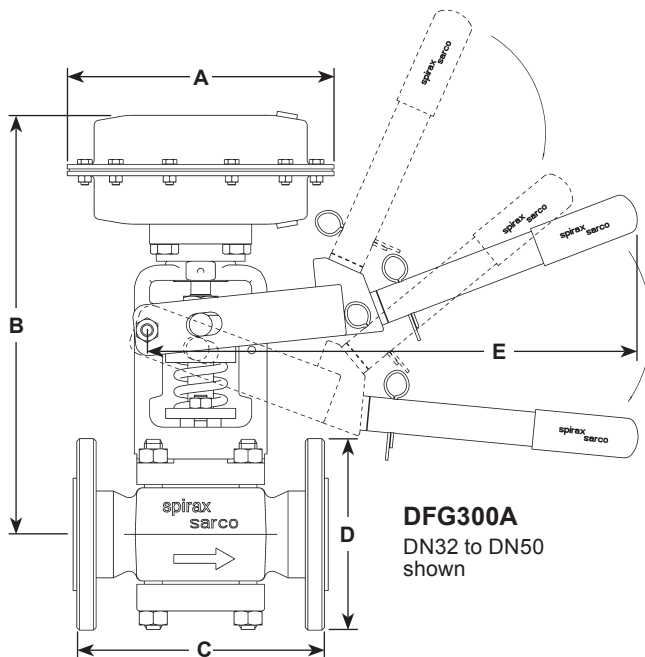

Spare parts and accessories

The spare parts available are detailed below. No other parts are supplied as spares.

Available spares (reference drawing overleaf)

Optional extras:

Stuffing box packing (3 off)	6
Actuator diaphragm	15
Gaskets kit (5 sets, seat)	2a, 14
Mechanical switch (without mounting kit)	
Manual actuation lever	

How to order spares

Always order spares by using the description given in the column headed 'Available spares' and state the type and size of the valve.

Example: 1 off Actuator diaphragm for a Spirax Sarco DN40 DFG300A automatic boiler blowdown valve.

Safety information, installation and maintenance

For full details see the Installation and Maintenance Instructions supplied with the product.

Installation note:

The valve should be fitted vertically upwards in a horizontal pipeline with the actuator above it.

Disposal:

These products are recyclable. No ecological hazard is anticipated with the disposal of these product, providing due care is taken.

How to specify

Two-port single seat valve, Spirax Sarco model DFG300A, DFG300M, suitable for bottom blowdown applications up to a maximum of 32 bar g. The valve should be air and/or hand actuated with self-adjusting and cleaning stuffing system; the valve size is to be DN50 having flanged EN 1092 PN40 connections. Valve options to be mounted on site: 3-port solenoid valve 25 Vdc and mechanical switch.

How to order

Example: 1 off DN50 Spirax Sarco DFG300A automatically actuated boiler blowdown valve having flanged EN 1092 PN40 connections.

Notes:

1. The hand lever is always included.
2. The mechanical switch can be supplied separately with a mounting kit.
3. Always state the options required at the time of order placement.

