



## BRV2S and BRV2B SG Iron Pressure Reducing Valves

### Description

The BRV2S and BRV2B are direct acting pressure reducing valves designed for applications using steam or gases such as compressed air. This range of pressure reducing valves have SG iron bodies and are available with screwed or flanged connections.

### Available types

BRV2S	Stainless steel bellows	
BRV2B	Phosphor bronze bellows	
BRV2SP	Stainless steel bellows	With external pressure sensing connection
BRV2BP	Phosphor bronze bellows	

BRV2 pressure reducing valves are supplied with one of three colour coded springs which are identified by the disc (18) located on the adjustment handwheel.

**Note:** Where control spring ranges overlap always use the lower range to give better control:

Grey	For downstream pressure control: 0.14 to 1.7 bar g
Green	For downstream pressure control: 1.40 to 4.0 bar g
Orange	For downstream pressure control: 3.50 to 8.6 bar g

### Standards

This product fully complies with the requirements of the Pressure Equipment Directive (PED).

### Certification

This product is available with a manufacturers' Typical Test Report.

**Note:** All certification/inspection requirements must be stated at the time of order placement.

### Sizes and pipe connections

½", ¾" and 1" screwed BSP (BS 21 Rp) or NPT.  
DN15, DN20 and DN25 flanged EN 1092 PN25.

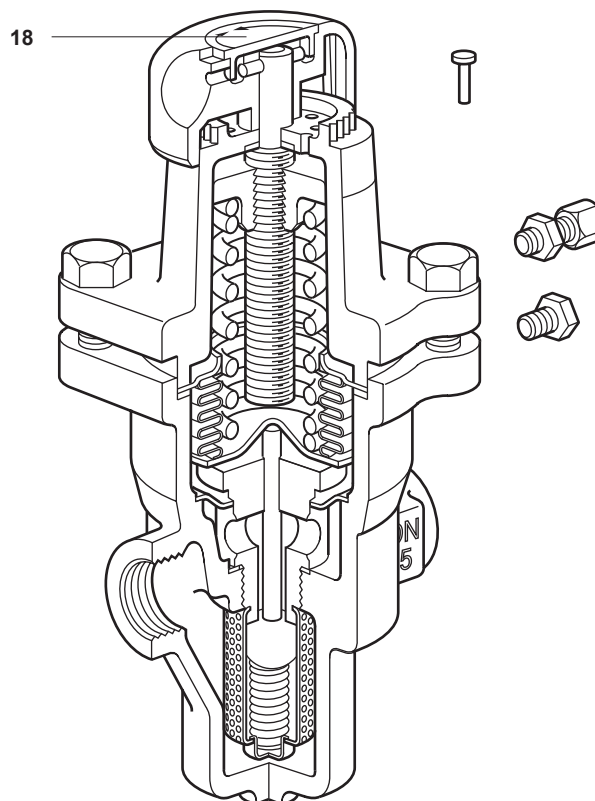

## Pressure/temperature limits

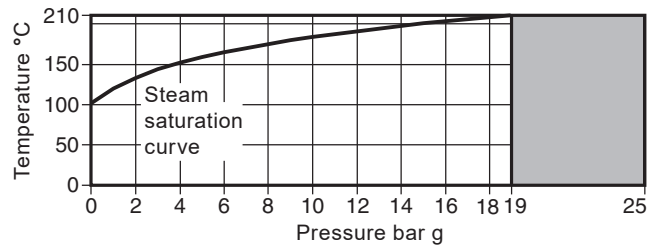

The product **must not** be used in this region.

Body design conditions	PN25
Maximum design pressure	25 bar g @ 120 °C
Maximum design temperature	210 °C @ 19 bar g
Minimum allowable temperature	-10 °C
Maximum operating pressure for saturated steam service	19 bar g @ 210 °C
Maximum operating temperature	210 °C @ 19 bar g
Minimum operating temperature	0 °C
<b>Note:</b> For lower operating temperatures consult Spirax Sarco	
Maximum downstream reduced pressure	8.6 bar g
Maximum differential pressure	19 bar
Maximum recommended turndown ratio	10:1 at maximum flow
Designed for a maximum cold hydraulic test pressure of:	38 bar g
<b>Note:</b> With internals fitted, test pressure must not exceed:	19 bar g

## Materials

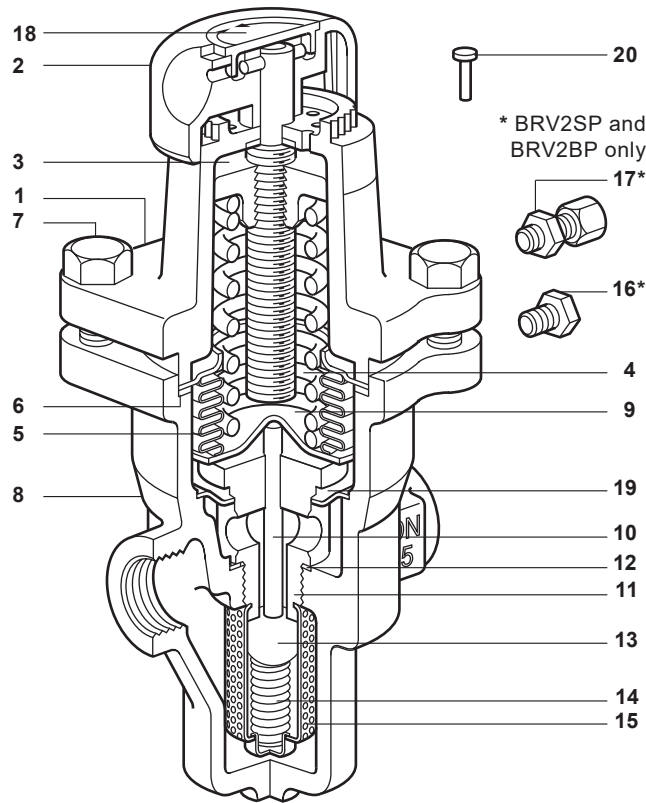

**Note:**  
Items 10, 11, 13, 14, 15 and 19 are all part of one assembly.

No.	Part	Materials	
1	Spring housing	Aluminium epoxy coated	LM 24
2	Adjustment handwheel	Polypropylene	
3	Top spring plate	Cast iron	DIN 1691 GG 20
4	Pressure adjustment spring	Silicon chrome spring steel	BS 2803 685 A55 Range 2
5	Bellows assembly	Stainless steel	316Ti/316L
		Phosphor bronze/brass	BS 2872 Cz 122
6	Bellows assembly gasket	Stainless steel reinforced exfoliated graphite	
7	Hex. bolt (M8 x 25 mm)	Steel zinc plated	BS 3692 Gr. 8.8
8	Body	SG iron	DIN 1693 GGG 40.3
10	Pushrod	Stainless steel	ASTM A276 316L
11	Valve seat	Stainless steel	BS 970 431 S29
12	Valve seat gasket	Stainless steel	BS 1449 316 S11
13	Valve	Stainless steel	AISI 420
14	Valve return spring	Stainless steel	BS 20056 316 S42
15	Strainer screen	Stainless steel	BS 1449 316 SH
16	Blanking plug	Stainless steel	BS 970 431 S29
17	Compression fitting	Brass	
18	Spring range ID disc	Polypropylene	
19	Bulkhead plate	Stainless steel	316L
20	Tamper-proof pin	Mild steel copper plated	

## Capacities for safety valve sizing

Full lift capacities for safety valve sizing purposes:	Size	DN15	DN20	DN25	For conversions: C <sub>v</sub> (UK) = K <sub>v</sub> x 0.963 C <sub>v</sub> (US) = K <sub>v</sub> x 1.156
	K <sub>vs</sub>	1.5	2.5	3.0	

## Steam and compressed air capacities

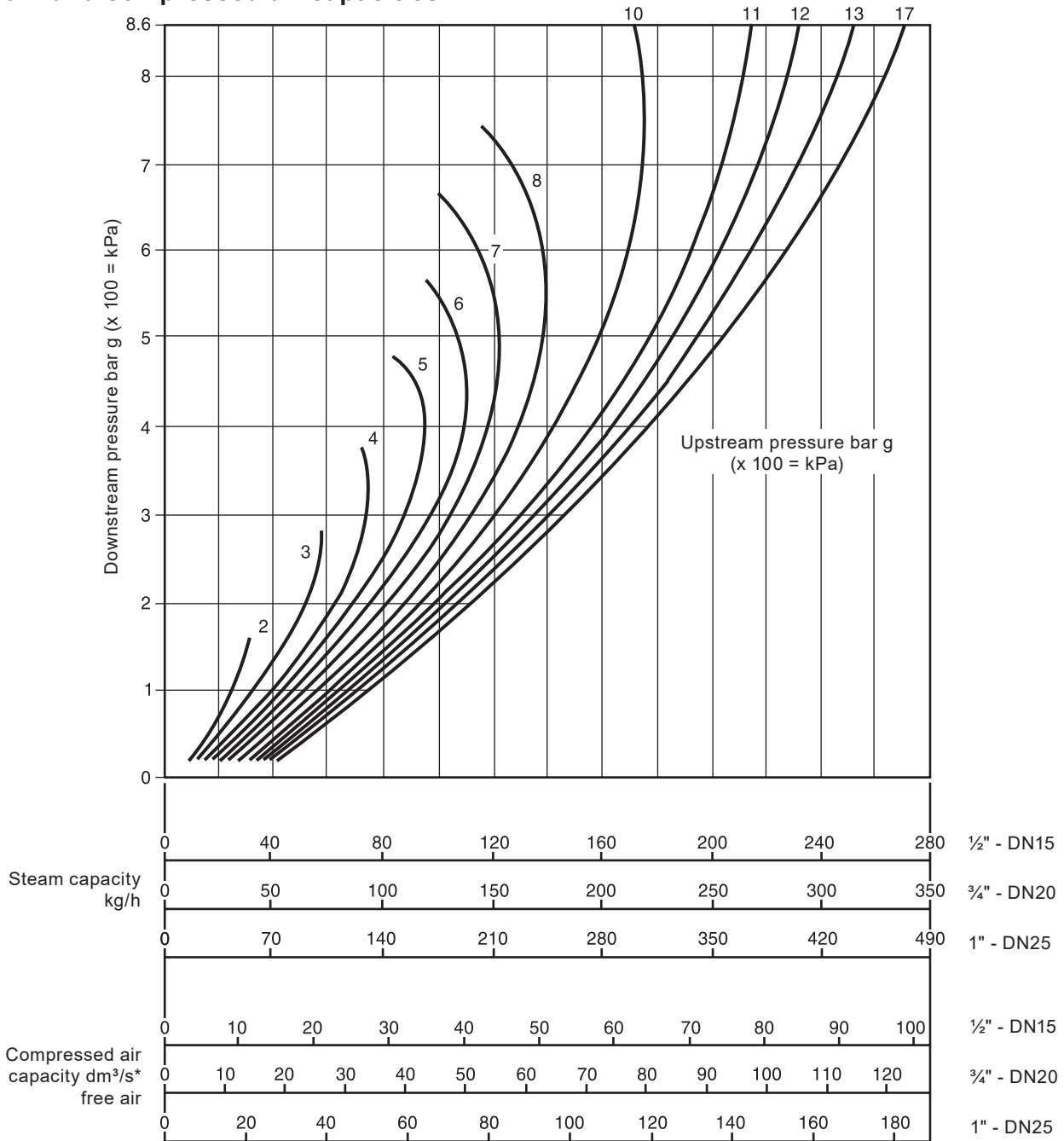

\* dm³/s = l/s, 1 l/s  $\approx$  2 c.f.m.

### How to use the chart

The curved lines labelled 2, 3, 4, 5 etc., represent upstream pressures. Downstream pressures are read along the vertical line on the left hand side of the chart.

### How to use the chart is best described by an example:-

Required, a pressure reducing valve to pass 120 kg/h reducing from 8 to 6 bar. From the downstream pressure of 6 bar on the left hand side of the chart extend out horizontally until the line meets the curved 8 bar upstream line. At this point read vertically downwards where it will be seen that a 1/2" BRV2 will be required.

## Dimensions/weights (approximate) in mm and kg

Size	A	B	C	D	E	F	Weight	
							Scr	Flg
DN15 - 1/2"	83	150	60	130	25	97	1.60	3.90
DN20 - 3/4"	96	150	60	130	25	107	1.70	4.25
DN25 - 1"	108	160	60	130	25	117	1.95	4.65

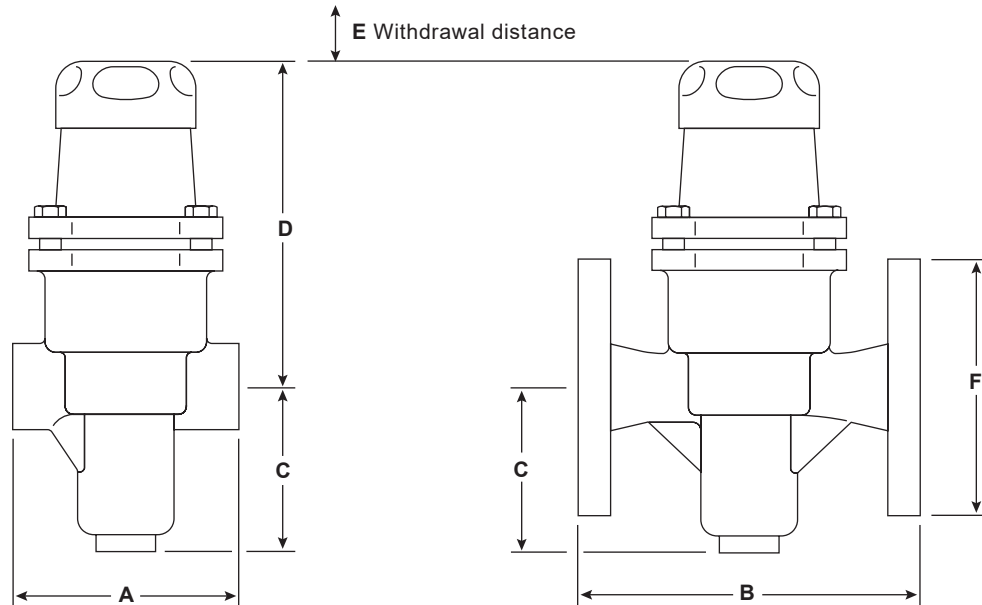

## Safety information, installation and maintenance

For full details see the Installation and Maintenance Instructions (IM-P045-10) supplied with the product.

### Installation note:

The valve should be installed in a horizontal pipeline with the direction of flow as indicated by the arrow on the valve body.

BRV2SP and BRV2BP: When external pressure sensing is used, remove the blanking plug (16) and fit the 1/8" /6 mm O/D compression fitting (17 supplied). The other end of the 6 mm sensing pipe should be connected into the downstream pipework at least 1 m downstream from the valve.

### How to order

Example: 1 off Spirax Sarco DN15 BRV2S pressure reducing valve with SG iron body flanged EN 1092 PN25, stainless steel bellows and fitted with an orange spring for downstream pressure control of 3.5 to 8.6 bar g.

## Spare parts

The spare parts available are shown in solid outline.  
Parts drawn in a grey line are not supplied as spares.

### Available spares

* Pressure adjustment spring	Grey	0.14 to 1.7 bar g	4, 18
	Green	1.40 to 4.0 bar g	4, 18
	Orange	3.50 to 8.6 bar g	4, 18
* Bellows assembly	specify type	Stainless steel or phosphor bronze	5, 6
* Spring housing hex. bolts (set of 4)			7
Valve and seat assembly			6, 11, 12, 19
* Gasket set			6, 12

\* Common to all sizes.



### How to order spares

Always order spares by using the description given in the column headed 'Available spares' and state the size, type and pressure range of the reducing valve.

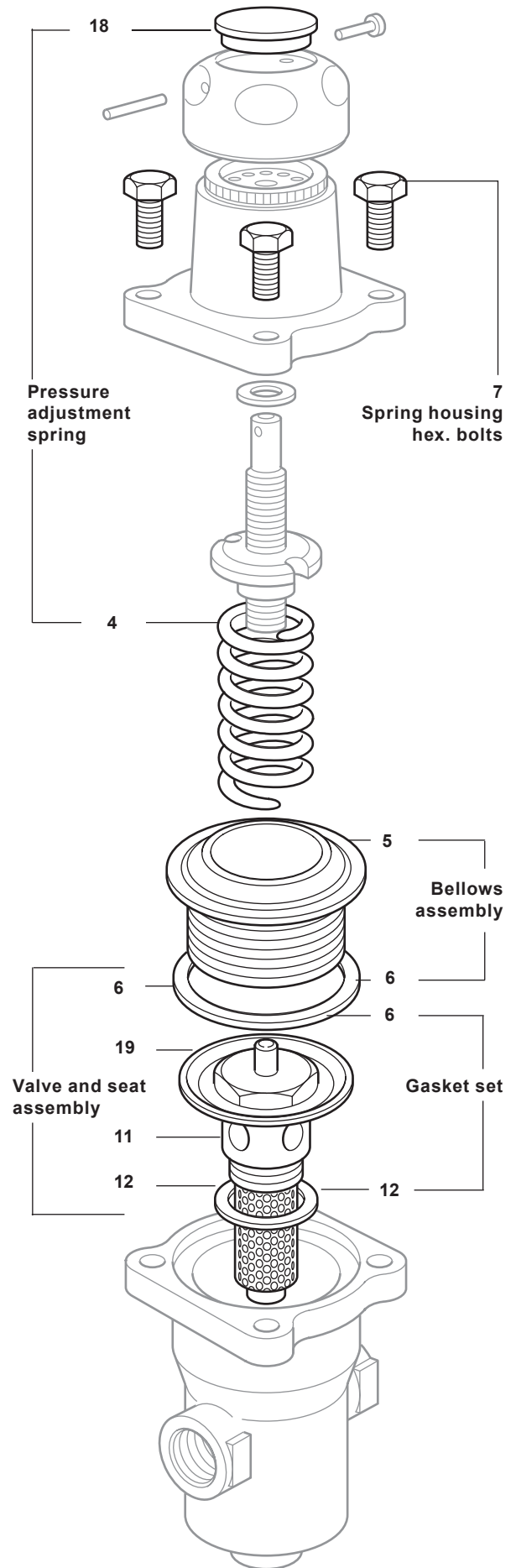
**Example:** 1 off Pressure adjustment spring (orange), having a downstream pressure range of 3.5 to 8.6 bar g for a Spirax Sarco DN15 BRV2S pressure reducing valve.



### Recommended tightening torques

Item	Part	 or 	N m
7	Hex. bolts	M8 x 25	18 - 24
11	Valve seat	32 A/F	108 - 132