



Spira-trol™ Two-port Control Valves K Series DN125 to DN300 and 6" to 12"

Description

Spira-trol™ is a range of two-port single seat globe valves with cage retained seats conforming to EN and ASME standard. These valves are available in three body materials in sizes ranging from DN125 to DN300 (6" to 12"). When used in conjunction with a pneumatic or electric linear actuator they provide characterized modulating or on/off control.

Important note: Throughout this document, reference has been made to the standard KE or KEA control valve. With the exception of trim type, the KE, KEA, KF, KFA, KL and KLA control valves are identical.

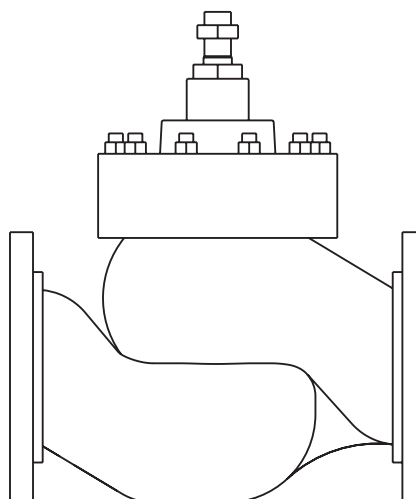

KE, KF and KL
 DN125 to DN300

KEA, KFA and KLA
 6" to 12"

Sizes and pipe connections

Valve Series	Material	PN16	PN25	PN40	JIS/KS10	JIS/KS20	ASME150	ASME300	
KE	SG Iron	DN125 - DN200			DN125				
	Carbon Steel	DN125 - DN300							
	Stainless Steel	DN125 - DN200							
KEA	Carbon Steel						6" - 12"	6" - 12"	
	Stainless Steel						6" and 8"	6" and 8"	

ASME 150 and ASME 300 are available with Flat face for use with ASME 125 and ASME 250 Flange.

Standards

Designed in accordance with EN 60534. This product fully complies with the requirements of the EU Pressure Equipment Directive/UK Pressure Equipment (Safety) Regulations and carries the mark when so required.

Certification

This product is available with certification to EN 10204 3.1. Optional seat leak test is available on request.

Note: All certification/inspection requirements must be stated at the time of order placement.

Spira-trol™ valve characteristic - options:

KE and KEA Equal percentage (E) - Suitable for most modulating process control applications providing good control at all flowrates.

KF and KFA Fast opening (F) - For on/off applications only.

KL and KLA Linear (L) - Primarily for liquid flow control where the differential pressures across the valve is constant.

Spira-trol™ valve options:

Stem sealing	PTFE chevron seals	Standard
	Graphite packing	High temperature applications
	Metal-to-metal	431 stainless steel - standard
Seating	Soft seating	Up to 170 °C (338 °F) - PTFE for Class VI shut-off (for applications like compressed air or water where there is no temperature)
		Up to 250 °C (482 °F) - PEEK for Class VI shut-off
	Hard facing	Up to 220 °C (428 °F) - PEEK (P) for Class VI shut-off 316L stainless steel with Stellite™ 6 facing - for more arduous applications
Bonnet type	Standard bonnet	
	Extended bonnet for large pipe lagging or hot/cold applications	
Trim	Standard trim	
	Low noise and anti-cavitation trim (see TI-S24-59)	

Spira-trol™ valves are compatible with the following actuators:

Electric AEL5 and AEL6 series

Pneumatic PN1000, PN2000, PN9000 and TN2000 series

Note: Reference the product specific Technical Information sheet for further details.

Materials - DN125 to DN300 (6" to 12")

Body material	Type	No.	Part	Material
Carbon steel	KE43	1	Body	Cast steel BS EN 10213 GP 240GH+N (1.0619N)
		2	Bonnet	Cast steel BS EN 10213 GP 240GH+N (1.0619N)
	KEA43	1	Body	Cast steel ASTM A216 WCB
		2	Bonnet	Cast steel ASTM A216 WCB
Stainless steel	KE63	1	Body	Stainless steel EN 10213 (1.4408)
		2	Bonnet	Stainless steel EN 10213 (1.4408)
	KEA63	1	Body	Stainless steel ASTM A351 CF8M
		2	Bonnet	Stainless steel ASTM A351 CF8M
SG iron	KE73	1	Body	SG iron EN-GJS-400-18U-LT
		2	Bonnet	SG iron EN-GJS-400-18U-LT
	KEA73	1	Body	SG iron ASTM A395
		2	Bonnet	SG iron ASTM A395

DN125
unbalanced valve

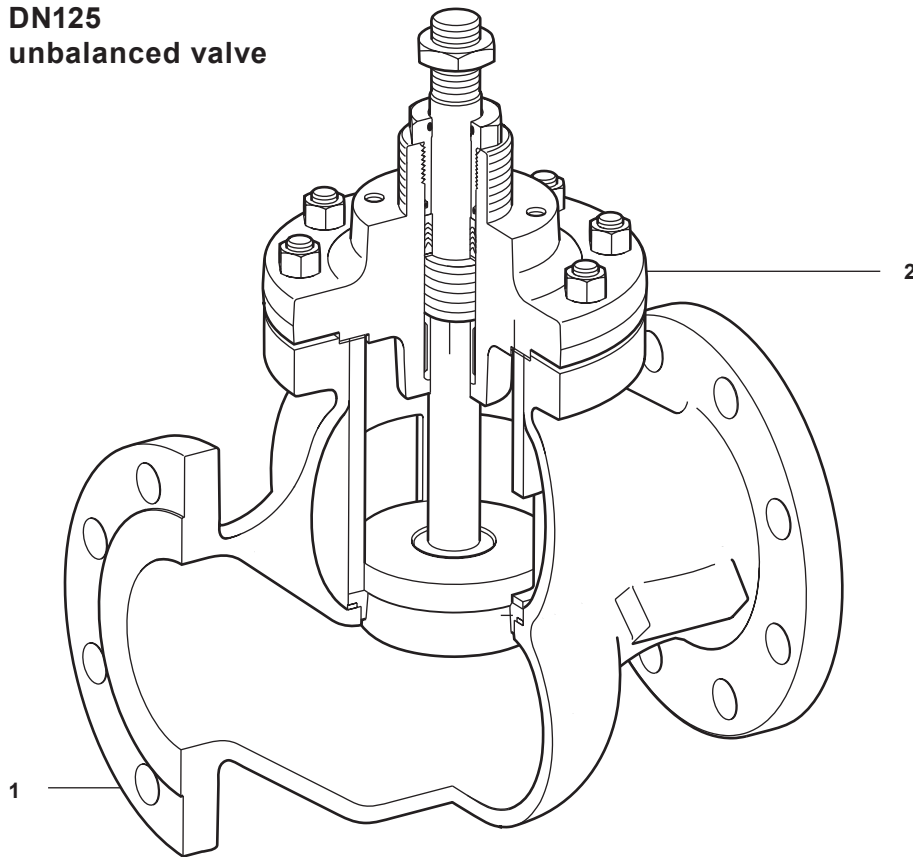

Materials - DN125 to DN300 (6" to 12") (continued)

Body material	Type	No.	Part	Material	
All versions	Plug and stem assembly	3	All others	Stainless steel	AISI 431
			KE63	Stainless steel	AISI 316L
			Seating version W	Stellite™ 6	
	4	Cage		Stainless steel	
	6	Valve seat ring	Seating version T	Stainless steel	AISI 431 S29
			Seating versions P and K	PEEK	
			All others	Stainless steel	Stellite™ 6
	9	Bearing		Stellite™	
	10	Spacer (not used in DN125 valves)		Stainless steel	
	11	Gland nut		Stainless steel	AISI 416
	14	Washer		Stainless steel	AISI 316L
	15	Bonnet gasket		Stainless steel/graphite	
	16	Seat gasket		Stainless steel/graphite	
	20	Stem nut		Stainless steel	AISI 316
	21	Standard bonnet nut	KE43	Carbon steel	BS EN ISO 898-1 Grade 8.8
			KE63	Stainless steel	A2-80
			KE73	Carbon steel	BS EN ISO 898-1 Grade 8.8
			KEA43	Carbon steel	ASTM A194 2H
			KEA63	Stainless steel	ASTM A194 8M
			KEA73	Carbon steel	ASTM A194 2H
High temperature bonnet nut		Stainless steel	DIN ISO 3506 A2		
22		Standard stud	KE43	Carbon steel	BS EN ISO 898-1 Grade 8.8
			KE63	Stainless steel	A2
			KE73	Carbon steel	BS EN ISO 898-1 Grade 8.8
			KEA43	Carbon steel	ASTM A193 B7
			KEA63	Stainless steel	ASTM A193 B8M2
	KEA73		Carbon steel	ASTM A193 B7	
High temperature bonnet nut	KE43 KE73	Stainless steel	DIN ISO 3506 A2-80		
PTFE gland versions	8	Spring		Stainless steel	
	12	Chevron packing set		PTFE	
	17	Stem 'O' ring		Viton™	
	18	Bonnet 'O' ring		Viton™	
High temperature gland versions	26	Gland packing		Graphite	
Balanced versions	3a	Plug and stem assembly		Stainless steel	
	29	Cage		Stainless steel	
	31	Balanced seal		Graphite	

K_v values

Valve size		DN125	DN150	DN200	DN250	DN300	
Standard trim	Full port	Equal %	245	370	580	700	1 000
		Linear	260	390	640	780	1 100
		Fast opening	260	390	640	780	1 100
	Reduced trim 1	Equal %	200	287	370	580	700
		Linear	200	287	550	640	780
	Reduced trim 2	Equal %	100	132	232	370	580
		Linear	100	132	232	550	640
	Reduced trim 3	Equal %	63	103	163	232	370
		Linear	63	103	163	232	550
	Reduced trim 4	Equal %				163	232
		Linear				163	232
	Reduced trim 5	Equal %					163
		Linear					163

Note: For low noise and anti-cavitation K_v please see TI-S24-59

C_v (US) values

$$C_v \text{ (US)} = C_v \text{ (UK)} \times 1.2009$$

Valve size		DN150	DN200	DN250	DN300	
Standard trim	Full port	Equal %	433	679	809	1 156
		Linear	456	749	902	1 272
		Fast opening	456	749	902	1 272
	Reduced trim 1	Equal %	336	433	670	809
		Linear	336	636	740	902
	Reduced trim 2	Equal %	154	271	428	670
		Linear	154	271	636	740
	Reduced trim 3	Equal %	120	191	268	428
		Linear	120	191	268	636
	Reduced trim 4	Equal %			188	268
		Linear			188	268
	Reduced trim 5	Equal %				188
		Linear				188

Note: For low noise and anti-cavitation C_v please see TI-S24-59

Pressure / temperature limits - KE43 (Carbon steel)

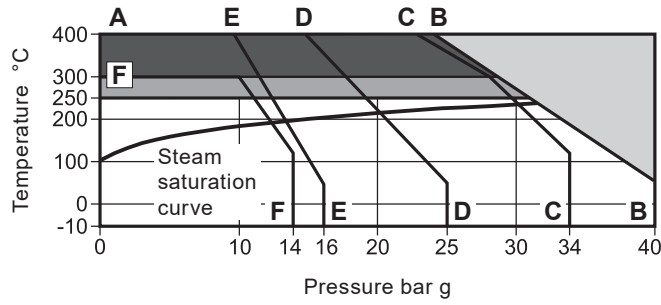

- The product **must not** be used in this region.
- High temperature packing is required for use in this region.
- High temperature bolting and packing is required for use in this region

- A - B** Flanged EN 1092 PN40.
- A - C** Flanged JIS/KS 20K.
- A - D** Flanged EN 1092 PN25.
- A - E** Flanged EN 1092 PN16.
- A - F** Flanged JIS/KS 10K.

Notes:

1. Where the process fluid temperature is sub-zero and the ambient temperature is below +5 °C, the external moving parts of the valve and actuator must be heat traced to maintain normal operation.
2. When selecting a valve with a bellows sealed bonnet, the pressure / temperature limits of the bellows must be read in conjunction with the valve pressure / temperature limits shown in table below.

Body design conditions	PN40	
Maximum design pressure	40 bar g @ 50 °C	
Maximum differential pressure design	PTFE soft seat (G)	7 bar
	PEEK soft seat (K)	7 bar
	Full PEEK seat (P)	19 bar
Maximum design temperature	400 °C	
Minimum design temperature	-10 °C	
Maximum operating temperature	PTFE soft seat (G)	170 °C
	PEEK soft seat (P)	220 °C
	Standard packing PTFE chevron	250 °C
	PEEK seat (K)	250 °C
	Extended bonnet (E) with PTFE chevron	250 °C
	High temperature packing (H)	400 °C
	Extended bonnet (E) with graphite packing	400 °C

Note: We recommend that an extended bonnet (E) with graphite packing is used where valve operation is above 300 °C.

Pressure / temperature limits - KE63 (Stainless steel)

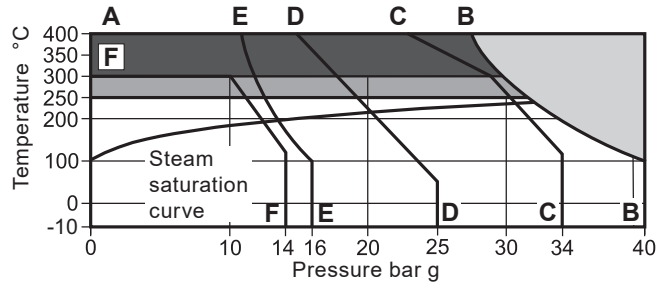

- The product **must not** be used in this region.
- High temperature packing is required for use in this region.
- High temperature bolting and packing is required for use in this region
- A - B** Flanged EN 1092 PN40.
- A - C** Flanged JIS/KS 20K.
- A - D** Flanged EN 1092 PN25.
- A - E** Flanged EN 1092 PN16.
- A - F** Flanged JIS/KS 10K.

Notes:

1. Where the process fluid temperature is sub-zero and the ambient temperature is below +5 °C, the external moving parts of the valve and actuator must be heat traced to maintain normal operation.
2. When selecting a valve with a bellows sealed bonnet, the pressure/temperature limits of the bellows must be read in conjunction with the valve pressure/temperature limits shown in table below.

Body design conditions		PN40
Maximum design pressure		40 bar g @ 50 °C
Maximum differential pressure design	PTFE soft seat (G)	7 bar
	PEEK soft seat (K)	7 bar
	Full PEEK seat (P)	19 bar
Maximum design temperature		400 °C
Minimum design temperature		-10 °C
Maximum operating temperature	PTFE soft seat (G)	170 °C
	PEEK soft seat (P)	220 °C
	Standard packing PTFE chevron	
	PEEK seat (K)	250 °C
	Extended bonnet (E) with PTFE chevron	
	High temperature packing (H)	
	Extended bonnet (E) with graphite packing	400 °C

Note: We recommend that an extended bonnet (E) with graphite packing is used where valve operation is above 300 °C.

Pressure / temperature limits - KE73 (SG iron)

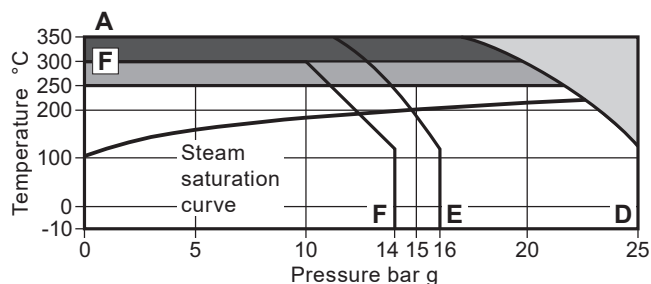

- The product **must not** be used in this region.
- High temperature packing is required for use in this region.
- High temperature bolting and packing is required for use in this region

A - D Flanged EN 1092 PN40.

A - E Flanged EN 1092 PN16.

A - F Flanged JIS/KS 10.

Notes:

1. Where the process fluid temperature is sub-zero and the ambient temperature is below +5 °C, the external moving parts of the valve and actuator must be heat traced to maintain normal operation.
2. When selecting a valve with a bellows sealed bonnet, the pressure/temperature limits of the bellows must be read in conjunction with the valve pressure/temperature limits shown in table below.

Body design conditions	PN25														
Maximum design pressure	25 bar g @ 120 °C														
Maximum differential pressure design	<table border="1"> <tbody> <tr> <td>PTFE soft seat (G)</td> <td>7 bar</td> </tr> <tr> <td>PEEK soft seat (K)</td> <td>7 bar</td> </tr> <tr> <td>Full PEEK seat (P)</td> <td>19 bar</td> </tr> </tbody> </table>	PTFE soft seat (G)	7 bar	PEEK soft seat (K)	7 bar	Full PEEK seat (P)	19 bar								
PTFE soft seat (G)	7 bar														
PEEK soft seat (K)	7 bar														
Full PEEK seat (P)	19 bar														
Maximum design temperature	350 °C														
Minimum design temperature	-10 °C														
Maximum operating temperature	<table border="1"> <tbody> <tr> <td>PTFE soft seat (G)</td> <td>170 °C</td> </tr> <tr> <td>PEEK soft seat (P)</td> <td>220 °C</td> </tr> <tr> <td>Standard packing PTFE chevron</td> <td></td> </tr> <tr> <td>PEEK seat (K)</td> <td>250 °C</td> </tr> <tr> <td>Extended bonnet (E) with PTFE chevron</td> <td></td> </tr> <tr> <td>High temperature packing (H)</td> <td></td> </tr> <tr> <td>Extended bonnet (E) with graphite packing</td> <td>350 °C</td> </tr> </tbody> </table>	PTFE soft seat (G)	170 °C	PEEK soft seat (P)	220 °C	Standard packing PTFE chevron		PEEK seat (K)	250 °C	Extended bonnet (E) with PTFE chevron		High temperature packing (H)		Extended bonnet (E) with graphite packing	350 °C
PTFE soft seat (G)	170 °C														
PEEK soft seat (P)	220 °C														
Standard packing PTFE chevron															
PEEK seat (K)	250 °C														
Extended bonnet (E) with PTFE chevron															
High temperature packing (H)															
Extended bonnet (E) with graphite packing	350 °C														

Note: We recommend that an extended bonnet (E) with graphite packing is used where valve operation is above 300 °C.

Pressure/temperature limits - KEA43 (Carbon steel)

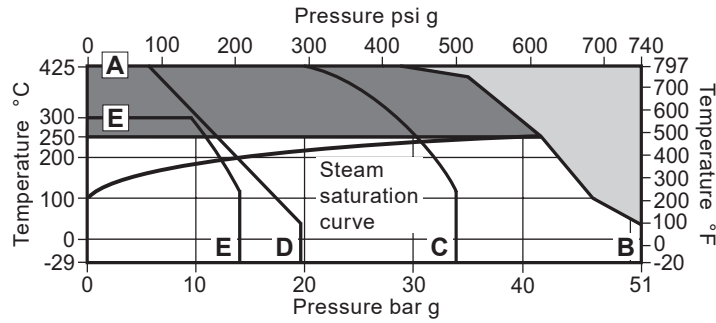

- The product **must not** be used in this region.
- Graphite stem sealing is required for use in this region

- A - B** Flanged ASME 300.
- A - C** Flanged JIS/KS 20.
- A - D** Flanged ASME 150.
- E - E** Flanged JIS/KS 10.

Notes:

1. Where the process fluid temperature is sub-zero and the ambient temperature is below +5 °C, the external moving parts of the valve and actuator must be heat traced to maintain normal operation.
2. When selecting a valve with a bellows sealed bonnet, the pressure/temperature limits of the bellows must be read in conjunction with the valve pressure/temperature limits shown above.
3. As standard the KEA, KFA, KLA series two-port control valves are supplied with the PTFE stem sealing option.

Body design conditions		ASME 150 and ASME 300	
Maximum design pressure	ASME 150	19.6 bar g @ 38 °C	(284 psi g @ 100 °F)
	ASME 300	51.1 bar g @ 38 °C	(740 psi g @ 100 °F)
Maximum differential pressure design	PTFE soft seat (G)	7 bar	
	PEEK soft seat (K)	7 bar	
	Full PEEK seat (P)	19 bar	
Maximum design temperature		425 °C	(800 °F)
Minimum design temperature		-29 °C	(-20 °F)
Maximum operating temperature	PTFE soft seat (G)	170 °C	(338 °F)
	PEEK soft seat (P)	220 °C	(428 °F)
	Standard packing PTFE chevron		
	PEEK seat (K)	250 °C	(482 °F)
	Extended bonnet (E) with PTFE chevron		
	Graphite packing (H)		
	Extended bonnet (E) with graphite packing	425 °C	(800 °F)

Note: We recommend that an extended bonnet (E) with graphite packing is used where valve operation is above 300 °C (572 °F).

Pressure/temperature limits - KEA63 (Stainless steel)

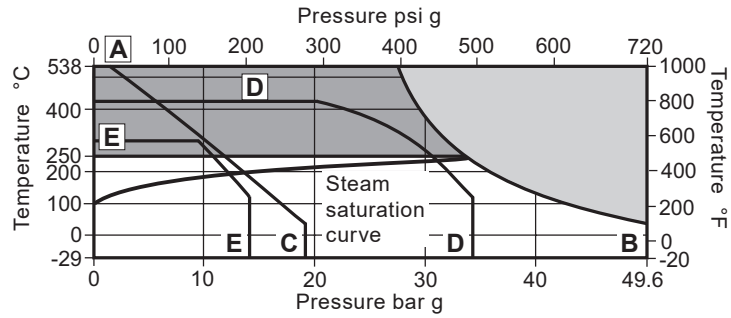

- The product **must not** be used in this region.
- Graphite stem sealing is required for use in this region

- A - B** Flanged ASME 300.
- A - C** Flanged JIS/KS 20.
- D - D** Flanged ASME 150.
- E - E** Flanged JIS/KS 10.

Notes:

1. Where the process fluid temperature is sub-zero and the ambient temperature is below +5 °C, the external moving parts of the valve and actuator must be heat traced to maintain normal operation.
2. When selecting a valve with a bellows sealed bonnet, the pressure/temperature limits of the bellows must be read in conjunction with the valve pressure/temperature limits shown above.
3. As standard the KEA, KFA, KLA series two-port control valves are supplied with the PTFE stem sealing option.

Body design conditions		ASME 150 and ASME 300	
Maximum design pressure	ASME 150 (6" to 8" only)	19.6 bar g @ 38 °C	(275 psi g @ 100 °F)
	ASME 300	49.6 bar g @ 38 °C	(720 psi g @ 100 °F)
Maximum differential pressure design	PTFE soft seat (G)	7 bar	
	PEEK soft seat (K)	7 bar	
	Full PEEK seat (P)	19 bar	
Maximum design temperature		538 °C	(1000 °F)
Minimum design temperature		-29 °C	(-20 °F)
Maximum operating temperature	PTFE soft seat (G)	170 °C	(338 °F)
	PEEK soft seat (P)	220 °C	(428 °F)
	Standard packing PTFE chevron		
	PEEK seat (K)	250 °C	(482 °F)
	Extended bonnet (E) with PTFE chevron		
Maximum operating temperature	Graphite packing (H)		
	Extended bonnet (E) with graphite packing	538 °C	(1000 °F)

Note: We recommend that an extended bonnet (E) with graphite packing is used where valve operation is above 300 °C (572 °F).

Dimensions for the **Spira-trol™ two-port control valve** approximate in mm and (inches)

Valve size	Flanged							D	E Thread	F Extended bonnet
	KE valves			KEA valves						
	PN16 PN25 PN40	A1		C1	A1		C1			
		JIS / KS			KS 10	KS 20				
	10	20		ASME 125 and 150	ASME 250 and 300					
DN125 (5")	400	403	425	257						538 (21 1/8")
DN150 (6")	480	451	473	275	451 (17 3/4")	473 (18 5/8")	279 (11")			556 (21 7/8")
DN200 (8")	600	543	568	341	543 (21 3/8")	568 (22 3/8")	343 (13 1/2")	125(4 7/8")	M30	621 (24 1/2")
DN250 (10")	730	673	708	344	673	708	344 (13 1/2")			622 (24 1/2")
DN300 (12")	850	737	775	355	737	775	355 (14")			634 (25")

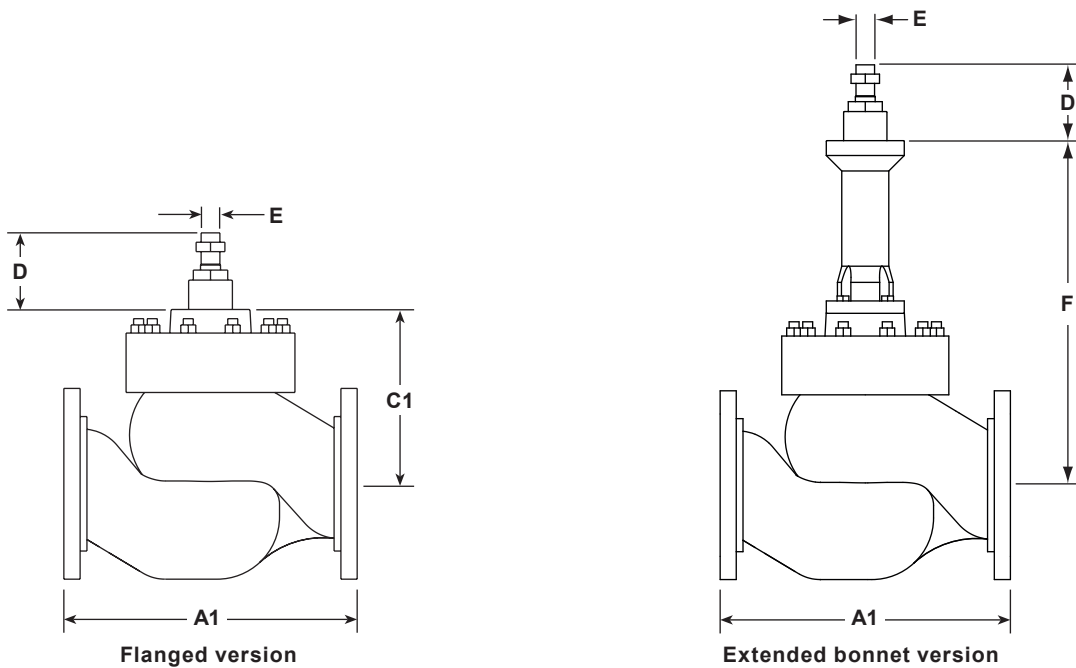

Weights for the **Spira-trol™ two-port control valve** approximate in kg (and lbs)

Valve size	KE valves			KEA valves			Additional Extended bonnet	Additional balanced
	KE43	KE63	KE73	KEA43	KEA63	KEA73		
DN125 (5")	81	81	81				16 (35)	2 (4.4)
DN150 (6")	121	121	121	130 (286)	130 (286)	130 (286)	16 (35)	3 (7)
DN200 (8")	210	210	210	210 (462)	210 (462)	210 (462)	16 (35)	10 (22)
DN250 10")	228			242 (533)			16 (35)	10 (22)
DN300 12")	451			465 (1025)			16 (35)	16 (35)

Dimensions/weights for the **PN actuator range** approximate in mm and kgs (inches and lbs)

Actuator range and variants	F		G		H		J		Weight			
	mm	inches	mm	inches	mm	inches	mm	inches	Actuator		With handwheel	
									kg	lbs	kg	lbs
PN1500 and PN2500	405	16"	1 114	46"					55	121.00		
PN1600 and PN2600	465	18 ⁵ / ₁₆ "	1 116	46"					70	154.00		
PN9400E	732	28 ³ / ₄ "	465	18 ¹ / ₃ "					60	132.00		
PN9400R												
TN2277E	532	21"	863	34"	330	13"	330	13"	116	255.00	+21.00	+46.00
TN2277NDA	532	21"	863	34"					98	216.00		

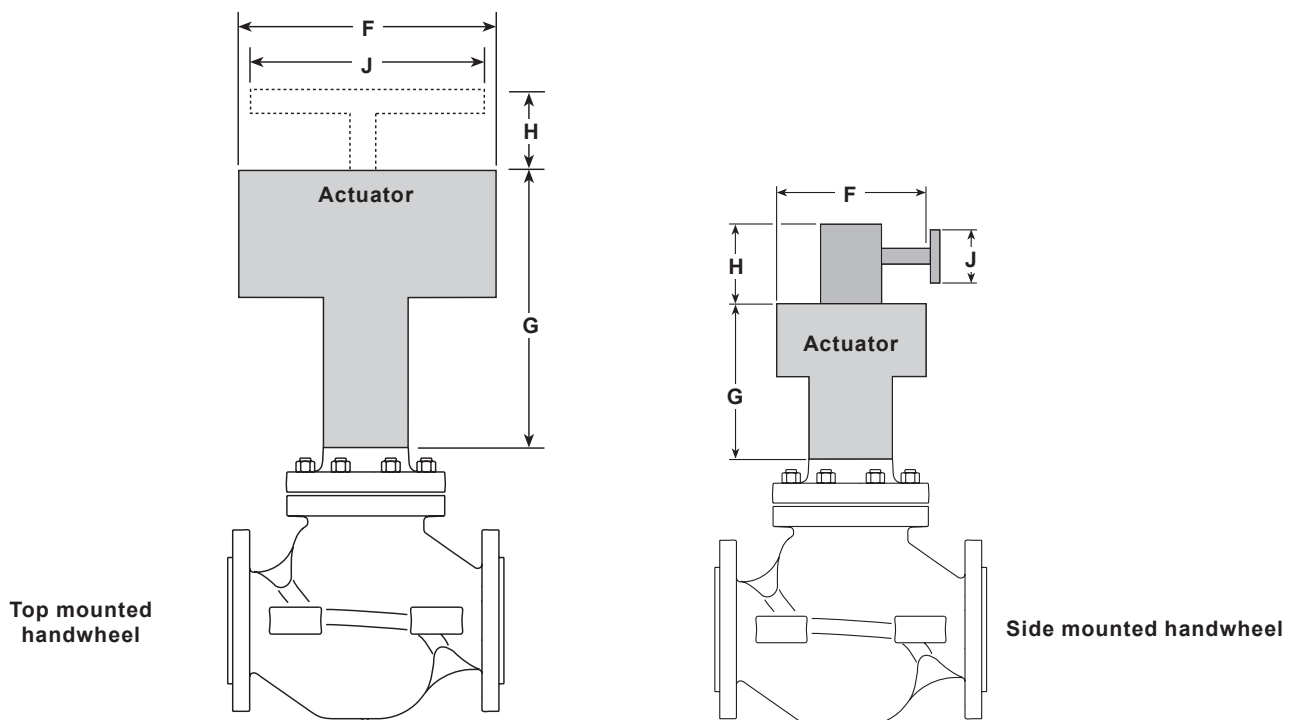

Dimensions/weights for the **EL and AEL actuator ranges** approximate in mm and kgs (and in inches and lbs)

Actuator range	F		G		Weight	
	mm	inches	mm	inches	kg	lbs
AEL56 and AEL66	226	9"	760	30"	20.0	44.0

Spare parts

Spira-trol™ two-port control valve Balanced and unbalanced DN125 to DN300 and 6" to 12"

The spare parts available are shown in solid outline. Parts drawn in a grey line are not supplied as spares.

Note: When placing an order for spare parts please specify clearly the full product description as found on the label of the valve body, as this will ensure that the correct spare parts are supplied.

Available spares - K series

Gasket set Non bellows sealed	Balanced	A, B, G
	Unbalanced	B, G
Stem seal kit	PTFE chevrons	C3
	Graphite packing conversion kit (DN15 to DN100)	C4
	Graphite seal set	C5
Plug stem and seat kit	Balanced (No gaskets supplied)	A, D, E
	Unbalanced (No gaskets supplied)	D, E

How to order spares

Always order spares by using the description given in the column headed 'Available spares', and state the size and type of valve including the full product description of the product.

Example: 1 - PTFE stem seal kit for a Spirax Sarco DN150 Spira-trol™ two-port KE43 PTSBSS.2 Kvs 370 control valve.

How to fit spares

Full fitting instructions are given in the Installation and Maintenance Instructions supplied with the spare.

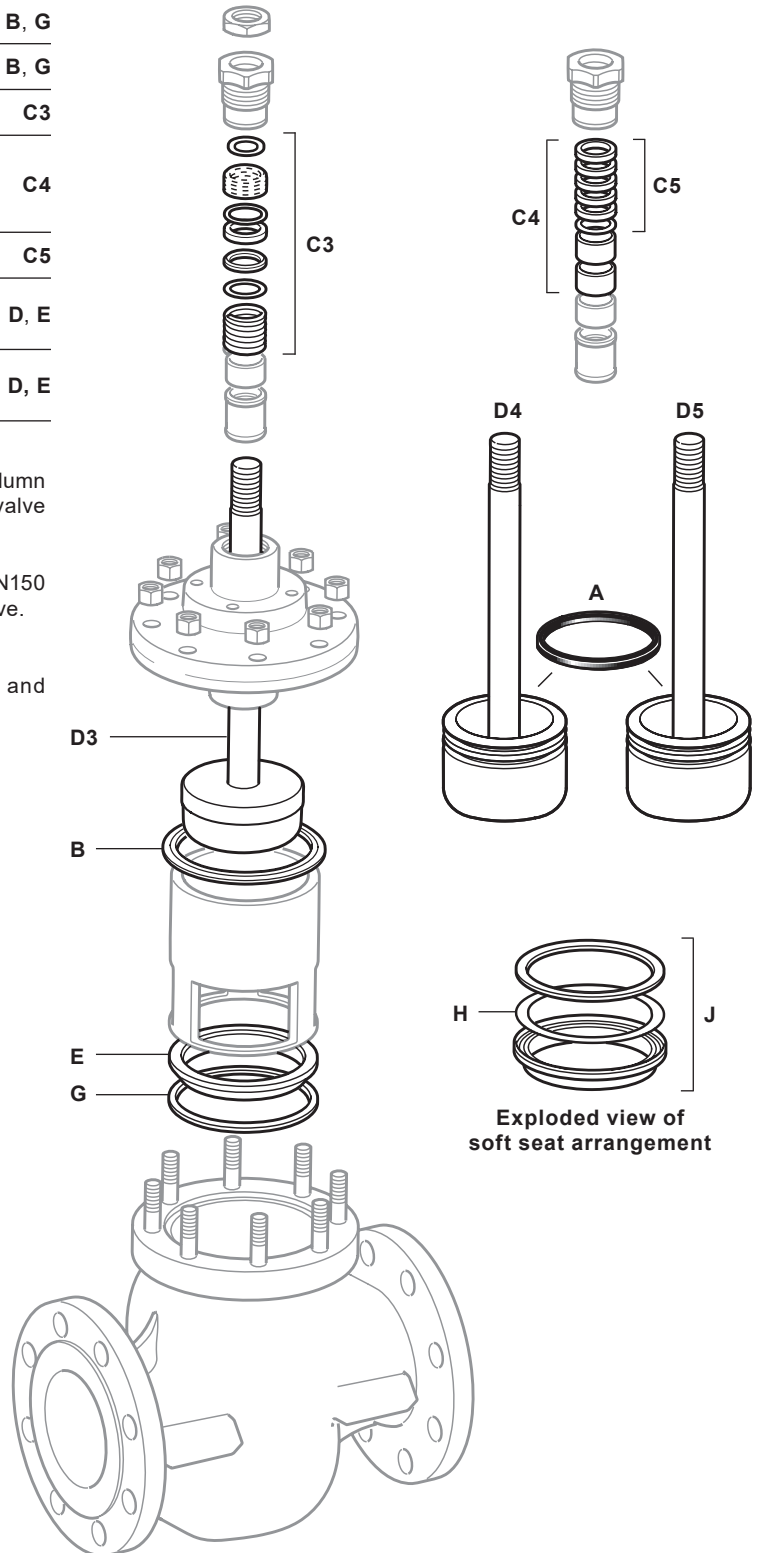

Spira-trol™ selection guide:

Valve size	EN standard = DN125, DN150, DN200, DN250 and 300 ASME standard = 6", 8", 10" and 12"	DN150
Valve series	K = K series 2-port control valve	K
Valve characteristic	E = Equal percentage F = Fast opening L = Linear	E
Flange type	A = ASME Blank = EN (PN)	Blank
Flow	Blank = under T = over	Blank
Body material	4 = Carbon steel 6 = Stainless steel 7 = SG iron	4
Connections	3 = Flanged	
Stem sealing	H = Graphite P = PTFE V = PTFE for vacuum service	
Seating	G = PTFE soft seat K = PEEK soft seat P = Full PEEK T = 431 stainless steel W = 316L with stellite 6 facing	T
Type of trim	A1 = 1 stage anti-cavitation A2 = 2 stage anti-cavitation P1 = 1 stage low noise cage P2 = 2 stage low noise cage P3 = 3 stage low noise cage S = Standard trim	S
Trim balancing	B = Balanced U = Unbalanced	U
Bonnet type	E = Extended S = Standard	S
Bolting	H = High temperature S = Standard	S
Finish	Blank = Standard	
Series	2 = .2	.2
Kvs	To be specified	Kvs 370
Connection type	To be specified	Flanged PN40

Selection example:

DN150	-	K	E	4	3	P	T	S	U	S	S		.2	-	Kvs 370	-	Flanged PN40
-------	---	---	---	---	---	---	---	---	---	---	---	--	----	---	---------	---	--------------

How to order

Example: 1 off Spirax Sarco Spira-trol™ DN150 KE43PTSUSS.2 Kvs 16 two-port control valve having flanged PN40 connections.