



9800 and 9800Z Condensate Separators for Compressed Air and Gas

Description

Water is present in all compressed air and in certain number of gas distribution pipelines systems; in fact atmospheric air contains water in vapour form, but when air is compressed and cooled down by refrigerators or even naturally, its water carrying capacity is reduced, so water precipitates out as a mist of droplets and his effect on the plant may be quite serious, like water hammer, corrosion, imperfect working of pistons, valves, tools, etc. and generally bad plant performance.

The most practical way to extract the majority of water droplets from compressed air is by using a separator. It provides a drain point for water droplets moving along the pipe wall and deflects suspended moisture out of the main flow.

One or more main separators should be fitted after compressor (or after intercooler and aftercooler, if any) and before general filter or drier if present.

Secondary and smaller size separators should be fitted in every branch section of plant supplying every important usage point or group of them.

Separators remove enough moisture from air to make it sufficiently dry for many compressed air applications; were even more dry air is required, they reduce the load on special drying filters or systems installed downstream.

Air passing through the separator has to flow round a series of baffles. Because the cross section of the separator is large compared with the pipe bore, the velocity of the flow is reduced. The water droplets, having greater inertia, continue moving in a straight line and impinge on the baffles, from where they drain away.

The moisture in compressed air is removed with 95-98% efficiency. The baffles are so designed that the separated water is diverted from the main path of the air to prevent re-entrainment, which is also opposed by reduced velocity.

Drainage is then completed by a suitable liquid drainer.

Standards

The condensate separators 9800 series are designed and manufactured according to the requirement of the European Pressure Equipment Directive 2014/68/EU.

Certification

Separators are available on demand with material certification to EN10204 3.1.

Note: all certification / inspection requirement must be stated at the time of order placement.

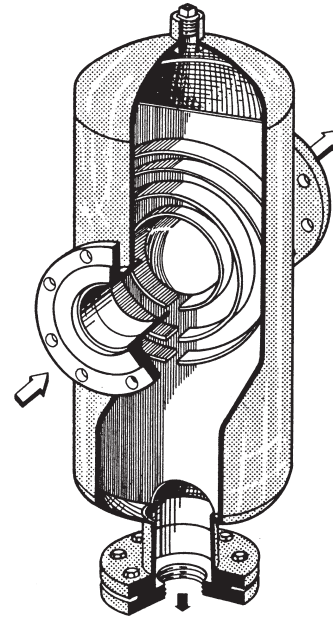

Technical features

Use	Condensate separation on compressed air or non dangerous gas (PED group 2)				
Models and working conditions	Type	Max. working pressure	Maximum temperature	Size DN	Flanged connections
	9800	25 bar g	150°C	15 to 250	UNI 6084/2229 PN 40
	9800Z	13 bar g	150°C	65 to 250	UNI 2278/2229 PN 16
Material	Body and internal parts		Fabricated carbon steel - zinc plated		
CE Mark Category Gas and Liquid Group 2	Modello 9800Z		DN 65 to 80 DN 100 to 150 DN 200 to 250	Category 2 Category 3 Category 4	
	Modello 9800		DN 15 to 32 DN 40 to 65 DN 80 to 125 DN 150 to 250	Category 1 Category 2 Category 3 Category 4	

How to size

To choose the separator size, make reference to the following maximum capacities table.

The capacities are expressed in actual volume and, should the plant flow be expressed at standard conditions (atmospheric pressure and 0°C, as normally used for compressors), it will be necessary to make the appropriate conversion. To convert standard capacity to actual capacity use the following formula:

$$Q_f = Q_n \frac{(273 + t_f)}{273} \cdot \frac{1,013}{(1,013 + p_f)} \text{ where}$$

Q_f = air or gas actual flow at operating conditions (m³/h)
 Q_n = air or gas flow standard conditions: 0 bar @ 1,013 bar_a (Nm³/h)
 t_f = air or gas actual temperature at operating conditions (°C)
 p_f = air or gas actual pressure at operating conditions (bar g)

Example: select a separator for flow of 250 Nm³/h of air at 30°C and a pressure of 6 bar g.

$$Q_f = 250 \frac{(273 + 30)}{273} \cdot \frac{1,013}{(1,013 + 6)} = 40,08 \text{ m}^3/\text{h}$$

From the capacity table a separator DN 32 size will be selected. On existing pipe lines a separator matching the pipework size is usually satisfactory; never use a smaller size. On new plants is advisable to proceed as first to the pipe sizing and afterwards to the selection of the appropriate size of separators.

Maximum air capacity (actual flow m³/h) 9800 and 9800Z separators

Size DN	Maximum flow m ³ /h (actual)	Size DN	Maximum flow m ³ /h (actual)
15	10	80	250
20	15	100	400
25	25	125	600
32	45	150	900
40	65	200	1700
50	100	250	2700
65	150		

Safety information, installation and maintenance

For full details see the Installation and Maintenance Instructions supplied with the products.

Installation

Separators 9800 series must be installed in line with the pipe, with the discharge connection at the bottom and according with the direction of the flow indicated by the arrow on the body. The separator must be equipped with a suitable liquid drainer, air trap type CA14 or CA44, sized for the maximum condensate flow to be discharged. For separator up to DN 50 a CA14 trap is usually appropriate. The liquid drainer must be protected with a strainer installed upstream and the model CA44 trap must be connected with the upper vent connection on the separator by means of a balancing pipe 3/8" size. For type CA14 the balancing connection is not required due to lower condensate flow, see Fig. 1 and 2.

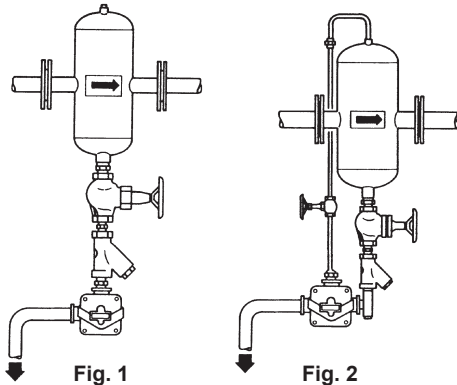

Note: with low condensate flow and CA14 air trap a compact installation and no balancing pipe are accepted (Fig. 1); for higher flow, a CA44 air trap and a balancing connection are required (Fig. 2).

The product can not withstand external stresses that may be induced by any system / pipe to which they are fitted. Adequate precautions must be taken to minimise external stresses by properly fixing upstream and downstream pipes. It will be advisable to arrange for a suitable insulation after having protected the external surface with an heat resistant coating.

Maintenance

No specific maintenance are required by condensate separators. Possible foreign bodies and materials can be blown out through the plug of the strainer installed upstream the liquid drainer. For a more efficient and accurate cleaning by washing and eventually to extract foreign bodies of bigger dimensions, open the lower cover, having disconnected the liquid drainer group. That can be considered as extraordinary maintenance or a requirement of new plant start up.

Dimensions in mm and weights in kg (approximate)

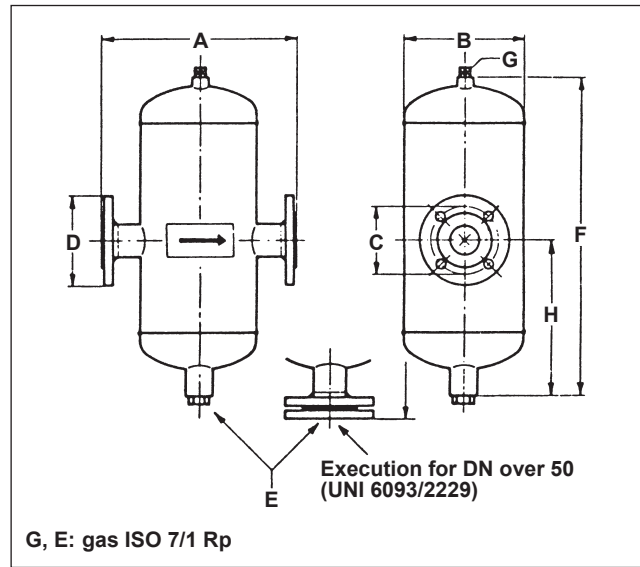

DN	Type 9800								Weight
	A	B	C	D	E	F	G	H	
15	188	108	65	95	½"	300	¾"	163	6
20	265	133	75	105	¾"	328	¾"	166	8
25	265	133	85	115	¾"	365	¾"	184	10
32	308	168	100	140	¾"	417	¾"	214	15
40	359	219	110	150	¾"	507	¾"	248	21
50	359	219	125	165	¾"	573	¾"	278	24
65	433	273	145	185	1"	704	¾"	348	55
80	494	324	160	200	1"	864	¾"	423	85
100	586	410	190	235	1"	965	¾"	474	110
125	606	410	220	270	1½"	1106	¾"	540	130
150	708	510	250	300	1½"	1205	¾"	599	175
200	950	616	320	375	1½"	1630	¾"	821	310
250	950	616	385	450	1½"	1780	¾"	888	380

DN	Type 9800Z								Weight
	A	B	C	D	E	F	G	H	
65	433	273	145	185	1"	704	¾"	348	38
80	494	324	160	200	1"	864	¾"	423	54
100	586	410	180	220	1"	965	¾"	474	75
125	606	410	210	250	1½"	1106	¾"	540	84
150	708	510	240	285	1½"	1205	¾"	599	110
200	950	616	295	340	1½"	1630	¾"	821	210
250	950	616	355	405	1½"	1780	¾"	888	245