EP5 and ISP5 Series
Electropneumatic Positioners
Installation and Maintenance Instructions

Attention: Additional instructions are required when a ATEX intrinsically safety instrument ISP5 is used in an explosion risk area.



1. Safety information
2. Introduction
3. Installation
4. Commissioning
5. Maintenance
6. Spare parts
7. Fault finding

1. Safety information

Safe operation of these products can only be guaranteed if they are properly installed, commissioned, used and maintained by qualified personnel (see paragraph 1.11) in compliance with the operating instructions. General installation and safety instructions for pipeline and plant construction, as well as the proper use of tools and safety equipment must also be complied with.



WARNING: The maximum process fluid temperature must be suitable for use if the unit is to be used in any potential explosive atmosphere. For the device maintenance in a potentially explosive atmosphere, we recommend the usage of tools which do not produce and/or propagate sparks.

1.1 Intended use

Referring to the Installation and Maintenance Instructions, name-plate and Technical Information Sheet, check that the product is suitable for the intended use / application. The products comply with the requirements of the European Directive 2014/34/EU (ATEX).

1.2 Access

Ensure safe access and if necessary a safe working platform (suitably guarded) before attempting to work on the product. Arrange suitable lifting gear if required.

1.3 Lighting

Ensure adequate lighting, particularly where detailed or intricate work is required.

1.4 Hazardous liquids or gases in the pipeline

Consider what is in the pipeline or what may have been in the pipeline at some previous time. Consider: flammable materials, substances hazardous to health, extremes of temperature.

1.5 Hazardous environment around the product

Consider: explosion risk areas, lack of oxygen (e.g. tanks, pits), dangerous gases, extremes of temperature, hot surfaces, fire hazard (e.g. during welding), excessive noise, moving machinery.

1.6 The system

Consider the effect on the complete system of the work proposed. Will any proposed action (e.g. closing isolation valves, electrical isolation) put any other part of the system or any personnel at risk? Dangers might include isolation of vents or protective devices or the rendering ineffective of controls or alarms. Ensure isolation valves are turned on and off in a gradual way to avoid system shocks.

1.7 Pressure systems

Ensure that any pressure is isolated and safely vented to atmospheric pressure. Consider double isolation (double block and bleed) and the locking or labelling of closed valves. Do not assume that the system has depressurised even when the pressure gauge indicates zero.

1.8 Temperature

Allow time for temperature to normalise after isolation to avoid danger of burns.

1.9 Tools and consumables

Before starting work ensure that you have suitable tools and/or consumables available. Use only genuine Spirax Sarco replacement parts.

1.10 Protective clothing

Consider whether you and/or others in the vicinity require any protective clothing to protect against the hazards of, for example, chemicals, high/low temperature, radiation, noise, falling objects, and dangers to eyes and face.

1.11 Permits to work

All work must be carried out or be supervised by a suitably competent person.

Installation and operating personnel should be trained in the correct use of the product according to the Installation and Maintenance Instructions.

Where a formal 'permit to work' system is in force it must be complied with. Where there is no such system, it is recommended that a responsible person should know what work is going on and, where necessary, arrange to have an assistant whose primary responsibility is safety.

Post 'warning notices' if necessary.

1.12 Handling

Manual handling of large and/or heavy products may present a risk of injury. Lifting, pushing, pulling, carrying or supporting a load by bodily force can cause injury particularly to the back. You are advised to assess the risks taking into account the task, the individual, the load and the working environment and use the appropriate handling method depending on the circumstances of the work being done.

1.13 Residual hazards

In normal use the external surface of the product may be very hot. If used at the maximum permitted operating conditions the surface temperature of some products may reach temperatures of 176°F. Many products are not self-draining. Take due care when dismantling or removing the product from an installation (refer to 'Maintenance instructions').

1.14 Freezing

Provision must be made to protect products which are not self-draining against frost damage in environments where they may be exposed to temperatures below freezing point.

1.15 Disposal

Unless otherwise stated in the Installation and Maintenance Instructions, this product is recyclable and no ecological hazard is anticipated with its disposal providing due care is taken.

1.16 Returning products

Customers and stockists are reminded that under EC Health, Safety and Environment Law, when returning products to Spirax Sarco they must provide information on any hazards and the precautions to be taken due to contamination residues or mechanical damage which may present a health, safety or environmental risk. This information must be provided in writing including Health and Safety data sheets relating to any substances identified as hazardous or potentially hazardous.

2. Introduction

2.1 Introduction

The EP5 is a 2 wire loop powered positioner requiring a 4-20 mA control signal, and is designed for use with linear pneumatic valve actuators. The positioner compares the electrical signal from a controller with the actual valve position and varies a pneumatic output signal to the actuator accordingly. The desired valve position is therefore maintained for any control signal and the effects of varying differential pressure, stem friction and hysteresis are overcome. A mounting kit is supplied to suit all NAMUR standard columns or yokes.

Note: A 0-10 Vdc input signal and an intrinsically safe version ISP5 are also available.

2.2 Operating principle

The EP5 operates on a force balance principle by means of a nozzle/flapper mechanism and a feedback spring (refer to Figure 1).

The electrical control signal (**A**) is converted into a proportional air pressure (**I**). This pressure is applied to the flapper (**5**) via the receiver (**1**), causing a deflection of the flapper relative to the nozzles **U1/U2**. From the air supply (**S**) a reduced bleed of air is fed to the amplifier relay (**2**) and into one of the nozzles **U1/U2**. As the flapper moves the pressure drop through the nozzle is sensed by the amplifier relay. The amplifier relay outputs a signal (**O**) to the actuator which is proportional to the pressure drop through the nozzle.

As the actuator moves, connecting lever (**8**) causes a change in tension of the reaction spring (**6**). This tension is applied to the flapper causing it to move to a new position at which the forces applied by the spring and the applied pressure (**I**) balance.

- 1 = Receiver 0.2 to 1 bar (3 to 15 psi)
- 2 = Amplifier relay
- 3 = Adjustable orifice: sensitivity setting
- 4 = Damping: outlet air flow adjustment
- 5 = Flapper
- 6 = Reaction spring
- 7 = Zero screw
- 8 = Positioner lever
- 9 = Lock-nut
- 10 = Slider
- 11 = Sector lever

- A** = Control signal
- I** = I/P converter output
- S** = Air supply
- O** = Positioner output
- U1** = Increase action nozzle
- U2** = Decrease action nozzle

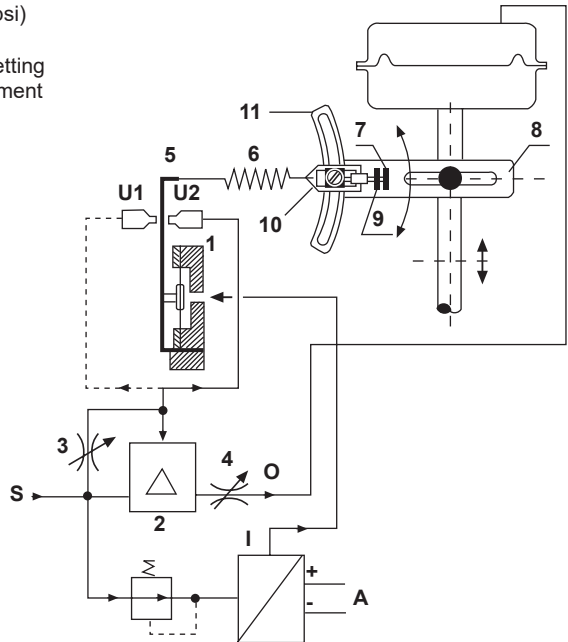

Fig. 1

Important: This instrument bleeds air in normal operation at a rate of approximately 0.7 N m³ / hour at a supply pressure of 6 bar.

3. Installation

Note: Before starting any installation observe the 'Safety information' in Section 1.

This publication is provided as a guide and it is recommended that it is read thoroughly prior to installation. Also refer to the separate Installation and Maintenance Instructions for the control valve and actuator.

3.1 Location

The positioner should be mounted in sufficient space to allow removal of the cover and provide access to connections. When fitting to an actuator, ensure the positioner will not be exposed to an ambient temperature outside the range -15°C to +65°C. The positioner enclosure is rated to IP54 see BS EN 60534-6-1 1998.

Connection of air supply pressure (1.4 to 6 bar g) and control signal (4-20 mA or 0-10 Vdc) should be considered prior to choice of location.

3.2 Mounting the positioner onto the actuator

The EP5 positioner may have been supplied already factory fitted onto the valve actuator. However, using the mounting kit provided it can be attached retrospectively onto any other type of valve and actuator conforming to NAMUR standards.

Step 1 Identify actuator type

For correct operation it is important to know two factors which will affect optimum movement of the positioner feedback mechanism:

- The distance between the axes of the valve/actuator stem and the positioner slide pin.
- The travel of the valve actuator.

To ensure these are set correctly, please note the following:

- When attaching an EP5 to any Spirax Sarco valve actuator, ignore Step 3.
- For non-Spirax Sarco actuators, ignore Step 2.

Step 2 For attachment to Spirax Sarco actuators

Using the 2 off M6 pan head screws, securely attach the 'T' shaped sliding pin holder to the valve actuator coupling block (Figure 2). Apply Loctite to the sliding pin and screw into hole 'Y' (as shown) on the sliding pin holder and tighten.

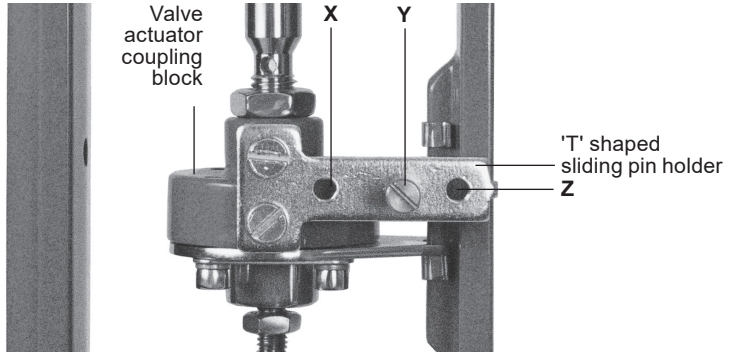

Fig. 2
Close-up of sliding pin holder fitted to valve coupling.

Using the 2 off M8 x 15 hex head screws and 8 mm spring washers, attach the mounting plate to the back of the positioner, utilising holes No. 2 in the bracket (Figure 3). Take care not to over-tighten these screws and strip the threads.

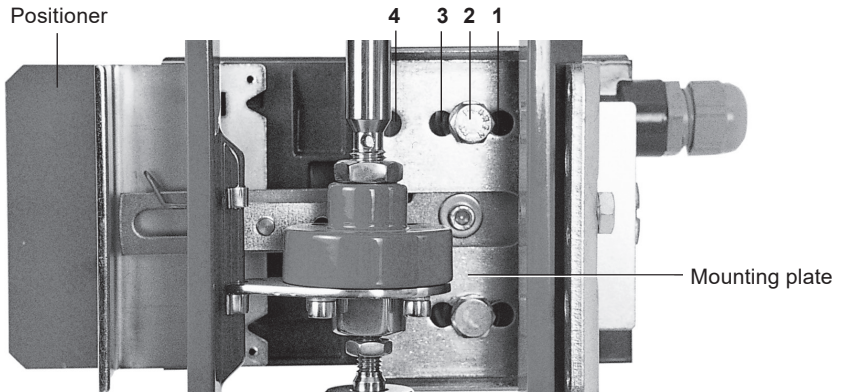

Fig. 3

Step 3 For attachment to non-Spirax Sarco actuators

Using the 2 off M6 pan head screws, securely attach the 'T' shaped sliding pin holder to the valve actuator coupling block (Figure 2). Depending on the travel of the valve actuator, apply Loctite to sliding pin and screw into the correct hole on the sliding pin holder and tighten. Use Figure 2 and Table 1 to determine the correct hole to use.

Table 1

Valve travel	Hole to be used
8 - 15 mm	X
15 - 30 mm	Y
above 30 mm	Z

Using the 2 off M8 x 15 hex head screws and 8 mm spring washers, attach the mounting plate to the back of the positioner. The correct fixing hole may be determined by reference to Figure 3, Table 2 and Figure 4. Take care not to over-tighten these screws and strip the threads.

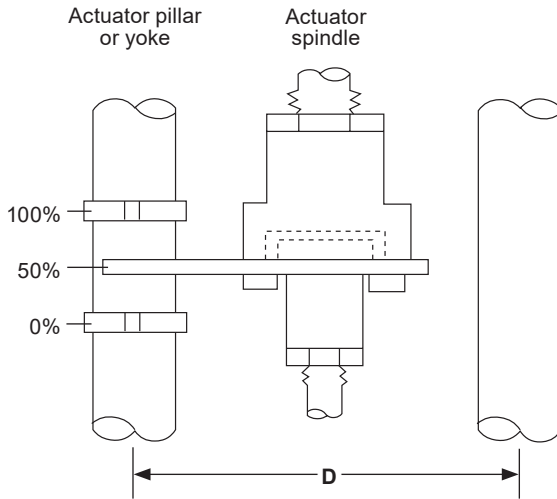

Fig. 4 Pillar/yoke spacing, showing 50 % travel.

Table 2

D	Hole to be used
Up to 125 mm	1
125 to 150 mm	2
150 to 175 mm	3
above 175 mm	4

Step 4 Temporarily apply adequate air pressure directly into the actuator so that the valve is at 50% of travel (Figure 5).

Step 5 Engage the slide pin into the positioner lever (see Figure 5, noting the position of the spring, above the pin) and loosely fix the positioner to the actuator. For yoke actuators use the single elongated screw hole with the M8 x 20 screw and spring washer, for pillars use the U-clamps.

Important: Slide positioner vertically up or down the yoke/pillars so the positioner lever is horizontal at 50% travel, and the indicator at LHS is aligned (Figure 5). Secure the tightening screws/nuts.

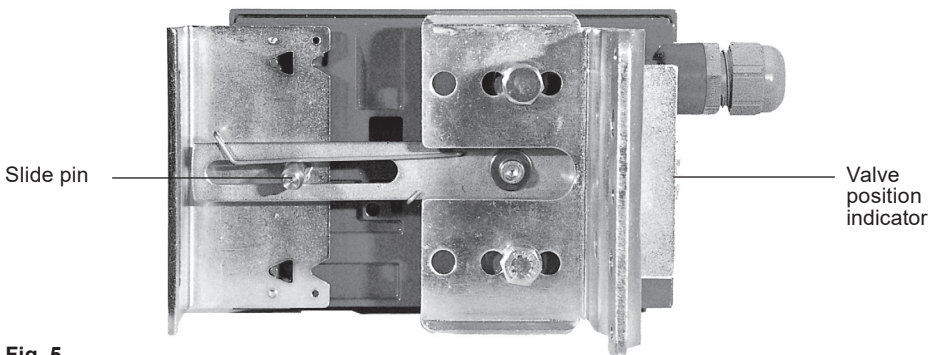

Fig. 5

Step 6 Fit the angled protection plate to the rear of the positioner using the 2 off captive M3 pan head screws. Access to these captive screws is from inside the positioner.

Step 7 Adjust the air supply pressure to stroke the actuator from 0% to 100% and ensure the positioner lever rotates freely. Remove the temporary air supply from the actuator.

Step 8 Fitting a gauge block (optional)

To aid commissioning it is recommended to fit a gauge block and pressure gauges to all EP5s. Please note that gauges and gauge block can be supplied as spare parts if required.

Fit gauges to the block before attaching the block to the EP5. Use thread sealant to ensure air tight connections. The upper gauge displays the output of the I/P converter, and is normally 0 - 2 bar g. The lower gauge displays the positioner output pressure, so the gauge range will depend on the actuator.

Remove any air fittings and blanking plug from the EP5, then attach the assembled block to the EP5 using the 2 off socket head cap screws supplied. Ensure the sealing 'O' rings are correctly fitted to seal the joints between the EP5 body and the gauge block. Replace the fittings and blanking plug into the corresponding ports on the gauge block.

3.3 Connecting up

3.3.1 Pneumatic connections (with or without a gauge block)

Warning: Air supply must be dry, oil and dust free to ISO 8573-1: class 2:3:1. A coalescing filter regulator such as a Spirax Sarco MPC2 will remove oil and dirt to meet this standard if properly fitted and maintained. Dirty air supply may damage the product and invalidate warranty.

The supply air pressure must not exceed the maximum allowable air pressure of the actuator.

Avoid use of ferrous pipe work after the MPC2. For best performance, set the air supply pressure to about 0.5 bar g above the pressure required to fully travel the actuator.

Check all connections for leaks. Please note however that the EP5 bleeds air in normal operation at a rate of approximately 0.7 N m³/hour at 6 bar supply pressure.

Pneumatic connections are located at the right hand end of the positioner and identified **I**, **S** and **O** as follows:

- I** - Not used on EP5, fit ¼" NPT plug.
- S** - Air supply - 1.4 bar g to 6 bar g, depending upon required actuator spring range.
- O** - Output signal to the actuator.

Connections are ¼" NPT female. Interconnection between positioner and actuator should be at least 6 mm OD tube.

3.3.2 Electrical connections

Cabling should be installed in accordance with BS 6739 - Instrumentation in Process Control Systems: Installation design and practice or local equivalent.

The EP5 only requires a 4 - 20 mA (standard) or 2 - 10 Vdc (if requested) signal. Remove the front cover and locate the terminal block and earth terminal post (Figure 6).

Note: Ensure resistance from earth post to local earth (e.g. pipework) is less than 1 Ω .

Connection to the unit is through the Pg 13.5 cable gland (as supplied), which when used with suitable cable will ensure the IP54 protection rating. Appropriate conduit connections may be used instead.

Connect conductors (0.5 to 2 mm²) to the terminal block and earth post (3 mm²) noting the polarity +/- shown in Figure 6.

In hazardous areas use model ISP5 with intrinsic protection (type EEx ia IIC T6, T5, T4) ensuring the power supply from adjoining equipment is certified in accordance with EN 50.014 and EN 50.020 standards, in respect of the limits of electric features shown at approval stage. Refer to approval certificate supplied with each ISP5 product.

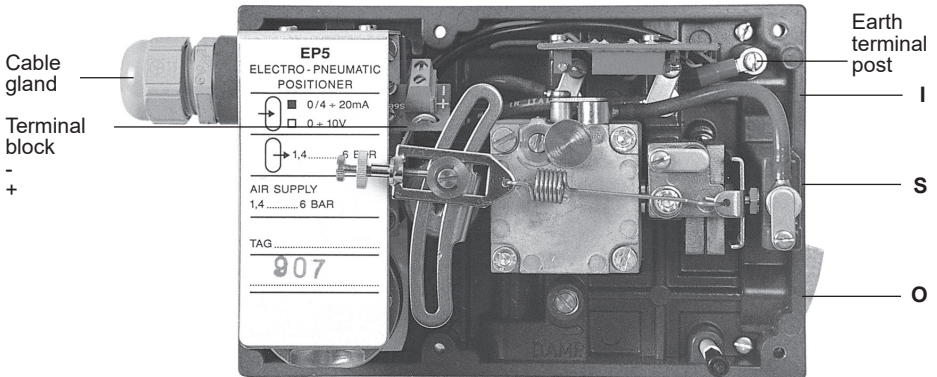

Fig. 6

4. Commissioning

Once the positioner has been mounted and connected up, proceed as follows.

Step 1 Set the valve action

Establishing the correct action of the valve is done by:

- a. Connection to either U1 or U2 nozzles (see Figure 7) and
- b. Setting the slider in the upper or lower portion of the crescent shaped sector lever (Figure 8).

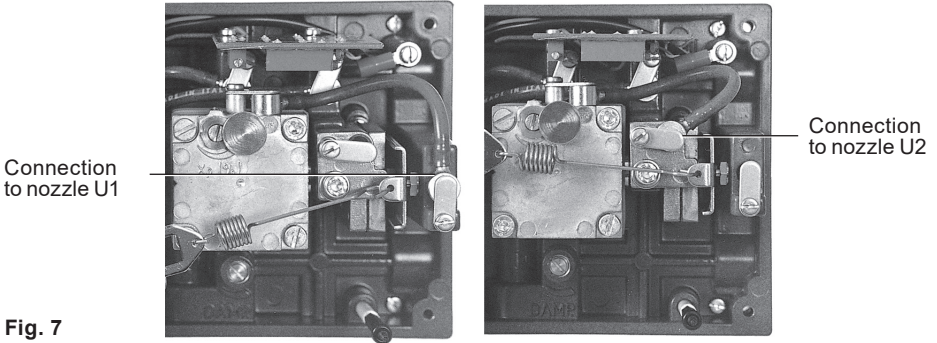

U1 = Increase action = With increasing electrical control signal the air pressure to the actuator will increase.

U2 = Decrease action = With increasing electrical control signal the air pressure to the actuator will decrease.

To change the working nozzle connections (U1 or U2):

Disconnect the air supply. Loosen the retaining plate and rotate it clear of the tube holder. Pull the tube holder clear of its seat and re-insert the tube holder into the alternative seat location. Lock in place with alternative retaining plate (lock unused retaining plate to prevent loss of plate). Reconnect air supply.

To change the slider location:

Refer to Figure 8 to determine the correct portion. To change the slider slacken the screw and slide it into the correct portion of the arm.

Fig. 8a Increase action and spring extend

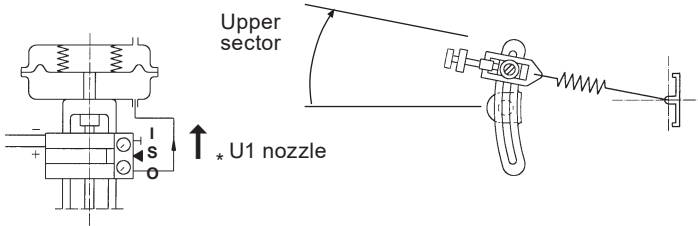

Fig. 8b Increase action and spring retract

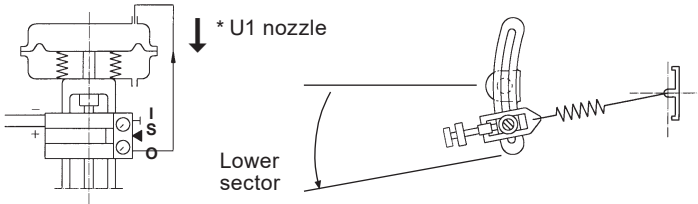

Fig. 8c Decrease action and spring extend

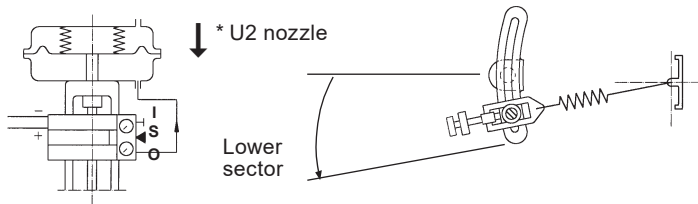
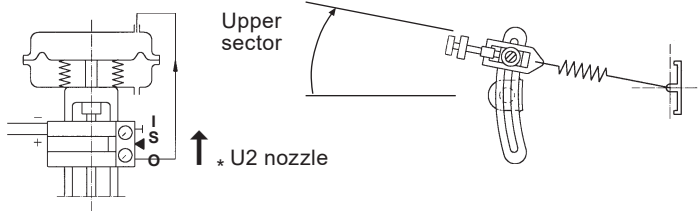

Fig. 8d Decrease action and spring retract



* The arrow shows the stem movement direction when the input control signal increases.

Step 2 Set sensitivity

The positioner sensitivity is adjusted using the sensitivity screw (Xp %, see Figure 10). It is set depending on air supply pressure. Before the commissioning stage it is essential to set the sensitivity within a proportional band of (3% to 6%). Use Figure 10 to adjust the sensitivity screw by firstly fully closing the screw (clockwise), then reopen the screw:-

Supply pressure (S)	1.4 bar - Screw open $\frac{3}{4}$ of a turn
	4.0 bar - Screw open $\frac{1}{4}$ of a turn
	6.0 bar - Screw open $\frac{1}{8}$ of a turn

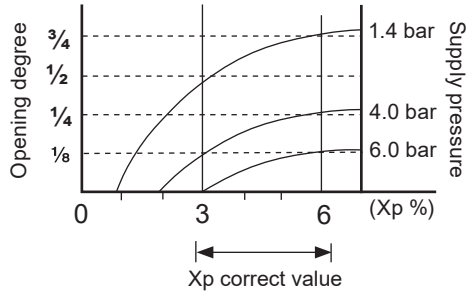

Fig. 9

To increase positioner sensitivity close the adjusting screw, to decrease sensitivity open the screw. **Do not** open the screw beyond the mechanical lock.

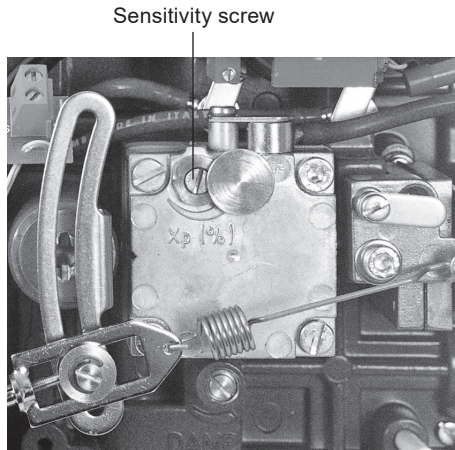

Fig. 10

Note: Adjustment of the Xp % screw causes a change of positioner 'zero' point, and it is therefore important to repeat the zeroing and travel setting procedures (Steps 4 and 5) after any changes.

Step 3 Set damping

The final adjustment of damping screw should be performed with plant in operation, in order to limit, if necessary, the actuation speed. During the commissioning set the damp screw flush with the body see Figure 11.

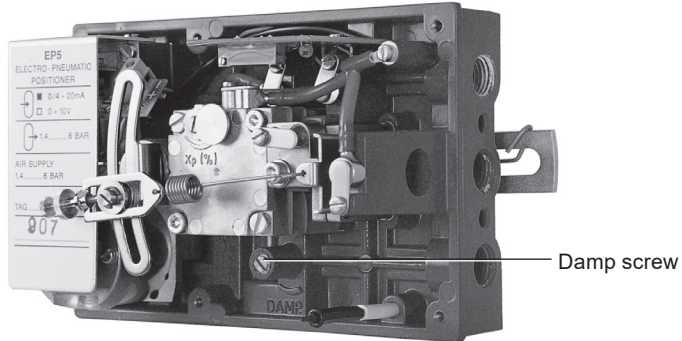

Fig. 11

The reduction of air flowrate capacity to the actuator will slow down the valve movement to limit the effect of cycling hunting. Closing the screw (clockwise) increases damping, and vice versa.

Step 4 Set zero point

Check all air and electrical connections are in place. Check air supply pressure (**S**) is correct (see Section 3.3.2). Check electrical control signal (**A**) (see Section 3.3.3) is at the minimum required (normally 4 mA or 0 V), but the application may require a different setting. It may also be advisable to increase the minimum by 0.5 mA or 0.25 V to ensure the valve is completely closed. For 3-port valves (or if the action has been reversed for 2-port valves) a higher electrical signal corresponds to the closed valve position, it may be beneficial to decrease the maximum electrical control signal to 19.5 mA or 9.75 V. This will ensure that the valve is firmly seated when the full electrical signal of 20 mA or 10 V is applied.

Locate zero point adjustment screw (see Figure 12) and release the locking ring. Adjust screw until the valve starts to move and lock the adjuster in place.

Check the zero point by reducing the electrical control signal (**A**) (see Section 3.3.3) to zero. Slowly increase the electrical control signal towards the minimum level whilst monitoring valve movement. Should movement take place before or after the minimum level control signal then repeat adjustment until movement coincides with minimum control signal.

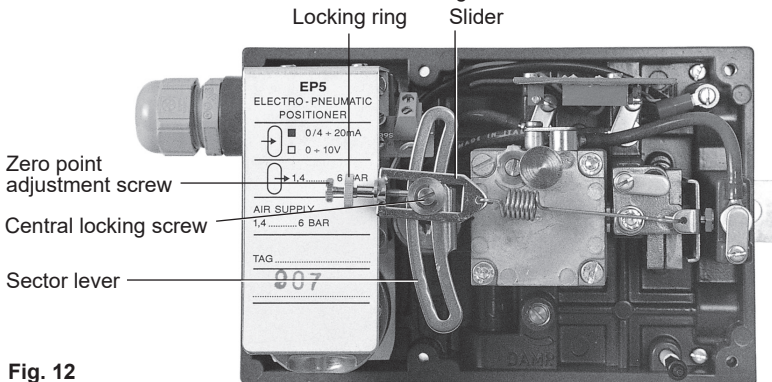

Fig. 12

Note: Positioners fitted with a gauge block have the benefit of anticipating valve movement by indicating increases of output air pressure.

Step 5 Set travel

Increase the electrical control signal to the upper value (normally 20 mA or 10 V, but this depends on the application) and now check the travel of the valve. If required, slacken the central locking screw (see Figure 12) and adjust the slider up or down the upper or lower portion of the crescent shaped sector lever. Moving the slider away from the pivot will reduce the travel, and vice versa. Normally, except with 3-port valves, the fully open position is achieved before the valve plug hits the upper mechanical stop of the valve/actuator. Avoid settings of the positioner that allow contact with this mechanical stop. Vary the electrical control signal around the upper value to verify the travel setting, and if necessary repeat the adjustment of the slider until the required travel occurs at the upper value.

Important: Zero and travel settings on EP5 are not independent of each other, so re-check the zero setting as described in Step 4. It may prove necessary to repeat Steps 4 and 5 several times until acceptable zero and travel settings are achieved. For fine adjustment of the travel, the potentiometer shown in Figure 13 can be used. This should only be used for final adjustment of +/- 5%.

When complete, lock both zero and travel adjustments.

Travel adjustment potentiometer

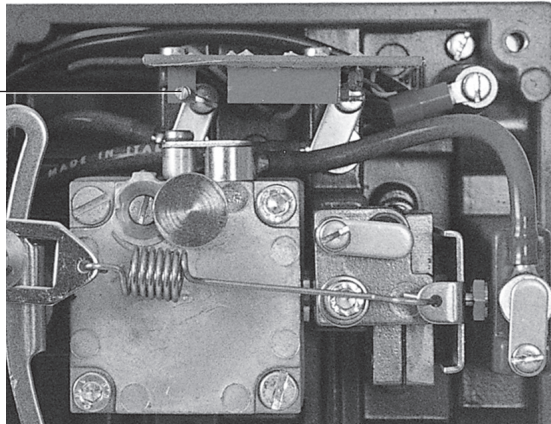

Fig. 13

Split range operation

EP5 may be split ranged to sequentially actuate two valves from one control signal (For example: valve 1 set to 4 - 12 mA and valve 2 set to 12 - 20 mA). Split ranging is achieved by adjustment of the zero and travel settings refer to Steps 4 and 5.

5. Maintenance

5.1 Regular maintenance

1. Drain any build-up within the air supply filter set as impurities such as oil, water and dirt will cause inconsistent operation.
2. Ensure air supply is at the correct pressure (see Section 3.3.2 and refer to actuator TI).
3. Make visual checks to ensure the valve is operating correctly.

5.2 Corrective maintenance

5.2.1 Removal and cleaning of sensitivity adjuster (see Figure 14):

- Loosen and remove lock.
- Note setting then remove sensitivity screw.
- Wash adjuster with solvent, checking condition of the cone and ensuring 0.35 mm side hole is clear.
- Dry with clean compressed air to ensure no remaining contaminants.
- Refit the cleaned adjuster and unscrew it 1 turn from its stop.

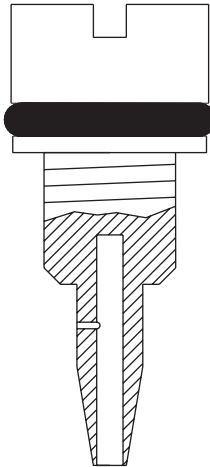

Fig. 14

- Refit the lock to touch the adjuster top and secure with lock-nut.
- Set sensitivity see Step 2, Section 4, Commissioning.
- Reset zero and span if required.

5.2.2 Removal and cleaning of capillary orifice (see Figure 15):

- Loosen locking plate screw.
- Rotate locking plate to expose capillary orifice.
- Using supplied extractor/cleaner pull the orifice from the body.
- Clean the small orifice and cross drilling using only the special cleaning wire supplied.
- Reassemble the orifice ensuring both 'O' rings are in place and the lock plate covers the orifice.

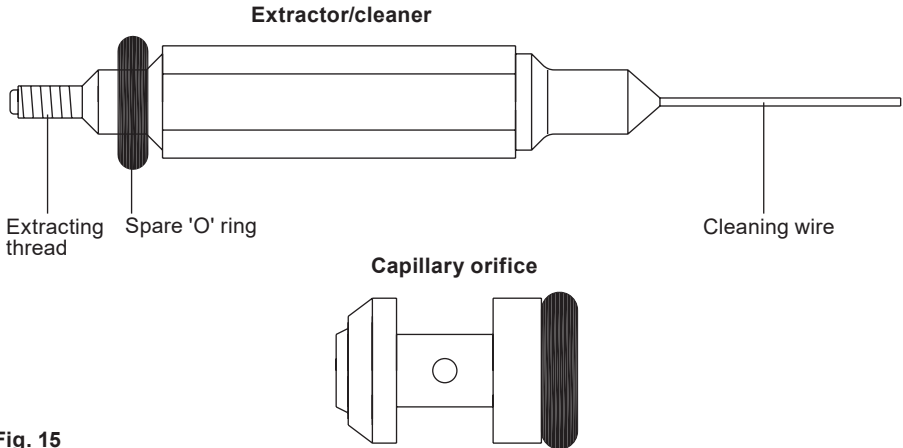

Fig. 15

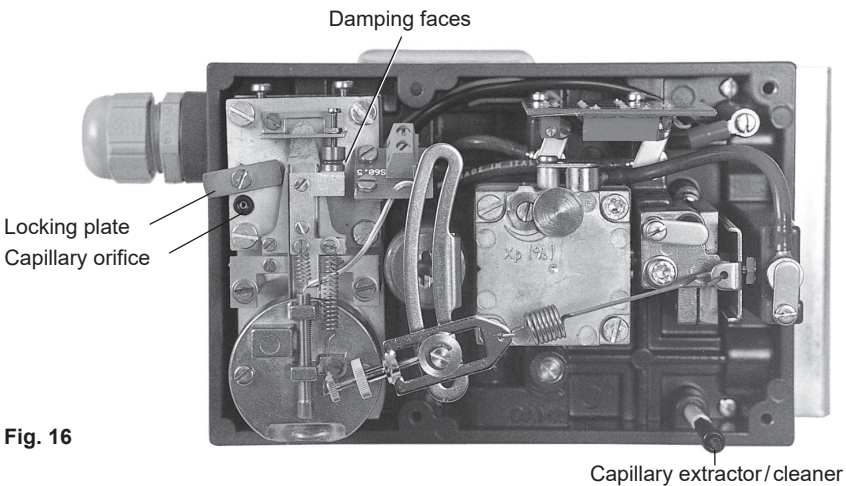

Fig. 16

Capillary extractor/cleaner

5.2.3 Check damping grease:

- Ensure gap of 1 mm exists between faces of damper. Adjust if necessary.
- Verify grease is present between faces.
- Replace grease if necessary (contact Spirax Sarco for details).

6. Spare parts

Available spares

Gauge block (without gauges)	1
Gauge 0 - 2 bar	2
Gauge 0 - 4 bar	3
Gauge 0 - 7 bar	4
Springs and tubes	5
Set of gaskets, diaphragms and orifice	6
Amplifying relay set	7

How to order spares and accessories

Always order spares by using the description in the column headed 'Available spares' and a description of the product, together with the TAG number.

Example: 1 off Gauge 0-2 bar for a Spirax Sarco EP5 positioner, TAG 907.

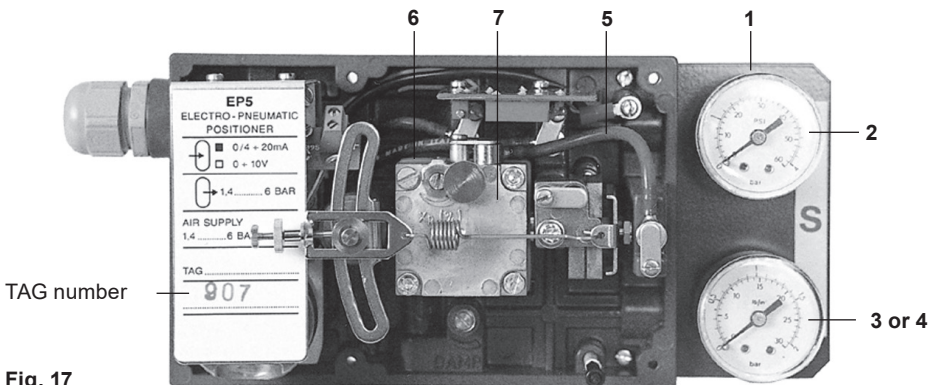

Fig. 17

Product return procedure

Please provide the following information with any equipment being returned:-

1. Your name, Company name, address and telephone number, order number and invoice and return delivery address.
2. Description of equipment being returned.
3. Description of the fault.
4. If the equipment is being returned under warranty, please indicate:
 - i. Date of purchase
 - ii. Original order number

Please return all items to:

Returns Investigations Department
Runnings Road,
Kingsditch Trading Estate
Cheltenham
Glos, GL51 9NX
United Kingdom

Alternatively, please return any items to your local Spirax Sarco branch.

Please ensure all items are suitably packed for transit (preferably in the original cartons).

7. Fault finding

Output pressure too low or zero

Cause	Remedy
a. No control signal	a. Restore mA signal
b. Low air supply pressure	b. Verify actuator air pressure requirement
c. Clogged or dirty sensitivity adjuster	c. Clean adjuster see Section 5.2.1
d. Clogged or dirty capillary orifice	d. Clean orifice see Section 5.2.2
e. Incorrect set-up	e. Recalibrate see Section 4, Steps 1 to 5
f. Damaged pneumatic actuator or piping	f. Verify replace as necessary
g. Port I not blanked or leaking	g. Insert ¼" NPT blank in port I

Output pressure too high

Cause	Remedy
a. Sensitivity adjuster open too far	a. Recalibrate see Section 4, Step 2

Actuator movement too slow

Cause	Remedy
a. Low air supply capacity	a. Check supply capacity and pipe sizes
b. Damping screw closed too far or clogged	b. Recalibrate see Section 4, Step 3

Actuator failing to close

Cause	Remedy
a. Output pressure too low	a. Refer to previous fault
b. Incorrect zero point	b. Recalibrate see Section 4, Step 4
c. Damping screw closed or clogged	c. Clean screw and recalibrate see Section 4, Step 3
d. Valve /actuator coupling incorrect	d. Reset (refer to valve/actuator IMIs)
e. Actuator too small	e. Fit correct actuator

Actuator failing to fully open valve

Cause	Remedy
a. Output pressure too low	a. Refer to previous fault
b. Incorrect travel adjustment	b. Recalibrate see Section 4, Step 5
c. Damping screw closed or clogged	c. Clean screw and recalibrate see Section 4, Step 3
d. Valve/actuator coupling incorrect	d. Reset (refer to valve/actuator IMIs)
e. Actuator too small	e. Fit correct actuator

Hunting

Cause	Remedy
a. Incorrect controller set up (P, I, and D)	a. Verify and adjust according to process requirement
b. Sensitivity orifice closed too far	b. Adjust by opening sensitivity screw see Section 4, Step 2
c. Excessive valve friction	c. Verify and maintain as valve IMI
d. Control valve over-sizing	d. Verify operating conditions against valve capacity.

Note: The effects of hunting caused by valve over-sizing or unstable process conditions can be reduced by adjustment of damping screw see Section 4, Step 3.

DICHIARAZIONE DI CONFORMITA' UE - N°RDEX002 Rev.00
EU DECLARATION OF CONFORMITY - N°RDEX002 Rev.00

<p>Spirax-Sarco S.r.l. Via per Cinisello 18, 20834 - Nova Milanese (MB) Italia, Con la presente dichiara che il prodotto sotto descritto, è stato sottoposto alla procedura di fabbricazione basata sulla Assicurazione della Qualità del Processo di produzione come da allegato IV della Direttiva Europea 2014/34/UE (ATEX). Hereby declares that the product below has been performed by fabrication procedure based on Quality Assurance Production Process as according to attach IV of European Directive 2014/34/EU (ATEX).</p> <p style="text-align: center;">II 2G Ex ib IIC T4 Gb</p>		
<p>POSIZIONATORE ELETTROPNEUMATICO ISP5 ELECTRO PNEUMATIC POSITIONER ISP5</p> <p><i>Lo strumento è destinato ad essere impiegato in atmosfere potenzialmente esplosive È stato progettato, costruito ed ispezionato secondo le seguenti normative</i></p> <p><i>The instrument is designed for use in potentially explosive atmospheres have been designed, manufactured and inspected according to the followings standards</i></p>		
<p>EN 60079-0: 2012, EN 60079-11: 2012</p>		
<p>che ottemperano ai requisiti richiesti dalla which comply with the requirements requested by</p>		
<p>Direttiva Europea 2014/34/UE (ATEX) European Directive 2014/34/EU (ATEX)</p>		

Fascicolo tecnico n° Technical Dossier n°	Numero dell'attestato UE di tipo EU type certificate number	NB (Ente notificato) NB (Notified Body)
RDEX002	0425 ATEX 002844-00	ICIM S.p.a. Via Don Enrico Mapelli 75 20099 Sesto San Giovanni Milano n° notifica 0425
Garanzia Qualità Produzione Quality Production Warranty	Numero di certificato di sistema Quality System Quality Certificate Number	NB (Ente notificato) NB (Notified Body)
Allegato IV Attachment IV	0425 ATEX 007894-00	ICIM S.p.a. Via Don Enrico Mapelli 75 20099 Sesto San Giovanni Milano n° notifica 0425

Nova Milanese, 21-04-2016

Il Direttore di Stabilimento

Plant Manager
 Giuseppe Villa

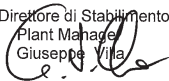



0425

Attestato di Esame CE del Tipo
EC-Type Examination Certificate

Certificato N. **0425 ATEX 002844-00**
 Certificate N.

In conformità a quanto prescritto dall'Al.3 della Direttiva 94/9/CE
 In compliance to what prescribed by the Annex 3 of the Directive 94/9/CE

ORGANISMO NOTIFICATO / NOTIFIED BODY

ICIM S.p.A. - Identification Number: 0425
 Piazza Don Enrico Mapelli, 75 - 20099 Sesto San Giovanni (MI) - ITALY

DATI FABBRICANTE / MANUFACTURER DETAILS

SPIRAX SARCO S.r.l.
 Via per Cinisello, 18
 20834 NOVA MILANESE (MB)

DATI PRODOTTO / PRODUCT DETAILS

PRODOTTO / PRODUCT **POSIZIONATORE ELETTRO-PNEUMATICO**
 MODELLO / MODEL **ISP5**
 CLASSIFICAZIONE / CLASSIFICATION **Vedi Allegato / See Annex**

EVENTUALI ESTENSIONI / EXTENSIONS
 //

ESAME CE DEL TIPO / EC TYPE EXAMINATION

L'esame è stato eseguito sul prodotto e sul Fascicolo Tecnico della Costruzione così identificato: "RDEX 002 REV.2" del 08/10/2015
 EC Type Examination has been conducted on product and relative Technical Construction File code: "RDEX 002 REV.2 on 08/10/2015"
 con esito **POSITIVO / with POSITIVE result**

Attestati di prova / Test Report – 195/Ex 051.00/03 e 195/Ex 051 .00 / 04

NOTE / NOTES

Rimane responsabilità del fabbricante dimostrare conformità ad altre Direttive applicabili al prodotto oggetto di questo certificato
 It remains the responsibility of the manufacturer to demonstrate conformity with other Directives applicable to the product described in this certificate.

Questo attestato è valido solo se gli esemplari sono identici ai modelli sopra indicati. Eventuali modifiche tecniche devono essere dichiarate ad ICIM che comunicherà come procedere / This certificate is valid only for the models above specified. Any technical change must be declared to ICIM S.p.A. that will give information how to proceed
 Il presente Certificato è da ritenersi valido solo se accompagnato dal relativo Allegato / This Certificate is valid only with the relative Annex

NOTE / NOTES
 --

ICIM S.p.A.

PRIMA EMISSIONE
 FIRST ISSUE
13/11/2015

EMISSIONE CORRENTE
 CURRENT ISSUE
13/11/2015

DATA DI SCADENZA
 EXPIRING DATE
12/11/2025

ICIM S.p.A. a socio unico - Piazza Don Enrico Mapelli, 75 - 20099 Sesto San Giovanni (MI)

0089CERT_00_IT



Attestato di Esame CE del Tipo
EC-Type Examination Certificate

ALLEGATO / ANNEX

Certificato N.
Certificate N.

0425 ATEX 002844-00

PRODOTTO PRODUCT	POSIZIONATORE ELETTRICO-PNEUMATICO
MODELLI MODELS	ISP5
CLASSIFICAZIONE CLASSIFICATION	 II 2G Ex Ib IIC T4 Gb -20°C < Ta < +80° C
NORME DI RIFERIMENTO REFERENCE STANDARDS	EN 60079-0:2012 EN 60079-11:2012
DOCUMENTI LISTATI SCHEDULED DOCUMENTS	Fascicolo Tecnico RDEX 002 REV.2 del 08/10/2015

ICIM S.p.A.

PRIMA EMISSIONE
FIRST ISSUE
13/11/2015

EMISSIONE CORRENTE
CURRENT ISSUE
13/11/2015

DATA DI SCADENZA
EXPIRING DATE
12/11/2025

ICIM S.p.A. a socio unico - Piazza Don Enrico Mapelli, 75 - 20099 Sesto San Giovanni (MI)

0068CCERT_00_IT



ICIM

**Attestato di Esame CE del Tipo
EC-Type Examination Certificate**

ALLEGATO / ANNEX

Certificato N.
Certificate N.

0425 ATEX 002844-00

DOCUMENTI CONSEGNATI (FASCICOLO TECNICO) DOCUMENTATION DELIVERED (TECHNICAL FILE)		
DESCRIZIONE DESCRIPTION	NUMERO E REVISIONE NUMBER AND REVISION	DATA DATE
DESCRIZIONE GENERALE DEL TIPO GENERAL TYPE DESCRIPTION	Cap.1 Fascicolo Tecnico RDEX 002 REV.2 del 08/10/2015	08/10/2015
DISEGNI DI PROGETTAZIONE E FABBRICAZIONE, SCHEMI DI COMPONENTI, SOTTOUNITÀ, CIRCUITI ETC. DESIGNAND MANUFACTURING DRAWING AND LAYOUTS OF COMPONENTS, SUB-ASSEMBLIES, CIRCUITS, ETC.	Cap.4 Fascicolo Tecnico RDEX 002 REV.2 del 08/10/2015	08/10/2015
DESCRIZIONE E SPIEGAZIONI NECESSARIE ALLA COMPRESIONE DI TALI DISEGNI E SCHEMI E AL FUNZIONAMENTO DEL PRODOTTO DESCRIPTION AND EXPLANATIONS NECESSARY FOR THE UNDERSTANDING OF SAID DRAWING AND LAYOUTS AND THE OPERATION OF THE PRODUCT	Cap.4 Fascicolo Tecnico RDEX 002 REV.2 del 08/10/2015	08/10/2015
RISULTATI DEI CALCOLI DI PROGETTO E DEGLI ESAMI RESULTS OF DESIGN CALCULATIONS MADE, EXAMINATIONS CARRIED OUT	Cap.1,11,12 Fascicolo Tecnico RDEX 002 REV.2 del 08/10/2015	08/10/2015
ELENCO DELLE NORME APPLICATE E DESCRIZIONE DELLE SOLUZIONI ADOTTATE PER SODDISFARE I REQUISITI DI SICUREZZA LIST OF THE STANDARDS REFERRED TO IN ARTICLE 5, ALLIED IN FULL	Cap.5 Fascicolo Tecnico RDEX 002 REV.2 del 08/10/2015	08/10/2015
RAPPORTI SULLE PROVE EFFETTUATE TEST REPORTS	Cap.11-12 Fascicolo Tecnico RDEX 002 REV.2 del 08/10/2015	08/10/2015
MANUALE D'USO MANUAL	Cap.9 Fascicolo Tecnico RDEX 002 REV.2 del 08/10/2015	08/10/2015
ANALISI DI RISCHIO RISK ANALYSIS	Cap. 3 Fascicolo Tecnico RDEX 002 REV.2 del 08/10/2015	08/10/2015
DICHIARAZIONE CE DI CONFORMITÀ EC DECLARATION OF CONFORMITY	Cap.13 Fascicolo Tecnico RDEX 002 REV.2 del 08/10/2015	08/10/2015

ICIM S.p.A.

PRIMA EMISSIONE
FIRST ISSUE
13/11/2015

EMISSIONE CORRENTE
CURRENT ISSUE
13/11/2015

DATA DI SCADENZA
EXPIRING DATE
12/11/2025

00688CERT_00_IT

ICIM S.p.A. a socio unico - Piazza Don Enrico Mapelli, 75 - 20099 Sesto San Giovanni (MI)

SERVICE

For technical support, please contact our local Sales Engineer or our Head Office directly:

Spirax Sarco S.r.l. - Technical Assistance

Via per Cinisello, 18 - 20834 Nova Milanese (MB) - Italy

Tel.: (+39) 0362 4917 257 - (+39) 0362 4917 211 - Fax: (+39) 0362 4917 315

E-mail: support@it.spiraxsarco.com

LOSS OF GUARANTEE

Total or partial disregard of above instructions involves loss of any rights to guarantee.

Spirax-Sarco S.r.l. - Via per Cinisello, 18 - 20834 Nova Milanese (MB) - Tel.: 0362 49 17.1 - Fax: 0362 49 17 307