

SP7/SP8 Mounting Kit Assembly

HARDWARE IDENTIFICATION		
A	LEVER 10-35 mm	ALK10 ONLY
B	LEVER 20-100 mm	ALK11/17 ONLY
C	LEVER 100-170 mm	AKL12 ONLY
D	SPACER	AKL17 ONLY
E	M8 x 16 lg HEX HEAD SCREW	AKL10/11/12 ONLY
F	M8 x 20 lg HEX HEAD SCREW	AKL17 ONLY
G	U-BOLT	UBC ONLY (ORDERED SEPARATELY)
P	BRACKET	ALL KITS
Q	FOLLOWER PIN ASSEMBLY	
R	FOLLOWER GUIDE ASSEMBLY	
S	M8 HEX HEAD SCREW	
U	M8 SPRING WASHER	
V	M8 PLAIN WASHER	
W	M8 NUT	

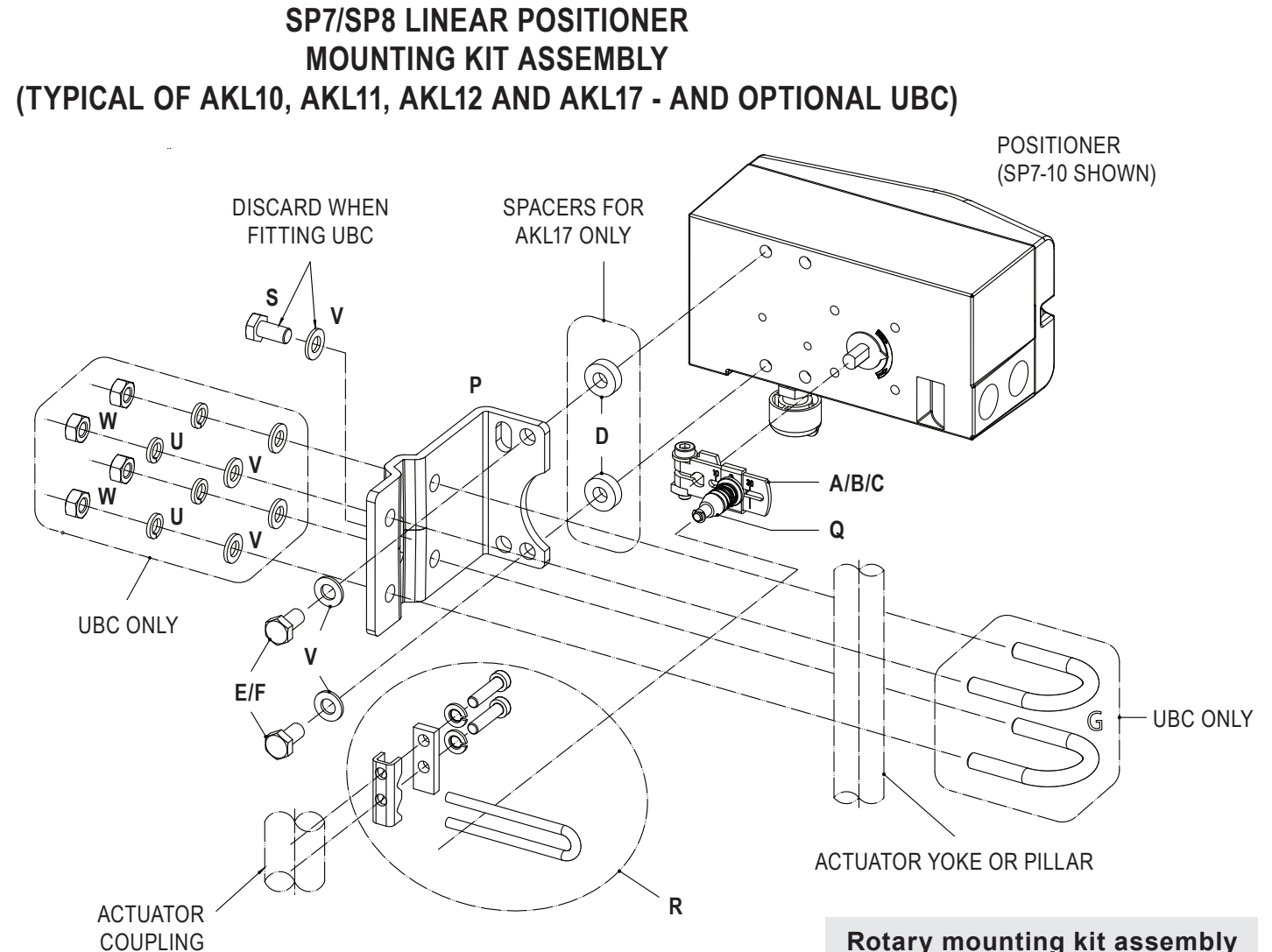

**Rotary mounting kit assembly
is shown overleaf**

SP7/SP8 ROTARY POSITIONER MOUNTING KIT ASSEMBLY (TYPICAL OF AKR13, AKR14, AKR15 AND AKR16)

NOTE SHAFT POSITION:
POSITION SHOWN IS TO SUIT
BVA300 ACTUATORS.
GRUB SCREW TO LOCATE ON FLAT

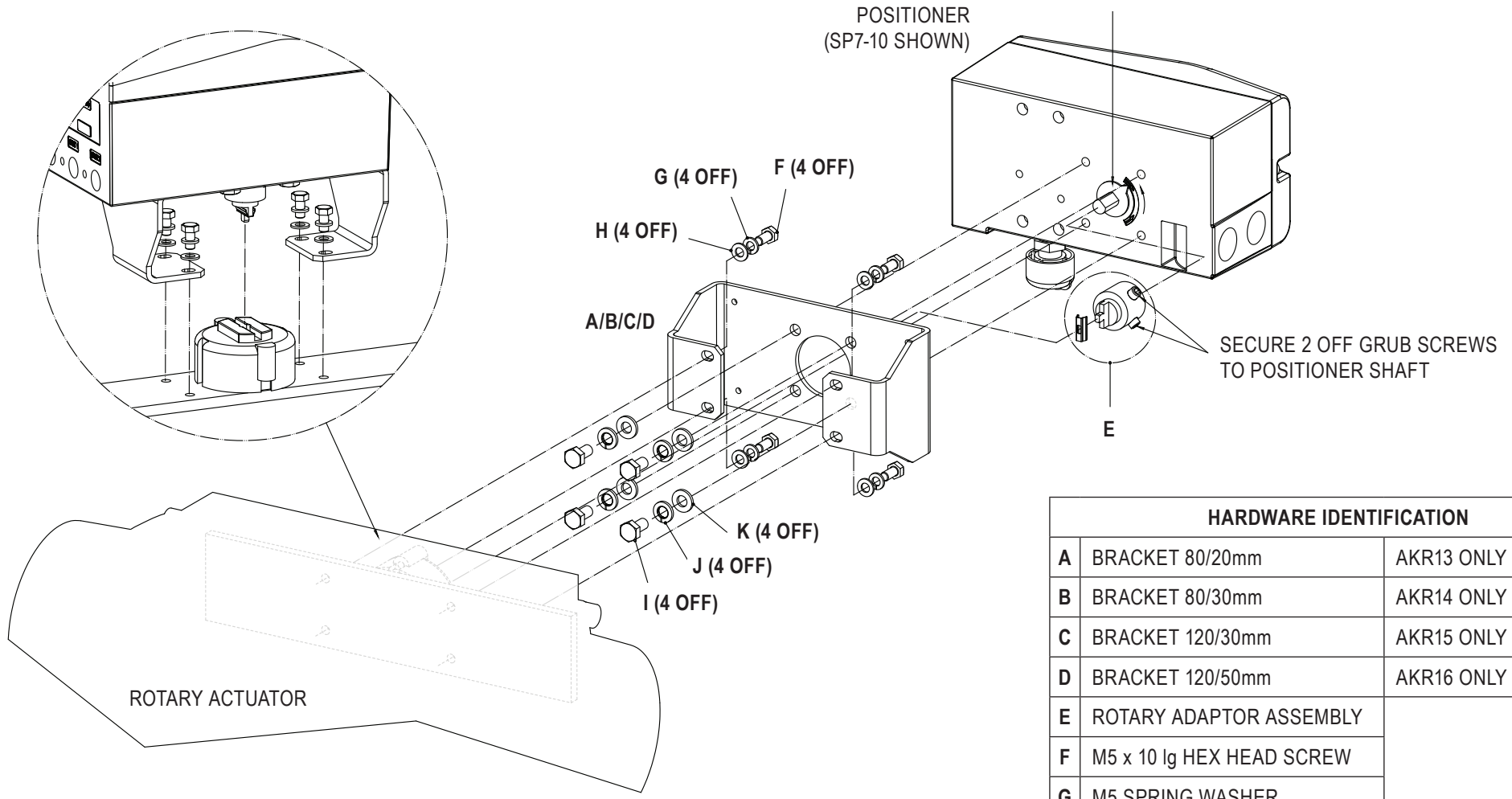

HARDWARE IDENTIFICATION		
A	BRACKET 80/20mm	AKR13 ONLY
B	BRACKET 80/30mm	AKR14 ONLY (SHOWN)
C	BRACKET 120/30mm	AKR15 ONLY
D	BRACKET 120/50mm	AKR16 ONLY
E	ROTARY ADAPTOR ASSEMBLY	ALL KITS
F	M5 x 10 lg HEX HEAD SCREW	
G	M5 SPRING WASHER	
H	M5 PLAIN WASHER	
I	M6 x 12 lg HEX HEAD SCREW	
J	M6 SPRING WASHER	
K	M6 PLAIN WASHER	