

## PP6 Positioner

### Quick Start Guide

---

---



This guide covers only a brief description of installation and maintenance for Spiratrol and QL valves. For detailed installation, operations, maintenance including safety, precautions, and warnings, please refer to our official instruction manual at [www.spiraxsarco.com](http://www.spiraxsarco.com) (IM-P704-02).

PP6 is Pneumatic-Pneumatic Positioner that accurately controls valve stroke in response to a pneumatic input signal of 0.02~0.1 MPa (0.2~1 bar) from the controller.

**! NOTE: Use of the positioner in a hazardous area.**

- 1 The positioner must be suitably earthed to prevent static electricity
- 2 Operation with air hotter than 70 °C is to be avoided
- 3 The positioner must not be used in a Zone 0 area.
- 4 Only wipe the positioner with a damp cloth to prevent static build up.

# 1. Installation

## 1.1 Linear positioner

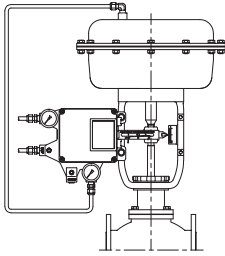

Side view shown for clarity

1.1.3 Make sure that Positioner's feedback lever is perpendicular to the valve stem at 50% of the valve stroke.

1.1.4 The feedback pin coming from the actuator coupling should be inserted inside slot of the feedback lever in such a way that the length of valve stroke coincides with the corresponding figures in "mm" marked on the feedback lever. Improper setting may cause poor linearity or damage to positioner.

1.1.1 Assemble feedback pin locator and feedback pin to actuator coupling firmly.

Mounting Positions	Pin Locator Marking	Valve stroke	MTG kit	Feedback pin locator direction
Central	N/A	20	PY1	←
		30		
		50	PY2	
		70		
Left hand side	D	20	UY3	←
	A	30		
	B	50	UY1	→
	E	70		

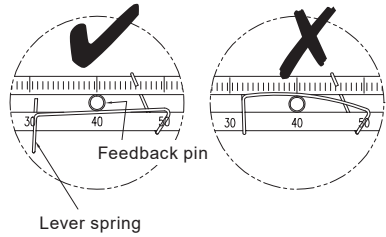

1.1.5 At 0% or 100% position, the linear lever or linear lever stopper should not touch the stopping bosses of positioner.

1.1.6 As a final step, tighten the bracket to the actuator yoke.

1.1.2 Assemble the supplied feedback lever and bracket to positioner firmly, then loosely mount the assembly on the left hand side of the actuator yoke. For central mount, mount on the right hand side of the actuator yoke.

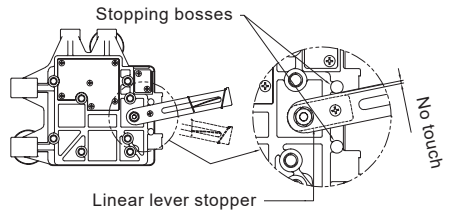
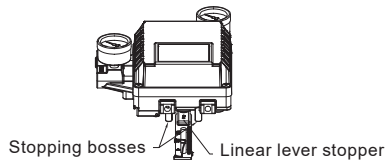
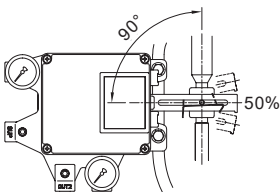

# 1.2 Rotary positioner

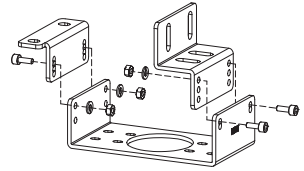
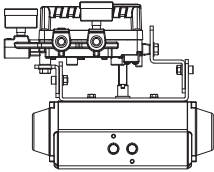

1.2.1 There are three brackets in the positioner box.

1.2.2 Refer to the figure and check the bolting positions of the upper and lower brackets to be fastened depending on the actuator's stem height. And then assemble the positioner with the brackets by using M6 bolts, washers and nuts.

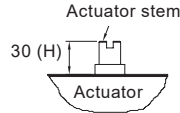

1.2.3 Make sure that the center of positioner's main shaft is well aligned with the center of actuator's stem.

1.2.4 Tighten the positioner and bracket, taking into account the alignment described in step 3 above.

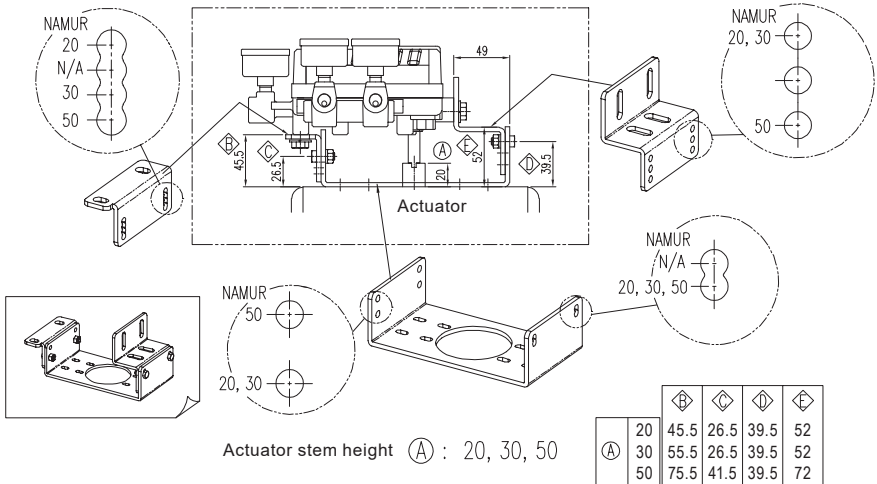

# 2. Connection – Air

## 2.1 Single acting actuator (side mount positioner)

### 2.1.1 Piping and span direction setting for linear DA single actuator

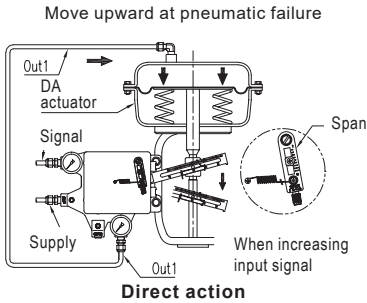

**Note: For central mount, reverse Span lever**

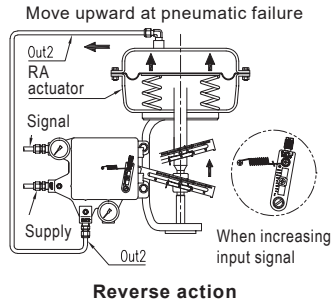

**Note: For central mount reverse the Span lever**

### 2.1.2 Piping and span direction setting for linear RA single actuator

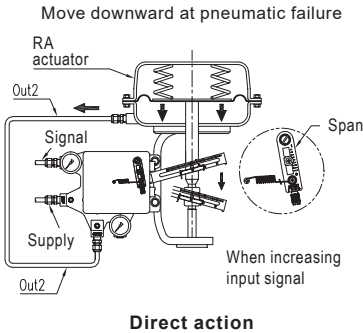

**Note: For central mount reverse the Span lever**

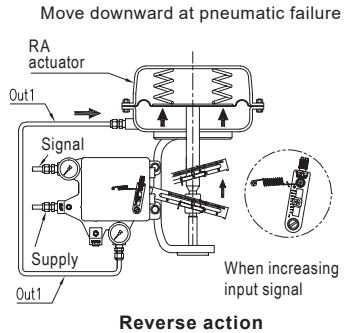

**Note: For central mount reverse the Span lever**

### 2.1.3 Piping and cam direction setting for rotary single actuator

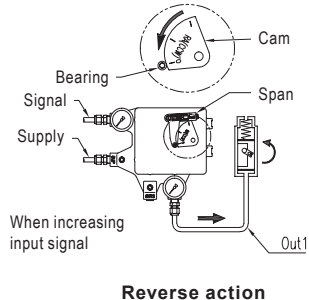
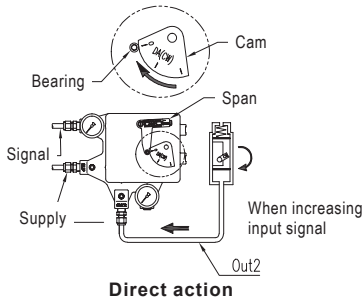

## 2.2 Double acting actuator (side mount positioner)

### 2.2.1 Piping and 'Span' direction setting for linear double actuator

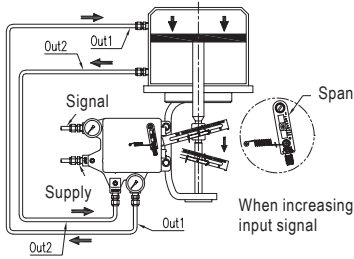

**Direct action**

**Note: For central mount reverse the Span lever**

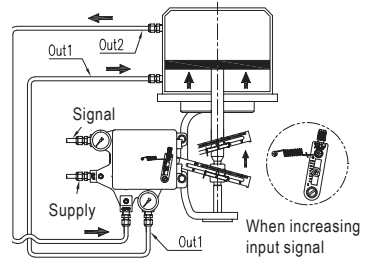

**Reverse action**

**Note: For central mount reverse the Span lever**

### 2.2.2 Piping and cam direction setting for rotary double actuator

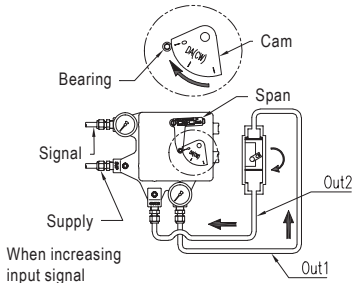

**Direct action**

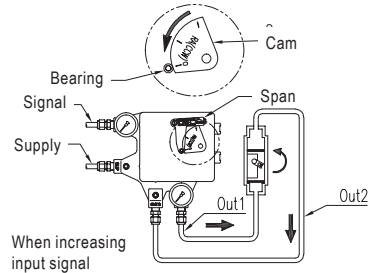

**Reverse action**

# 3. Adjustments

## 3.1 Adjustment - Zero Point

Set input signal pressure at 0.02MPa (or 0.1MPa) as the initial signal and rotate the adjust wheel of zero setting unit upward or downward to set actuator's zero point. Please refer to the figure opposite.

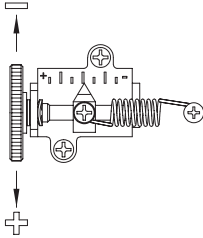

## 3.2 Adjustment - Span

3.2.1 After setting zero point, supply input signal pressure at 0.1MPa (or 0.02MPa) as the end point pressure and check the actuator stroke. If the stroke is low, the span should be stretched. If the stroke is high, the span should be reduced.

3.2.2 Changing span will affect zero point setting so zero point should be set again after span has been adjusted.

3.2.3 Above two steps are required several times until both zero and span are properly set.

3.2.4 After proper setting, tighten lock screw of the span unit.

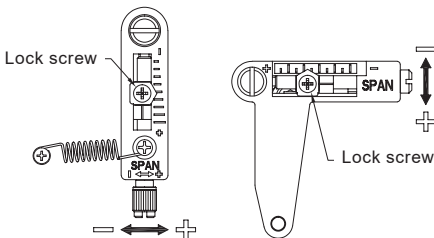

## 3.3 Adjustment – A/M switch (Auto/Manual)

3.3.1 Auto manual switch is located on the top of pilot unit. Auto manual switch allows the positioner to be functioned as bypass.

If the switch is rotated counterclockwise (toward "M", Manual), then the supply pressure will be directly supplied to the actuator regardless of input signal. On the other hand, if the switch is turned clockwise (toward "A", Auto), then the positioner will operate normally by input signal.

3.3.2 Make sure that the supply pressure does not exceed the rated pressure level of the actuator before the switch is loosened toward "M".

3.3.3 After using the "Manual" function, return the auto manual switch to "Auto".

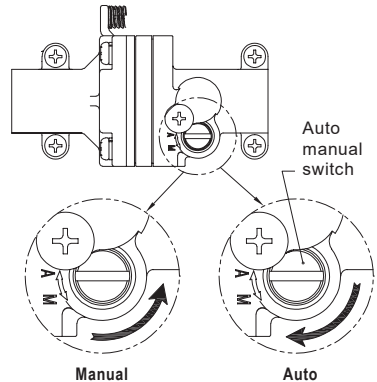

# 8. Approvals

## Declaration of Conformity

spiraxsarco.com

**spirax**  
**sarco** EN

### EU DECLARATION OF CONFORMITY

Apparatus model/Product: **Pneumatic Positioner  
PP6**

Name and address of the manufacturer or his  
authorised representative: **Spirax Sarco Ltd,**  
Runnings Road  
Cheltenham  
GL51 9NQ  
United Kingdom

This declaration of conformity is issued under the sole responsibility of the manufacturer.

The object of the declaration described above is in conformity with the relevant Union harmonisation legislation:

2014/34/EU ATEX Directive

References to the relevant harmonised standards used or references to the other technical specifications in relation to which conformity is declared:

ATEX Directive EN 1127-1:2019  
EN ISO 80079-36:2016  
EN ISO 80079-37:2016

Additional information:

ATEX coding: II 2GD Ex h IIC T6 Gb  
Ex h IIIC T85°C Db

On behalf of: Spirax Sarco Ltd,

(name, function): M Sadler  
Steam Business Development Engineering  
Product Integrity & Compliance Manager

(place and date of issue): Cheltenham

2021-06-24

# Declaration of Conformity (continued)

spiraxsarco.com



## DECLARATION OF CONFORMITY

Apparatus model/Product: **Pneumatic Positioner  
PP6**

Name and address of the manufacturer or his authorised representative: **Spirax Sarco Ltd,**  
Runnings Road  
Cheltenham  
GL51 9NQ  
United Kingdom

This declaration of conformity is issued under the sole responsibility of the manufacturer.

The object of the declaration described above is in conformity with the relevant statutory requirements of:

**SI 2016 No.1107 \*    The Equipment and Protective Systems Intended for Use in  
Potentially Explosive Atmospheres Regulations 2016**

(\*As amended by EU Exit Regulations)

References to the relevant designated standards used or references to the other technical specifications in relation to which conformity is declared:

**SI 2016 No.1107 \***    EN 1127-1:2019  
                                  EN ISO 80079-36:2016  
                                  EN ISO 80079-37:2016

Additional information:

Explosion proof coding:  II 2GD Ex h IIC T6 Gb  
                                  Ex h IIC T85°C Db

On behalf of:    Spirax Sarco Ltd,

(name, function):    M Sadler  
                                  Steam Business Development Engineering  
                                  Product Integrity & Compliance Manager

(place and date of issue):    Cheltenham

09 August 2021