PN7000 and PN8000 Pneumatic Actuators Installation and Maintenance Instructions

The PED Directive 97/23/EC is repealed and replaced by the new
PED Directive 2014/68/EU with effect from 19 July 2016.

The ATEX Directive 94/9/EC is repealed and replaced by the new
ATEX Directive 2014/34/EU with effect from 20 April 2016.

1. *PN7000 -
General information*
2. *PN8000 -
General information*
3. *Installation*
4. *Commissioning*
5. *Spare parts*
6. *Maintenance*

ATTENZIONE

Lavorare in sicurezza con apparecchiature in ghisa e vapore

Working safely with cast iron products on steam

Informazioni di sicurezza supplementari - *Additional Informations for safety*

Lavorare in sicurezza con prodotti in ghisa per linee vapore

I prodotti di ghisa sono comunemente presenti in molti sistemi a vapore.

Se installati correttamente, in accordo alle migliori pratiche ingegneristiche, sono dispositivi totalmente sicuri.

Tuttavia la ghisa, a causa delle sue proprietà meccaniche, è meno malleabile di altri materiali come la ghisa sferoidale o l'acciaio al carbonio.

Di seguito sono indicate le migliori pratiche ingegneristiche necessarie per evitare i colpi d'ariete e garantire condizioni di lavoro sicure sui sistemi a vapore.

Movimentazione in sicurezza

La ghisa è un materiale fragile: in caso di caduta accidentale il prodotto in ghisa non è più utilizzabile. Per informazioni più dettagliate consultare il manuale d'istruzioni del prodotto.

Rimuovere la targhetta prima di effettuare la messa in servizio.

Working safely with cast iron products on steam

Cast iron products are commonly found on steam and condensate systems.

If installed correctly using good steam engineering practices, it is perfectly safe.

However, because of its mechanical properties, it is less forgiving compared to other materials such as SG iron or carbon steel.

The following are the good engineering practices required to prevent waterhammer and ensure safe working conditions on a steam system.

Safe Handling

Cast iron is a brittle material. If the product is dropped during installation and there is any risk of damage the product should not be used unless it is fully inspected and pressure tested by the manufacturer.

Please remove label before commissioning

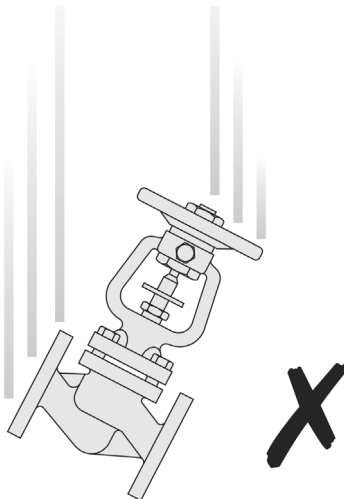

Prevenzione dai colpi d'ariete - *Prevention of water hammer*

Scarico condensa nelle linee vapore - *Steam trapping on steam mains:*

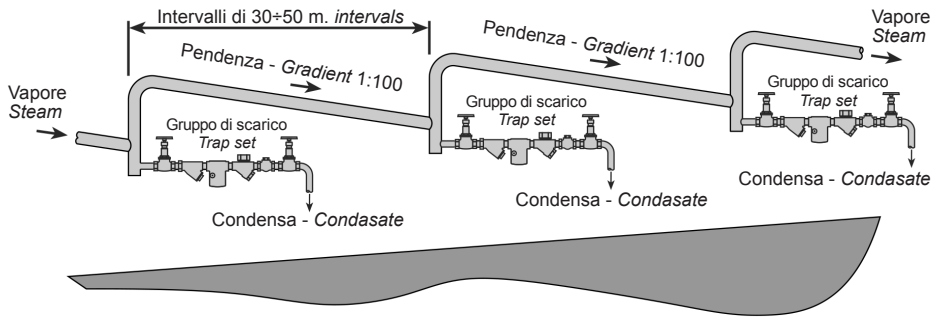

Esempi di esecuzioni corrette (✓) ed errate (✗) sulle linee vapore: *Steam Mains - Do's and Don't's:*

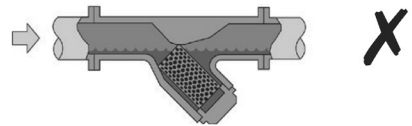
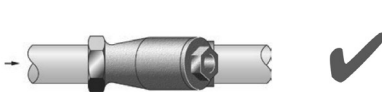
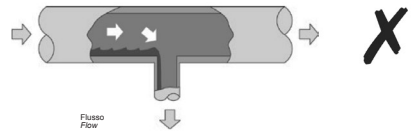
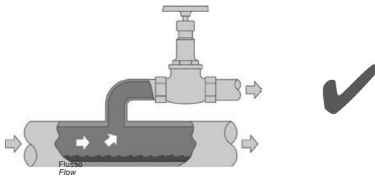
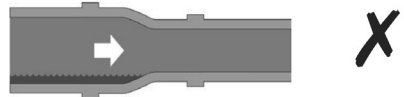
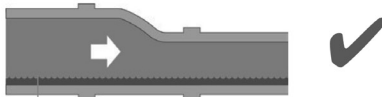
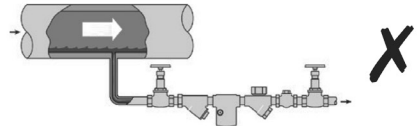
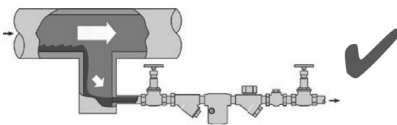

Prevenzione delle sollecitazioni di trazione

Prevention of tensile stressing

Evitare il disallineamento delle tubazioni - *Pipe misalignment*:

Installazione dei prodotti o loro rimontaggio post-manutenzione:

Installing products or re-assembling after maintenance:

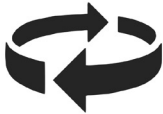

Evitare l'eccessivo serraggio.
Utilizzare le coppie di serraggio
raccomandate.

*Do not over tighten.
Use correct torque figures.*

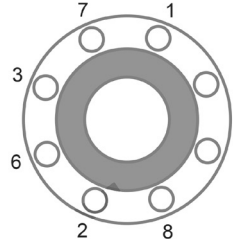
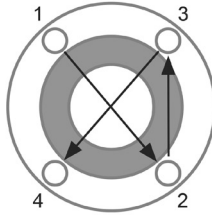

Per garantire l'uniformità del carico e dell'allineamento,
i bulloni delle flange devono essere serrati in modo
graduale e in sequenza, come indicato in figura.

*Flange bolts should be gradually tightened across
diameters to ensure even load and alignment.*

Dilatazioni termiche - *Thermal expansion:*

Gli esempi mostrano l'uso corretto dei compensatori di dilatazione. Si consiglia di richiedere una consulenza specialistica ai tecnici dell'azienda che produce i compensatori di dilatazione.

Examples showing the use of expansion bellows. It is highly recommended that expert advise is sought from the bellows manufacturer.

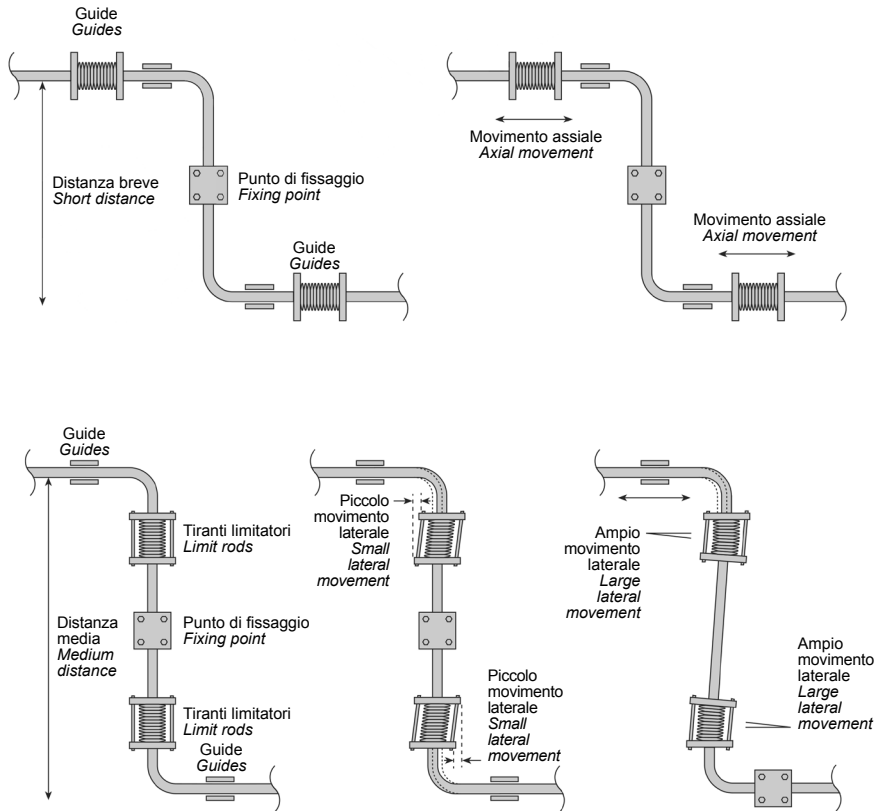

— 1. PN7000 - General information —

PN7000 series, spring extend pneumatic actuators

Available types

Spring extend spindle, single spring, yoke mounted actuators: PN7200, PN7300, PN7400, PN7500, and PN7600 series.

Description

A range of compact linear actuators having 5 diaphragm sizes for matching the requirements of different valves at various differential pressures. Each actuator is fitted with a stroke indicator and incorporates a semi-rolling diaphragm which gives good linearity over the operating stroke. These actuators are designed to operate with 2-port KE and 3-port QL valves as detailed below.

Actuator type	Valve type
20 mm travel	KE and QL series DN15 - DN50
30 mm travel	KE and QL series DN65 - DN100
50 mm travel	KE and QL series DN125 - DN200

Technical data

Temperature range	-20° to +100°C
Maximum operating pressure	2.5 bar g

Air supply connection

Actuator type	Connection
PN7200 to PN7600 series	1/4" NPT

Actuator capacities

Actuator type	Travel	Volume (Litres)
PN7200 series	20 mm	0.6
	30 mm	1.0
PN7300 series	20 mm	1.4
	30 mm	2.1
PN7400 series	20 mm	2.4
	30 mm	3.6
PN7500 series	20 mm	3.8
	30 mm	5.7
PN7600 series	30 mm	5.7
	50 mm	8.5

Spring ranges

Actuator type		Spring range	Travel
PN7200 series	PN7220	0.2 (0.4) to 1 (1.2) bar	20 mm
	PN7225	0.4 to 2 bar	20 mm
PN7300 series	PN7320	0.2 (0.4) to 1 (1.2) bar	20 mm
	PN7325	0.4 to 2 bar	20 mm
PN7400 series	PN7420	0.2 (0.4) to 1 (1.2) bar	20 mm
	PN7425	0.4 to 2 bar	20 mm
	PN7430	0.2 (0.4) to 1 (1.2) bar	30 mm
	PN7435	0.4 to 2 bar	30 mm
PN7500 series	PN7520	0.2 (0.4) to 1 (1.2) bar	20 mm
	PN7525	0.4 to 2 bar	20 mm
	PN7530	0.2 (0.4) to 1 (1.2) bar	30 mm
	PN7535	0.4 to 2 bar	30 mm
PN7600 series	PN7620	0.2 (0.4) to 1 (1.2) bar	20 mm
	PN7625	0.4 to 2 bar	20 mm
	PN7630	0.2 (0.4) to 1 (1.2) bar	30 mm
	PN7635	0.4 to 2 bar	30 mm
	PN7650	0.2 (0.4) to 1 (1.2) bar	50 mm
	PN7655	0.4 to 2 bar	50 mm

Materials

No Part	Material
1 Diaphragm housing	Pressed steel
2 Diaphragm	Reinforced nitrile rubber
3 Diaphragm plate	Cast iron
4 Spring	Spring steel
5 Spindle	Stainless steel
6 Lock-nut	Zinc plated steel
7 'O' Ring	Rubber
8 Spring setting nut	Zinc plated steel
9 Spring holder	Cast iron
10 Fixing screws	Steel
11 Spacer	Zinc plated steel
12 Travel indicator	Aluminium
13 Yoke	Cast iron
14 Gasket	Non asbestos fibre
15 Cap (with vent hole)	Plastic
16 Housing (bolts and nuts)	Steel
17 Top adaptor	Steel
18 Lock-nut	Steel
19 Bottom adaptor	Steel
20 Connectors	Stainless steel
21 Connectors (bolts and nuts)	Stainless steel

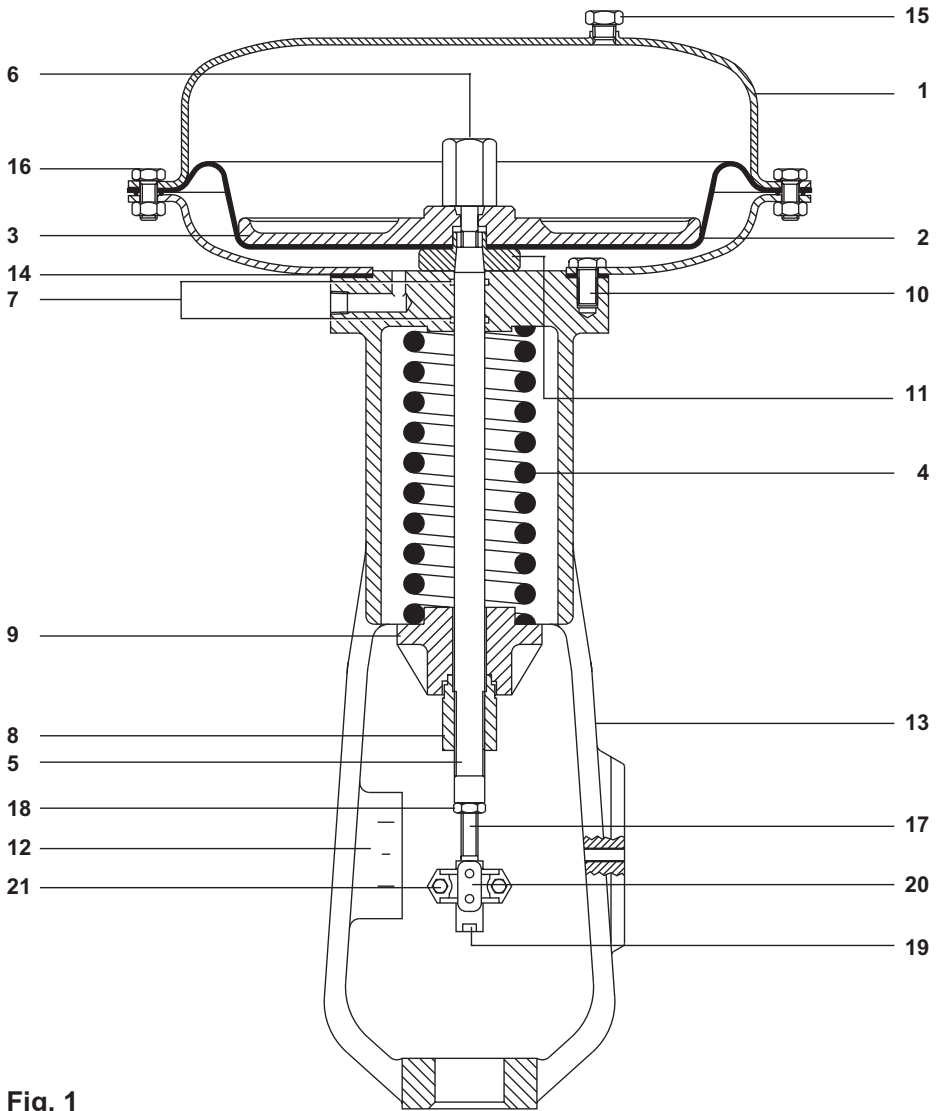

Fig. 1

— 2. PN8000 - General information —

PN8000 series, spring retract pneumatic actuators

Available types

Spring retract spindle, single spring, yoke mounted actuators: PN8200, PN8300, PN8400, PN8500, and PN8600 series.

Description

A range of compact linear actuators having 5 diaphragm sizes for matching the requirements of different valves at various differential pressures. Each actuator is fitted with a stroke indicator and incorporates a semi-rolling diaphragm which gives good linearity over the operating stroke. These actuators are designed to operate with 2-port KE and 3-port QL valves as detailed below.

Actuator type	Valve type
20 mm travel	KE and QL series DN15 - DN50
30 mm travel	KE and QL series DN65 - DN100
50 mm travel	KE and QL series DN125 - DN200

Technical data

Temperature range	-20° to +100°C
Maximum operating pressure	2.5 bar g

Air supply connection

Actuator type	Connection
PN8200 to PN8600 series	¼" NPT

Actuator capacities

Actuator type	Travel	Volume (Litres)
PN8200 series	20 mm	0.6
	30 mm	1.0
PN8300 series	20 mm	1.4
	30 mm	2.1
PN8400 series	20 mm	2.4
	30 mm	3.6
PN8500 series	20 mm	3.8
	30 mm	5.7
PN8600 series	30 mm	5.7
	50 mm	8.5

Spring ranges

Actuator type		Spring range	Travel
PN8200 series	PN8220	0.2 to 1 bar	20 mm
	PN8225	0.4 to 2 bar	20 mm
PN8300 series	PN8320	0.2 to 1 bar	20 mm
	PN8325	0.4 to 2 bar	20 mm
PN8400 series	PN8420	0.2 to 1 bar	20 mm
	PN8425	0.4 to 2 bar	20 mm
	PN8430	0.2 to 1 bar	30 mm
	PN8435	0.4 to 2 bar	30 mm
PN8500 series	PN8520	0.2 to 1 bar	20 mm
	PN8525	0.4 to 2 bar	20 mm
	PN8530	0.2 to 1 bar	30 mm
	PN8535	0.4 to 2 bar	30 mm
PN8600 series	PN8620	0.2 to 1 bar	20 mm
	PN8625	0.4 to 2 bar	20 mm
	PN8630	0.2 to 1 bar	30 mm
	PN8635	0.4 to 2 bar	30 mm
	PN8650	0.2 to 1 bar	50 mm
	PN8655	0.4 to 2 bar	50 mm

Materials

No	Part	Material
1	Diaphragm housing	Pressed steel
2	Diaphragm	Reinforced nitrile rubber
3	Diaphragm plate	Cast iron
4	Spring	Spring steel
5	Spindle	Stainless steel
6	Lock-nut	Zinc plated steel
8	Spring setting nut	Zinc plated steel
9	Spring holder	Cast iron
10	Fixing screws	Steel
12	Travel indicator	Aluminium
13	Yoke	Cast Iron
14	Gasket	Non asbestos fibre
15	Cap (with vent hole)	Plastic
16	Housing (bolts and nuts)	Steel
17	Top adaptor	Steel
18	Lock-nut	Steel
19	Bottom adaptor	Steel
20	Connectors	Stainless steel
21	Connectors (bolts and nuts)	Stainless steel

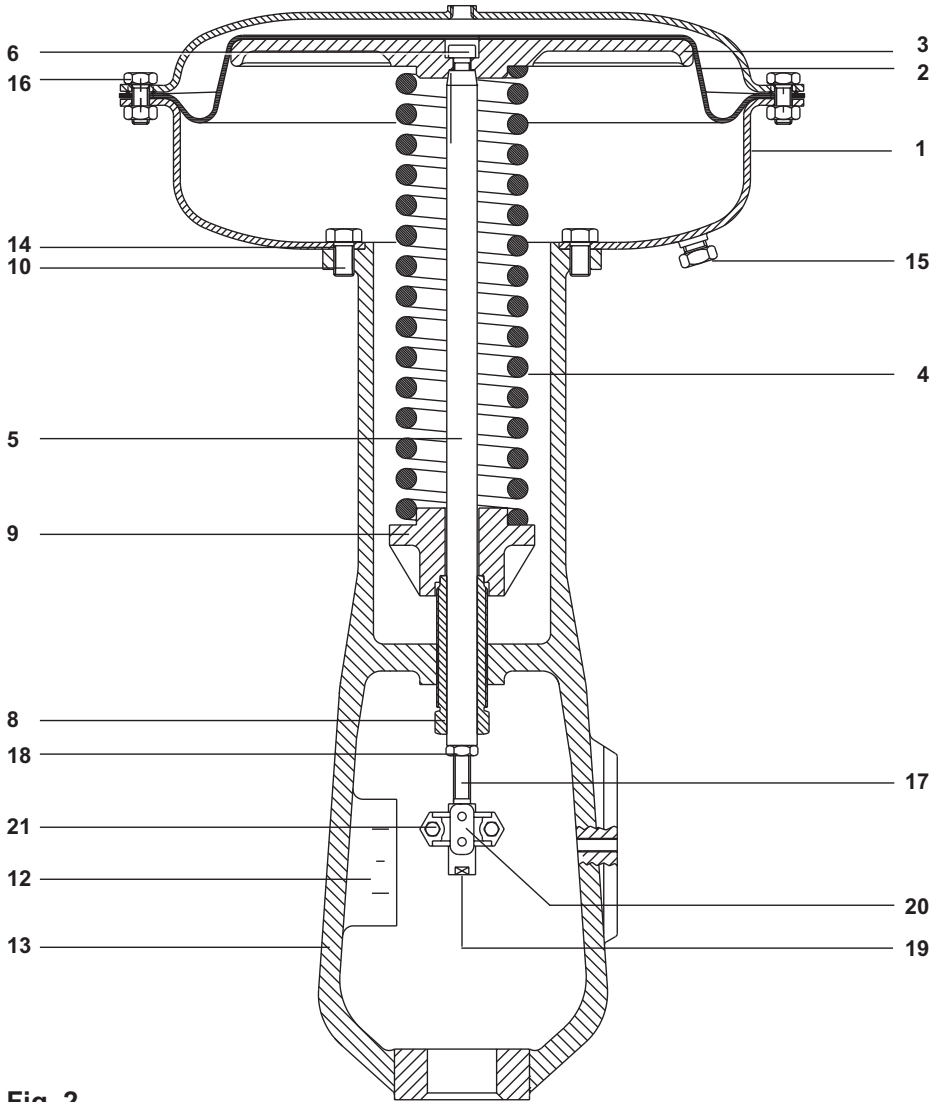

Fig. 2

3. Installation

See also separate Installation and Maintenance Instructions for the control valves.

The actuators should be installed in such a position as to allow full access to both actuator and valve for maintenance purposes. The preferred mounting position is with the actuator and valve spindle in the vertical position above or below the horizontal pipework.

The actuator ambient limits are -20°C to +100°C. For low temperature conditions the air supply must be dry. For high temperature conditions, insulate the control valve and pipework to protect the actuator.

Warning

The actuator housing must only be pressurized on the opposite side of the diaphragm to the springs. The housing vent cap must be left unrestricted.

2.1 Fitting the actuator to the valve

PN7000 (refer to figures 3a, 3b and 3c)

Loosen and remove connectors locking screws and nuts (21) and remove connectors (20). Fit the valve spindle adaptor (19) onto the valve spindle and push the valve plug manually to its closed position.

Adjust the distance of the adaptor (19) from the bonnet shoulder at the value indicated in Table 1.

Apply the control signal pressure required to bring the spindle to the mid-travel position.

Place actuator yoke over valve spindle and locate on bonnet shoulder. Locate and tighten valve mounting nut to the right torque (see Table 1).

Release the control air signal. Fit the connectors (20) across the adaptors (17) and (19).

Fit connectors locking screws and nuts (21) and tighten to 2 N m.

Follow the spring adjust procedure as described in Section 4.

PN8000 (Refer to figures 3a, 3b and 3c)

Loosen and remove connector locking screws and nuts (21) and remove connector (20).

Fit the valve spindle adaptor (19) onto the valve spindle and push the valve plug manually to its closed position.

Adjust the distance of the adaptor (19) from the bonnet shoulder at the value indicated in Table 1.

Place actuator yoke over valve spindle and locate on bonnet shoulder. Locate and tighten valve mounting nut to the right torque (see Table 1).

Apply the control air signal to bring the actuator spindle against the valve spindle.

Fit the connector (20) across the adaptors (17) and (19).

Fit connector locking screws and nuts (21) and tighten to 2 N m. Release the control air signal.

Follow the spring adjust procedure as described in Section 4.

Table 1 refer to figure 3a

Actuator type	Travel	Dimension 'A' (mm)	Mounting nut Size	Mounting size tightening torque (N m)
PN7200 series	20 mm	100	M30	15 - 20
PN7300 series	20 mm	100	M30	15 - 20
PN7400 series	20 mm	130	M30	15 - 20
	30 mm	140	M50	45 - 50
PN7500 series	20 mm	140	M30	15 - 20
	30 mm	150	M50	45 - 50
PN7600 series	20 mm	140	M30	15 - 20
	30 mm	150	M50	45 - 50
	50 mm	150	M70	65 - 70

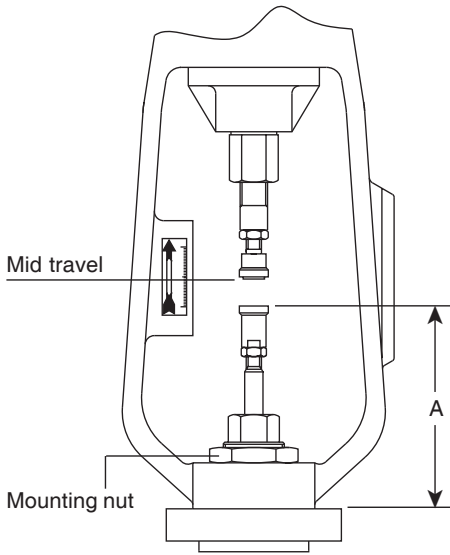

Fig. 3a

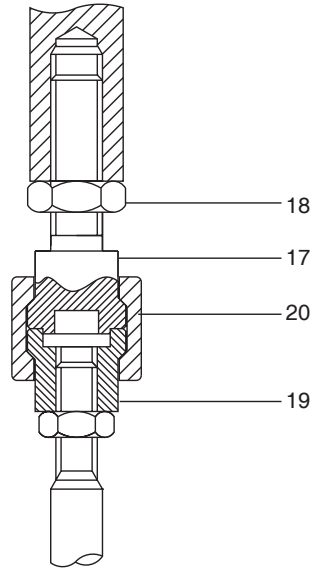

Fig. 3b

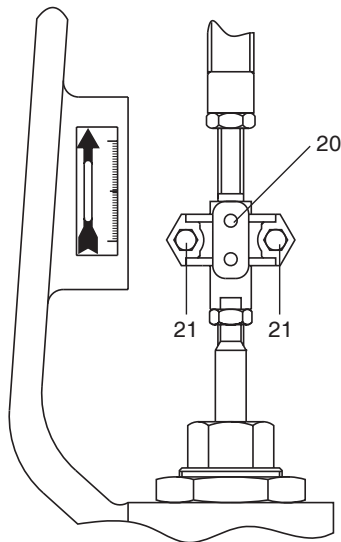

Fig. 3c

4. Commissioning

If the actuator/valve has been supplied with a positioner, reference should be made to the separate Installation and Maintenance Instructions for this product.

4.1 Adjusting spring

The actuator spring range and lift off pressure will be indicated on the nameplate. Should it be necessary to check or adjust the lift off pressure the procedure is described in paragraphs 4.2 and 4.3.

Important

To prevent damage to the valve seat, please ensure the plug does not turn while pressing on the seat during assembling or adjustment.

To prevent damage to the diaphragm ensure the actuator spindle is not allowed to rotate when the diaphragm is assembled within its housing.

4.2 PN7000 spring extend actuators

Note: Adjustment of the spring will only alter the pressure of the control signal air at which the valve commences to move off its seat (set point) and will not alter the spring pressure range required to move the valve through its full travel. i.e. 0.2 to 1.0 bar spring (range 0.8 bar) set to commence to lift at 0.4 bar will require a 1.2 bar air pressure (0.4 + 0.8) to obtain valve full travel.

To adjust set point refer to fig. 1 and proceed as follows:-

Ensure the control valve has been isolated and the actuator housing is pressure free.

Increase the control signal pressure until the actuator commences lifting the actuator spindle. Check whether the signal pressure corresponds to the desired starting value.

Release completely the air signal pressure.

Tighten (loosen) slightly the spring set nut to increase (decrease) the actual signal pressure starting value.

Recheck that the valve just commences to move off its seat at the right spring range minimum pressure and is fully open at the spring range maximum pressure.

After the test check the position of the travel indicator against the "arrow" of the connector and adjust its position accordingly.

4.3 PN8000 spring retract actuators

Note: Adjustment of the spring will only alter the pressure of the control signal air at which the valve commences to move off its seat (set point) and will not alter the spring pressure range required to move the valve through its full travel. i.e. 0.2 to 1.0 bar spring (range 0.8 bar) set to commence to lift at 0.4 bar will require a 1.2 bar air pressure (0.4 + 0.8) to obtain valve full travel.

To adjust set point refer to fig. 2 and proceed as follows:-

Ensure the control valve has been isolated and the actuator housing is pressure free.

Apply the control signal pressure required to complete the full travel of the actuator spindle.

Check whether the signal pressure corresponds to the desired full travel value.

Release completely the air signal pressure.

Tighten (loosen) slightly the spring set nut to increase (decrease) the actual signal pressure full travel value.

Release the air control pressure and recheck that the valve just commences to move toward the seat at the right spring range minimum pressure and is fully closed at the spring range maximum pressure.

After the test check the position of the travel indicator against the "arrow" of the connector and adjust its position accordingly.

Table 2: PN7000/PN8000 spring details

Actuator type	Spring Range	Travel	Number of springs	Ins. Dia. (mm)	Length (mm)	Identification (Vertical stripe)
PN7220 / PN8220	0.2 to 1 bar	20 mm	1	41.0	102	Black
PN7225 / PN8225	0.4 to 2 bar	20 mm	1	41.0	102	Yellow
PN7320 / PN8320	0.2 to 1 bar	20 mm	1	44.5	165	Black
PN7325 / PN8325	0.4 to 2 bar	20 mm	1	44.5	165	Yellow
PN7420 / PN8420	0.2 to 1 bar	20 mm	1	44.5	210	Black
PN7425 / PN8425	0.4 to 2 bar	20 mm	1	44.5	210	Yellow
PN7430 / PN8430	0.2 to 1 bar	30 mm	1	44.5	210	Black
PN7435 / PN8435	0.4 to 2 bar	30 mm	1	44.5	210	Yellow
PN7520 / PN8520	0.2 to 1 bar	20 mm	1	57.5	285	Black
PN7525 / PN8525	0.4 to 2 bar	20 mm	1	57.5	285	Yellow
PN7530 / PN8530	0.2 to 1 bar	30 mm	1	57.5	285	Black
PN7535 / PN8535	0.4 to 2 bar	30 mm	1	57.5	285	Yellow
PN7620 / PN8620	0.2 to 1 bar	20 mm	1	57.5	285	Black
PN7625 / PN8625	0.4 to 2 bar	20 mm	1	57.5	285	Yellow
PN7630 / PN8630	0.2 to 1 bar	30 mm	1	57.5	285	Black
PN7635 / PN8635	0.4 to 2 bar	30 mm	1	57.5	285	Yellow
PN7650 / PN8650	0.2 to 1 bar	50 mm	1	57.5	285	Black
PN7655 / PN8655	0.4 to 2 bar	50 mm	1	57.5	285	Yellow

5. Spare parts

The spare parts available are indicated by capital letters. The other parts are not supplied as spares.

Available spares

Stem seal kit (not for PN8000)	A
Diaphragm kit (diaphragm, 'O' ring)	A, B
Travel indicator kit	C
Spring kit	D
Linkage kit (Lock-nut, top adaptor, bottom adaptor, connectors, bolts and nuts)	E, F, G, H, I

How to order

Always order spares by using the description in the column headed 'Available spare' and stating the actuator type.

Example: 1 - Stem seal kit for PN7220 pneumatic actuator.

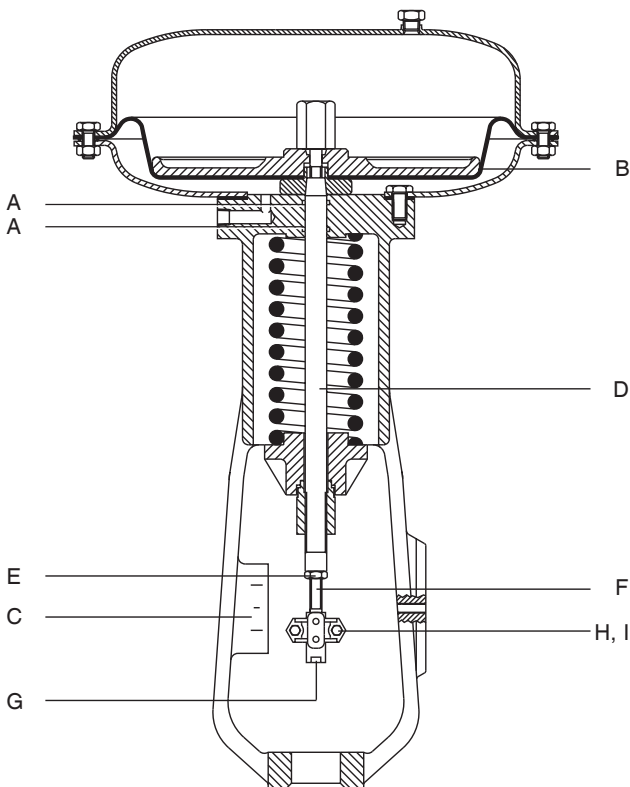

Table 2 Recommended tightening torques

Actuator series	Housing bolts (16)		Lock-nut (6)	
	Size	Torque N m	Size	Torque N m
PN7200/PN8200	M6	5 +/- 0.5	M12	40 +/- 3
PN7300/PN8300 to PN7600/PN8600	M10	15 +/- 2	M12	40 +/- 3

6. Maintenance

The PN7000 and PN8000 series pneumatic actuators are maintenance free. To ensure satisfactory operation it is strongly recommended that the control signal air is filtered and supplied free of oil and water.

Should it be necessary to replace spare parts the following procedure should be used.

6.1 Removing actuator from valve

Drive actuator into approximately mid-travel position with the air supply. Loosen and remove connectors nuts and screws (21) and remove connectors (20).

Loosen and remove yoke mounting nut and lift actuator off the valve.

Reduce air supply pressure until housing is pressure free. Disconnect air supply from the actuator.

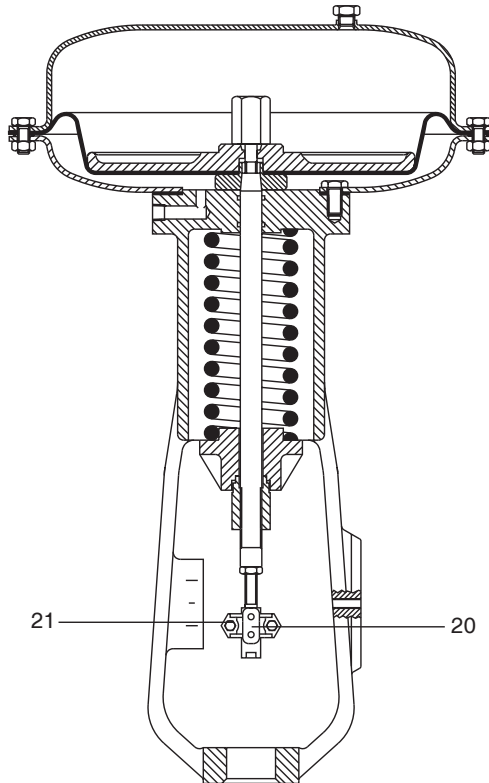

6.2 PN7000 series

6.2.1 Stem seal kit - How to fit

Remove actuator from valve as described in Section 6.1.

Loosen and remove housing screws (16) and remove housing lid (1).

Loosen top adaptor lock-nut (18) and remove top adaptor (17).

Loosen completely spring setting nut (8) and remove spring holder (9) and spring (4).

Pulling diaphragm/plate/spindle assembly withdraw actuator spindle.

Remove 'O' rings (7) taking care not to damage the grooves.

Smear new 'O' rings with silicon grease and replace.

Refit actuator spindle taking care not to damage 'O' rings or spindle surface.

Reassemble components in reverse order. Refit top housing and securing nuts and bolts (16).

Refit actuator as described in Section 3 and recommission as described in Section 4.

6.2.2 Diaphragm kit - How to fit

Loosen spring setting nut until the spring is completely unloaded.

Loosen and remove housing screws (16) and remove housing lid (1).

Using two spanners whilst holding actuator spindle (5), loosen plate lock-nut (6).

Remove diaphragm plate (3) and diaphragm (2).

Refit new diaphragm taking care that the outer holes are aligned with the corresponding holes of the bottom housing. Refit the diaphragm plate and the plate lock-nut. Using two spanners, whilst holding actuator spindle tighten plate lock-nut. Refer to Table 1 for torque ratings.

Refit top housing and securing nuts and bolts (16).

Note: To avoid distortion of the diaphragm do not fully tighten housing bolts until all bolts have been fitted. Final tightening should then be carried out evenly. Refer to Table 1 for torque ratings.

6.2.3 Spring kit - How to fit

Remove actuator from valve as described in Section 6.1.

Loosen top adaptor lock-nut (18) and remove top adaptor (17).

Loosen completely spring setting nut (8) and remove spring holder (9) and spring (4).

Replace new spring. Reassemble components in reverse order.

Refit actuator as described in Section 3 and recommission as described in Section 4.

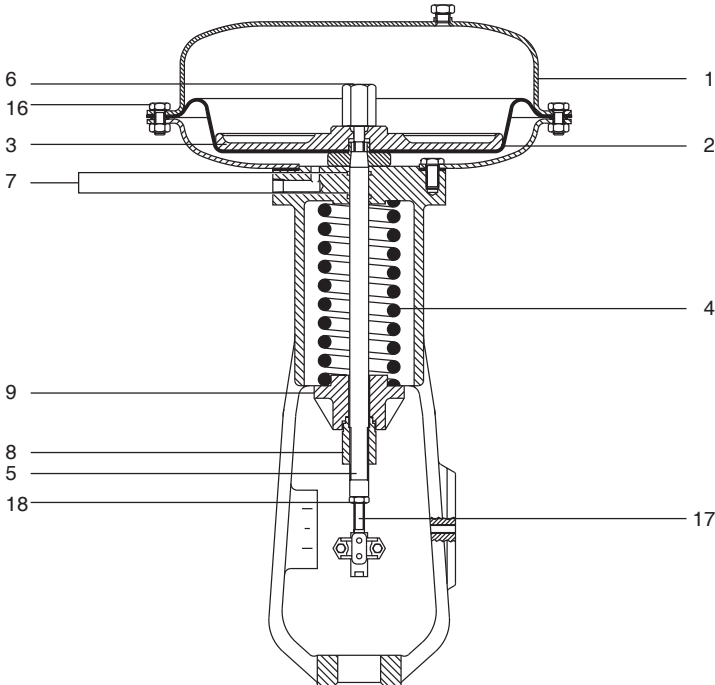

6.3 PN8000 Series

6.3.1 Diaphragm Kit - How to fit

Remove actuator from valve as described in Section 6.1.

Loosen top adaptor lock-nut (18) and remove top adaptor (17).

Loosen completely spring setting nut (8).

Loosen and remove housing screws (16) and remove housing lid (1).

Remove diaphragm (2).

Replace new diaphragm.

Refit top housing and securing nuts and bolts.

6.3.2 Spring kit - How to fit

Remove actuator from valve as described in Section 6.1.

Loosen and remove housing screws (16) and remove housing lid (1).

Remove diaphragm (2). Using two spanners whilst holding actuator spindle (5), loosen plate lock-nut (6).

Remove diaphragm plate (3) and spring (4). Replace new spring.

Refit all other items in reverse order. Using two spanners, whilst holding actuator spindle tighten plate lock-nut. Refer to Table 1 for torque ratings.

Refit top housing and securing nuts and bolts.

Note: To avoid distortion of the diaphragm do not fully tighten housing bolts until all bolts have been fitted. Final tightening should then be carried out evenly. Refer to Table 1 for torque rating.

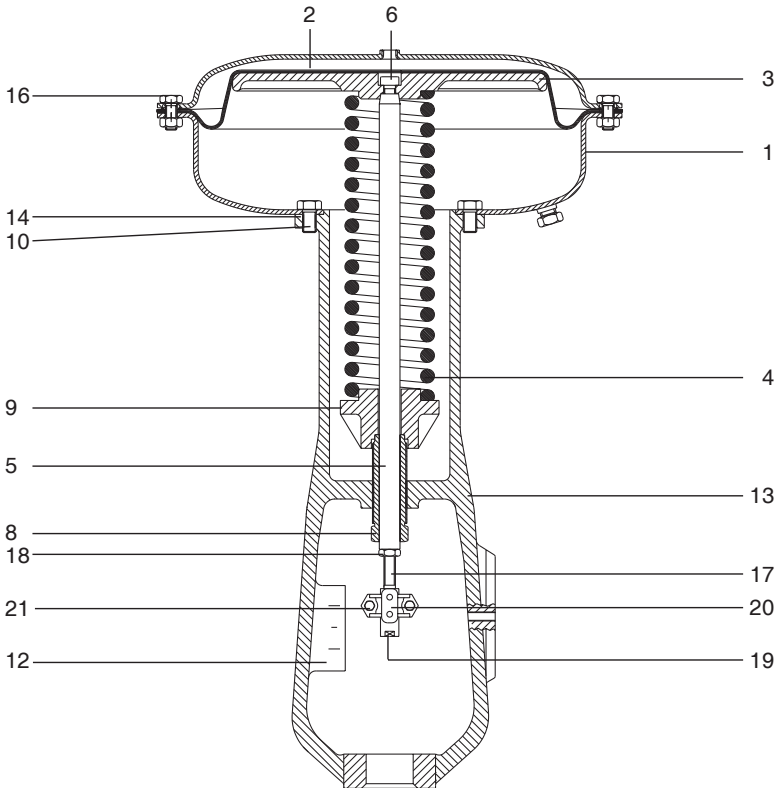



REPAIRS

Please contact our nearest Branch Office or Agent, or directly Spirax-Sarco S.r.l.
Via per Cinisello, 18 - 20834 Nova Milanese (MB) - Tel.: 0362 49 17.1 - Fax: 0362 49 17 307

LOSS OF GUARANTEE

Total or partial disregard of above instructions involves loss of any rights to guarantee.

Spirax-Sarco s.r.l. - Via per Cinisello, 18 - 20834 Nova Milanese (MB) - Telefono: +39 0362 49 17.1 - Fax +39 0362 49 17 307/8