

Electric Transducers Current to pressure ITV1030

Installation and Maintenance Instructions

SVC Manufactured for **spirax/sarco**

Attention: additional instructions are required when a ATEX intrinsically safety instrument ITV1030 is used in an explosion risk area

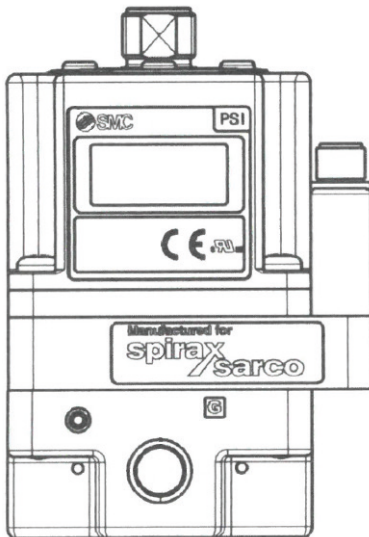

1. General Safety Information
2. General Product Information
3. Installation
4. Wiring
5. How to Order
6. Outline Dimensions (mm)
7. Maintenance and Inspection
8. Limitations of Use

1. General Safety Information

Safe operation of these products can only be guaranteed if they are properly installed, commissioned, used and maintained by qualified personnel (see paragraph 11 on this section) in compliance with the operating instructions. General installation and safety instructions for pipeline and plant construction, as well as the proper use of tools and safety equipment must also be complied with.

For use in potential explosive atmosphere, the maximum process fluid temperature must be suitable for environment where this potential explosive atmosphere is present. For the device maintenance in potential explosive atmosphere, we recommend the usage of tools which do not produce and/or propagate sparks.

1. Intended use

Referring to the Installation and Maintenance Instructions, name-plate and Technical Information Sheet, check that the product is suitable for the intended use / application. The products comply with the requirements of the European Directive 2014/34/EU (ATEX).

2. Access

Ensure safe access and if necessary a safe working platform (suitably guarded) before attempting to work on the product. Arrange suitable lifting gear if required.

3. Lighting

Ensure adequate lighting, particularly where detailed or intricate work is required.

4. Hazardous liquids or gases in the pipeline

Consider what is in the pipeline or what may have been in the pipeline at some previous time. Consider: flammable materials, substances hazardous to health, extremes of temperature.

5. Hazardous environment around the product

Consider: explosion risk areas, lack of oxygen (e.g. tanks, pits), dangerous gases, extremes of temperature, hot surfaces, fire hazard (e.g. during welding), excessive noise, moving machinery.

6. The system

Consider the effect on the complete system of the work proposed. Will any proposed action (e.g. closing isolation valves, electrical isolation) put any other part of the system or any personnel at risk? Dangers might include isolation of vents or protective devices or the rendering ineffective of controls or alarms. Ensure isolation valves are turned on and off in a gradual way to avoid system shocks.

7. Pressure systems

Ensure that any pressure is isolated and safely vented to atmospheric pressure. Consider double isolation (double block and bleed) and the locking or labelling of closed valves. Do not assume that the system has depressurised even when the pressure gauge indicates zero.

8. Temperature

Allow time for temperature to normalise after isolation to avoid danger of burns

9. Tools and consumables

Before starting work ensure that you have suitable tools and /or consumables available. Use only genuine Spirax Sarco replacement parts.

10. Protective clothing

Consider whether you and / or others in the vicinity require any protective clothing to protect against the hazards of, for example, chemicals, high / low temperature, radiation, noise, falling objects, and dangers to eyes and face.

11. Permits to work

All work must be carried out or be supervised by a suitably competent person. Installation and operating personnel should be trained in the correct use of the product according to the Installation and Maintenance Instructions.

Where a formal 'permit to work' system is in force it must be complied with. Where there is no such system, it is recommended that a responsible person should know what work is going on and, where necessary, arrange to have an assistant whose primary responsibility is safety.

Post 'warning notices' if necessary.

12. Handling

Manual handling of large and / or heavy products may present a risk of injury. Lifting, pushing, pulling, carrying or supporting a load by bodily force can cause injury particularly to the back. You are advised to assess the risks taking into account the task, the individual, the load and the working environment and use the appropriate handling method depending on the circumstances of the work being done.

13. Residual hazards

In normal use the external surface of the product may be very hot. If used at the maximum permitted operating conditions the surface temperature of some products may reach temperatures of 176°F. Many products are not self-draining. Take due care when dismantling or removing the product from an installation (refer to 'Maintenance instructions').

14. Freezing

Provision must be made to protect products which are not self-draining against frost damage in environments where they may be exposed to temperatures below freezing point.

15. Disposal

Unless otherwise stated in the Installation and Maintenance Instructions, this product is recyclable and no ecological hazard is anticipated with its disposal providing due care is taken.

16. Returning products

Customers and stockists are reminded that under EC Health, Safety and Environment Law, when returning products to Spirax Sarco they must provide information on any hazards and the precautions to be taken due to contamination residues or mechanical damage which may present a health, safety or environmental risk.

This information must be provided in writing including Health and Safety data sheets relating to any substances identified as hazardous or potentially hazardous.

2. General product information

2.1 Specifications

Model		ITV1030-01F1BN4-DIU00490
Min. supply pressure		Set pressure + 15 psi
Max. supply pressure		145 psi
Set pressure range		da 0.7 to 70 psi
Supply voltage		DC24 V±10%
Current consumption		DC2A or less
Input signal	Current type	DC4 to 20 mA
Input impedance	Current type	250Ω or less ^{note 5}

Output signal ^{note2}	Analogue	1 to 5 VDC (Output impedance: Approx.1kΩ) Output accuracy ±6%F.S. or less
Linearity		±1% F.S. or less
Hysteresis		0.5% F.S. or less
Repeatability		±0.5% F.S. or less
Sensitivity		0.2% F.S. or less
Temperature characteristics		±0.12% F.S./°C or less
Operating temperature		0 to 50°C (No condensation)
Pressure display	Accuracy	±2% F.S ±1 digit or less
	Min. Unit	psi: 0.1
Protection structure		Unlike standard specification. It is not dustproof or waterproof
Weight		Approx. 300g (No accessories)

Note 1: 0.7 psi or less residual pressure might be existed even though 0% input signal should be 0 psi output pressure before shipment. It is recommended to add 3-ports valve to exhaust at the outlet when 0psi outlet pressure requested completely.

Note 2: The setting (Zero/Span, Preset input, Switch output) can be adjusted by each minimum display unit. The unit cannot be changed.

Note 3: This product is the special that output pressure is exhausted and become 0.7 psi or less when power supply is turned off.

Note 4: Controlling so that output pressure is 0.7 psi or less when input signal is approx. 3.8 mA or less. With this condition, if input signal is approx. 4 mA or more, it will convert to normal control mode. Therefore, output pressure chattering may occur when input signal is between 3.8 to 4 mA.

Note 5: Value for the state with no over current included. If an allowance is provided for an over current circuit, the input impedance varies depending on the input current. This is 350Ω or less for an input current of 20 mA DC.

Nota 6: Collegare l'elettrovalvola esterna alla stessa fonte di alimentazione del regolatore E/P.

Nota 7: La pressione di alimentazione massima del prodotto diventa 100 psi secondo la specifica della valvola V111-5WOU.

Nota 8: Il cavo del connettore M8 non è incluso. Ordinare il cavo del connettore V100-49-1-5 (3 m) separatamente.

2.2 Principio di funzionamento

When the input signal increases the supply solenoid valve ① turns on and the exhaust solenoid valve ② turns off. Supply pressure is passed to the pilot valve ③ through the supply solenoid valve. The pilot valve will open.

The main valve allowing partial supply pressure to pass to the out port. The pressure sensor ④ will provide output pressure feedback to the control circuit ⑤. The control circuit will balance the input signal and output pressure to ensure that the output pressure remains proportional to the input signal.

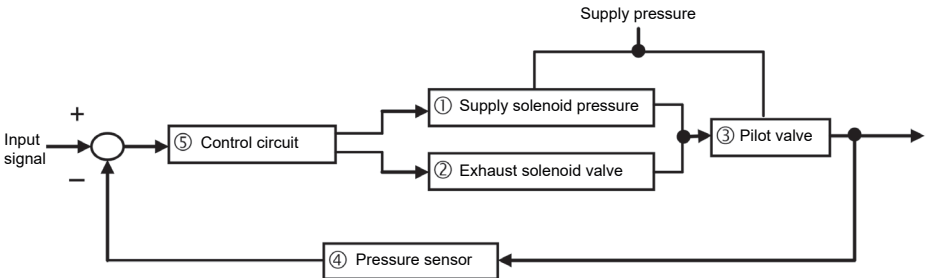

Fig. 1 - Control diagram

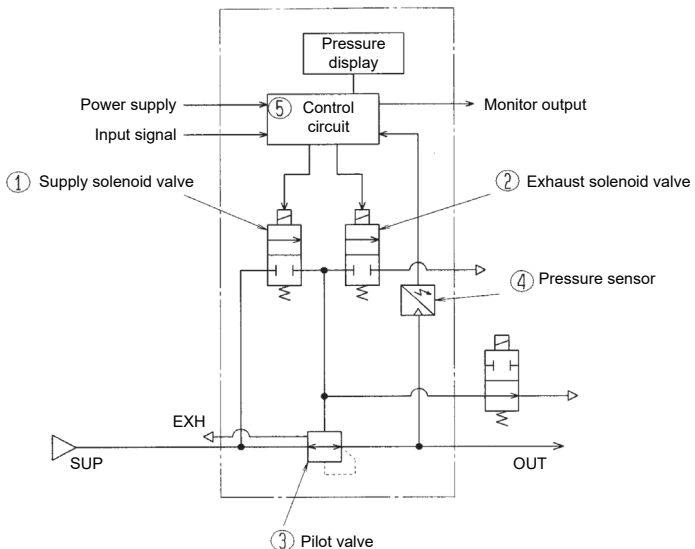

Fig. 2 - Schematic diagram

3. Installation

3.1 Installation



Warning

- Do not install the product unless the safety instructions have been read and understood.
- This product is pre-set at the factory and must not be dismantled by the user. Contact your local SMC office for advice.
- Ensure, when installing this product, that it is kept clear of power lines to avoid noise interference.
- Ensure that load surge protection is fitted when inductive loads are present (i.e. solenoid, relay etc.).
- Ensure precautions are in place if the product is used in a 'free flow output' condition. Air will continue to flow continuously.
- Do not use a lubricator on the input side of this product. If lubrication is necessary, place the lubricator on the 'output' side.
- Ensure all air is exhausted from the product before maintenance.
- The length of the connector cable should be 10 m maximum.

3.2 Environment



Warning

- Do not use in an environment where corrosive gases, chemicals, salt water or steam are present.
- Do not use in an explosive atmosphere.
- Do not expose to direct sunlight. Use a suitable protective cover.
- Do not install in a location subject to vibration or impact. Check the product specifications.
- Do not mount in a location exposed to radiant heat.

3.3 Piping



Warning

- Before piping make sure to clean up chips, cutting oil, dust etc.
- When installing piping or fittings, ensure sealant material does not enter inside the port. When using seal tape, leave 1.5 to 2 threads exposed on the end of the pipe/fitting.
- Tighten fittings to the specified tightening torque.

Thread	Tightening Torque (Nm)
1/8	3 to 5

3.4 Lubrification

Caution

- Do not use a lubricator on the supply side of this product, as this can cause malfunction. When lubrication of terminal equipment is necessary, connect a lubricator on the output side of this equipment.

4. Cablaggio

Caution

- Proceed carefully, as incorrect wiring can cause damage.
- Use a DC power supply with sufficient capacity and a low ripple.
- Turn off the power supply to remove and insert the connector.
- Never rotate the right angled type connector as it is not designed to rotate.

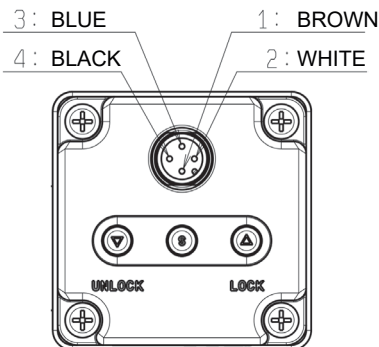

1	Brown	Power supply
2	White	Input signal
3	Blue	GND (Common)
4	Black	Monitor output

(Note) The wire colour is show for when the optional cable is used

Wiring diagram

Current / Voltage type

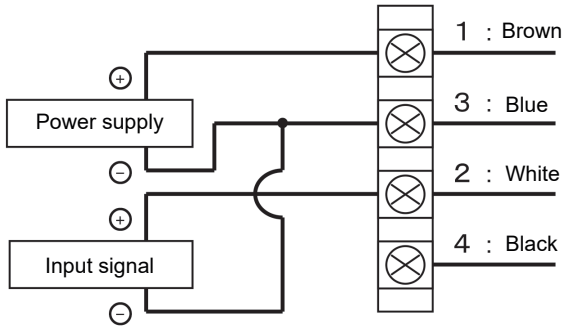

Power supply 24 VDC

Input signal 4~20 mADC

Monitor output wiring diagram
Analogue output - Voltage type

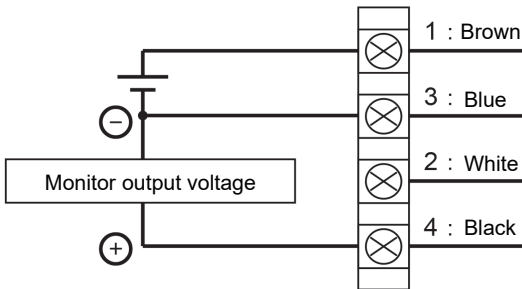

Only use equipment with minimum load impedance of 100 kΩ.

5. How to Order

How to order

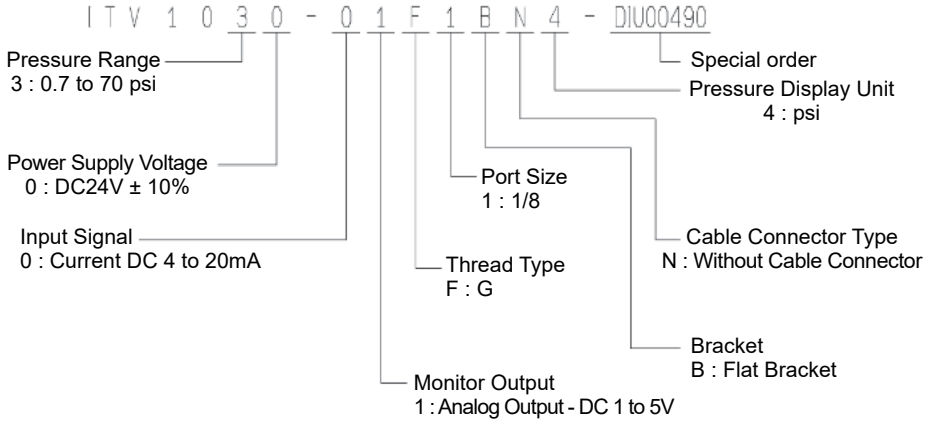

6. Outline Dimensions (mm)

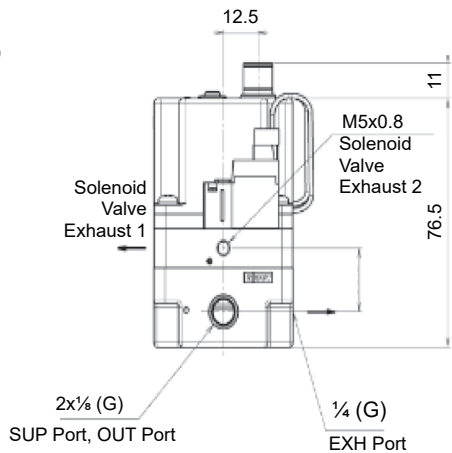
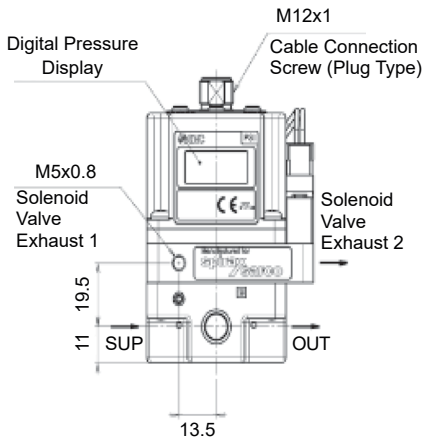
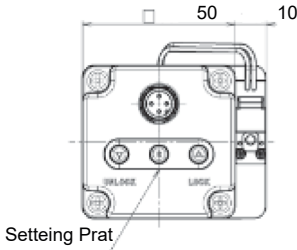

7. Maintenance and inspection

Caution

- Not following proper maintenance procedures could cause the product to malfunction and lead to equipment damage.
- If handled improperly, compressed air can be dangerous. Maintenance of pneumatic systems should be performed only by qualified personnel.
- Before performing maintenance, turn off the power supply and be sure to cut off the supply pressure. Confirm that the air is released to atmosphere.
- After installation and maintenance, apply operating pressure and power to the equipment and perform appropriate functional and leakage tests to make sure the equipment is installed correctly.
- Do not make any modification to the product.
- Do not disassemble the product, unless required by installation or maintenance instructions.

8. Limitazioni d'impiego

Caution

- If the electric power supply is shut off while pressure is being applied, the pressure will be maintained on the output side. However, this output pressure is held only temporarily and is not guaranteed. If exhausting of this pressure is desired, shut off the power after reducing the set pressure, and discharge the air using a residual pressure exhaust valve, etc.
- If power to this product is cut off due to a power failure, etc. when it is in a controlled state, output pressure will be retained temporarily. Handle carefully when operating with output pressure released to the atmosphere, as air will continue to flow out.
- If supply pressure to this product is interrupted while the power is still on, the internal solenoid valve will continue to operate and a humming noise may be generated. Disconnect the power supply when the supply pressure is shut off, as the life of the product may be shortened.
- Do not block three exhaust ports on this product.
- This product does not have a shut-off valve function. If air pressure is supplied without electric power being applied, the output pressure may increase to a pressure equivalent to the exhaust port when output pressure is generated. Operate the system to shut off the supply pressure when not operating the product.
- The product is adjusted for each specification at the time of shipment from the factory. Do not perform unnecessary disassembly or removal of parts as it will cause failure.

SERVICE

For technical support, please contact our local Sales Engineer or our Head Office directly:

Spirax Sarco S.r.l. - Technical Assistance

Via per Cinisello, 18 - 20834 Nova Milanese (MB) - Italy

Tel.: (+39) 0362 4917 257 - (+39) 0362 4917 211 - Fax: (+39) 0362 4917 315

E-mail: support@it.spiraxsarco.com

LOSS OF GUARANTEE

Total or partial disregard of above instructions involves loss of any rights to guarantee.

Spirax-Sarco S.r.l. - Via per Cinisello, 18 - 20834 Nova Milanese (MB) - Tel.: 0362 49 17.1 - Fax: 0362 49 17 307