

AEL3
Power modules
Installation Instructions

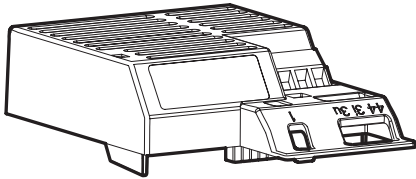

1. 100-110 V and 230 V power module installation
2. Removing the power module

1. 100-110 V and 230 V power module installation



Note:
Not compatible with Split-Range unit

There are 2 additional options available for power supply: 100-110 V and 230 V. These are available by connecting an auxiliary power module to the standard actuator model. Fresh labels are provided that reflect the change made.

1. Open the actuator cover.
2. Slot in the appropriate power module in the space provided.
3. Replace/cover the original 24V wiring label on the inside of the actuator removable housing cover with fresh power module wiring label.
4. Use provided power module marking label and affix it on the existing label located on the underside of the actuator housing, so that it covers the existing portion of the label containing 24V and UL markings, as shown below.

Guidelines for the electrician

Fig. 1

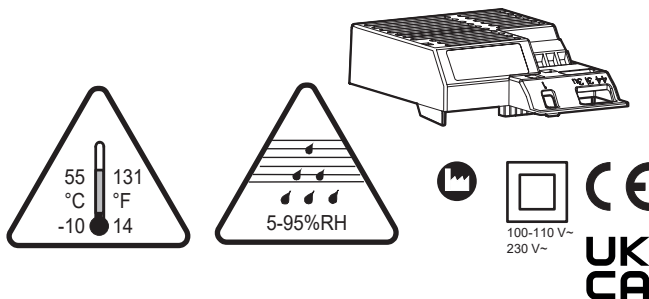
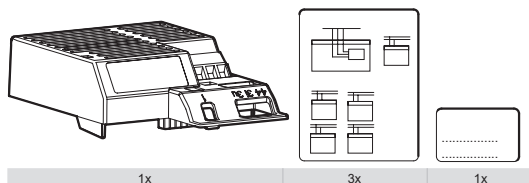

Fig. 2



AEL3 Power modules

spirax
sarco

	T15
	3
	1

Fig. 3

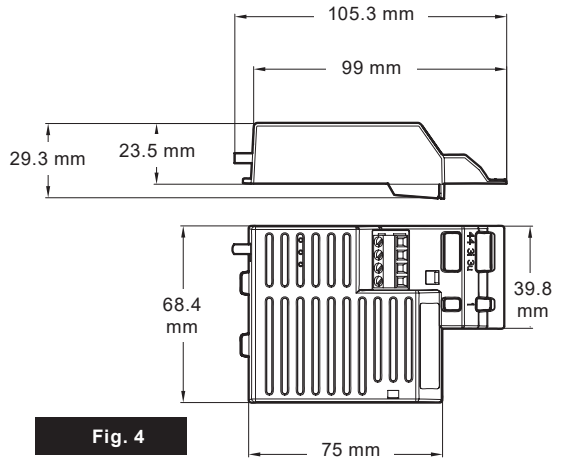

Fig. 4

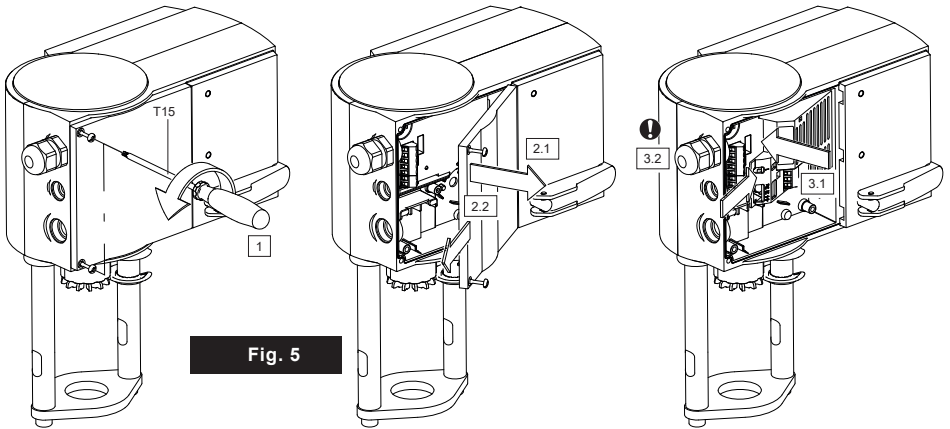

Fig. 5

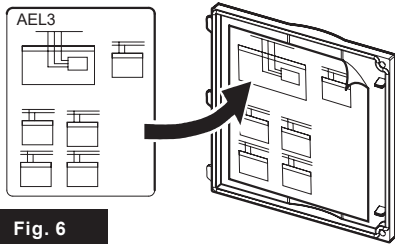
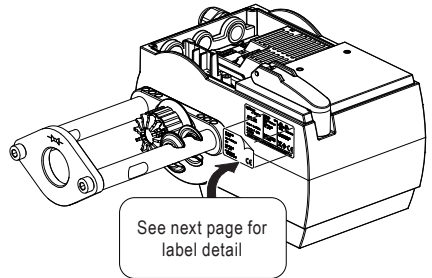

Fig. 6



Danger of electrocution

- Do not make a connection between terminal blocks X and Y.

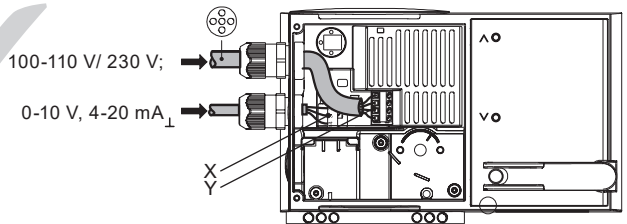
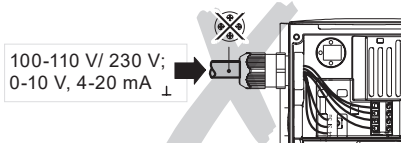













Fig. 7

spirax/sarco AEL3E Date Code: XXX-A Country of Origin: Germany	24 Vac/dc 12W 50/60Hz max. -10T55 (60)°C IP66 Control Signal: DC 0...10V	 28BA E76224 23FR AVF2348F232U Temperature Indicating & Regulating Equipment  
	Equipment Intended for connection to a Class 2 power source.	  

Spirax-Sarco Limited, Charlton House, Cheltenham, Gloucestershire, GL53 8ER, GB

spirax/sarco AEL3E Date Code: XXX-A Country of Origin: Germany	230 V~ 28 VA 50/60Hz max. -10T55 (60)°C IP66 Control Signal: DC 0...10V Pollution Deg. 3 Overvoltage Cat. III	    
	Equipment Intended for connection to a Class 2 power source.	

Spirax-Sarco Limited, Charlton House, Cheltenham, Gloucestershire, GL53 8ER, GB

















230 V~ 28 VA 50/60Hz max. -10T55 (60)°C IP66 Control Signal: DC 0...10V Pollution Deg. 3 Overvoltage Cat. III	    
--	---

Fig. 8a

spirax/sarco AEL3E Date Code: XXX-A Country of Origin: Germany	24 Vac/dc 12W 50/60Hz max. -10T55 (60)°C IP66 Control Signal: DC 0...10V	 28BA E76224 23FR AVF2348F232U Temperature Indicating & Regulating Equipment  
	Equipment Intended for connection to a Class 2 power source.	  

Spirax-Sarco Limited, Charlton House, Cheltenham, Gloucestershire, GL53 8ER, GB

spirax/sarco AEL3E Date Code: XXX-A Country of Origin: Germany	100-110V~ 28 VA 50/60Hz max. -10T55 (60)°C IP66 Control Signal: DC 0...10V Pollution Deg. 3 Overvoltage Cat. III	    
	Equipment Intended for connection to a Class 2 power source.	

Spirax-Sarco Limited, Charlton House, Cheltenham, Gloucestershire, GL53 8ER, GB





100-110V~ 28 VA 50/60Hz max. -10T55 (60)°C IP66 Control Signal: DC 0...10V Pollution Deg. 3 Overvoltage Cat. III	    
---	---

Fig. 8b

AEL3 Power modules



1.1 Valve Motor Drive connection for actuators fitted with power module

AEL3E/AEL3R

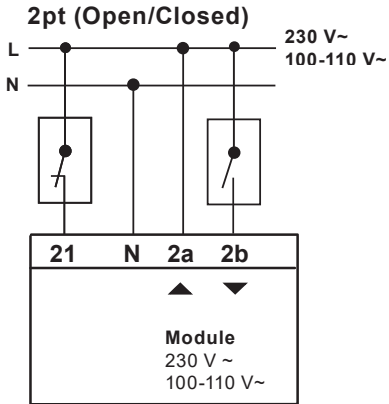
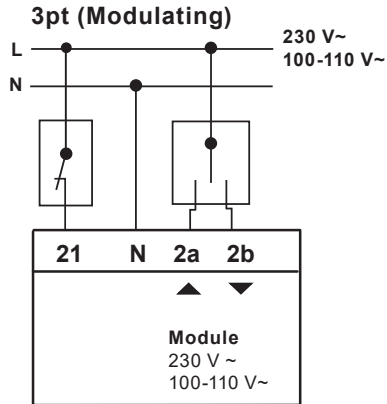

Fig. 9a

AEL3E/R



AEL3E/R

AEL3X

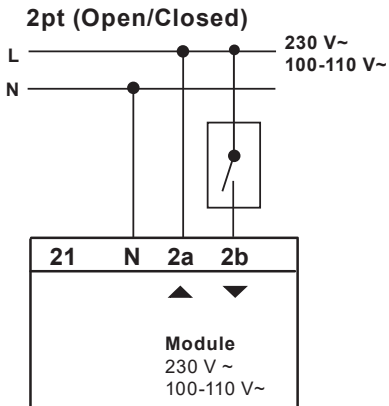
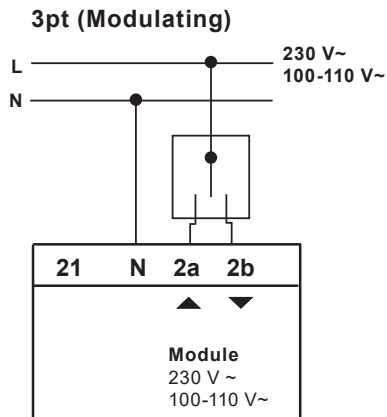

Fig. 9b

AEL3X



AEL3X

1.2 Signal connection for actuators fitted with a power module: 4-20 mA or 0-10 V

Note: Actuator action can be reversed via terminals 2a and 2b.

AEL3E/AEL3R

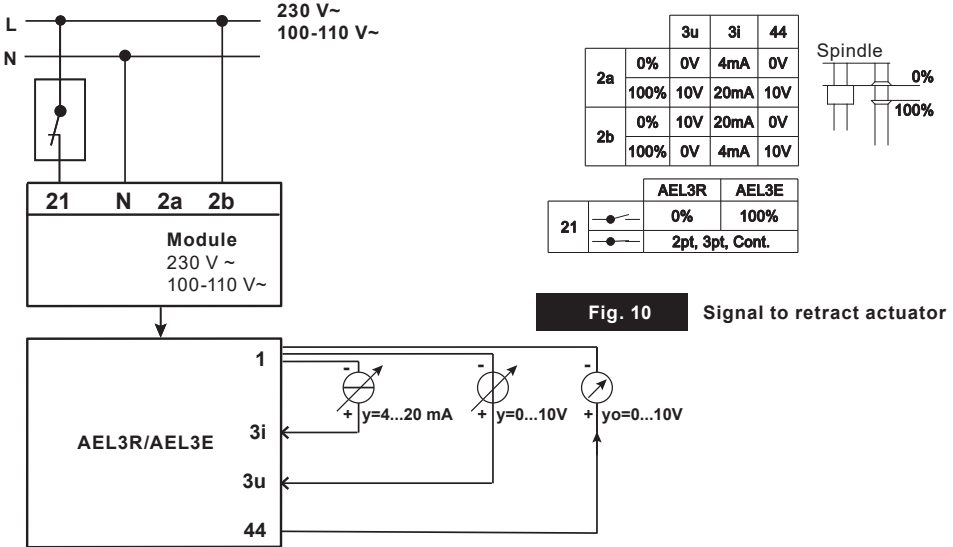

Fig. 10 Signal to retract actuator

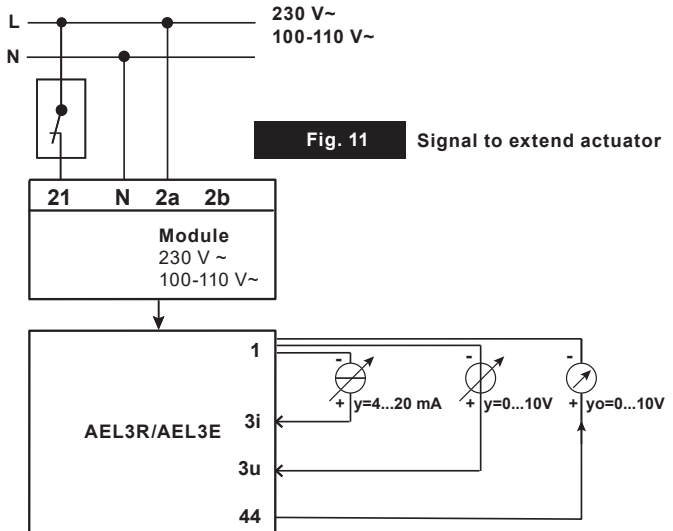

Fig. 11 Signal to extend actuator

AEL3 Power modules



AEL3X

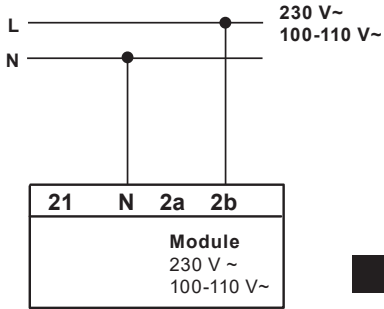

Fig. 12a Signal to retract actuator

		3u	3i	44	
2a	0%	0V	4mA	0V	Spindle 0%
	100%	10V	20mA	10V	
2b	0%	10V	20mA	0V	Spindle 0%
	100%	0V	4mA	10V	

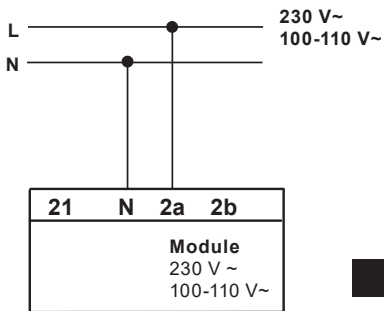
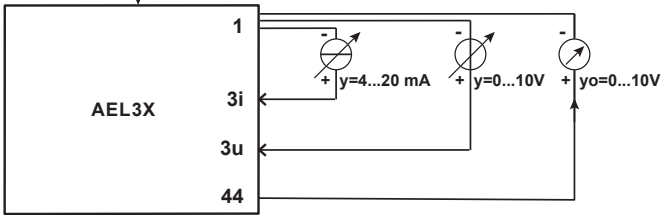
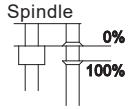
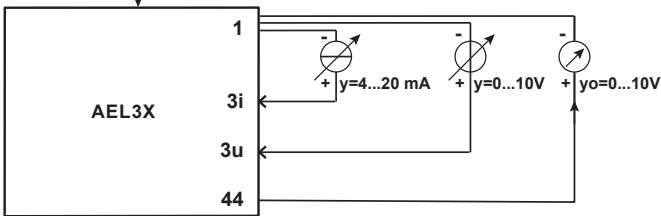

Fig. 12b Signal to extend actuator



2. Removing the power module

1. Ensure actuator is disconnected from power supply.
2. Remove all wiring from the terminals.
3. Insert a flathead screwdriver in the slot as shown in the diagram.
4. Depress the screwdriver and push it gently to the right to unlock the latch. Be careful not to break it off.
5. While applying gentle pressure on the latch, pry the power module away from the actuator.

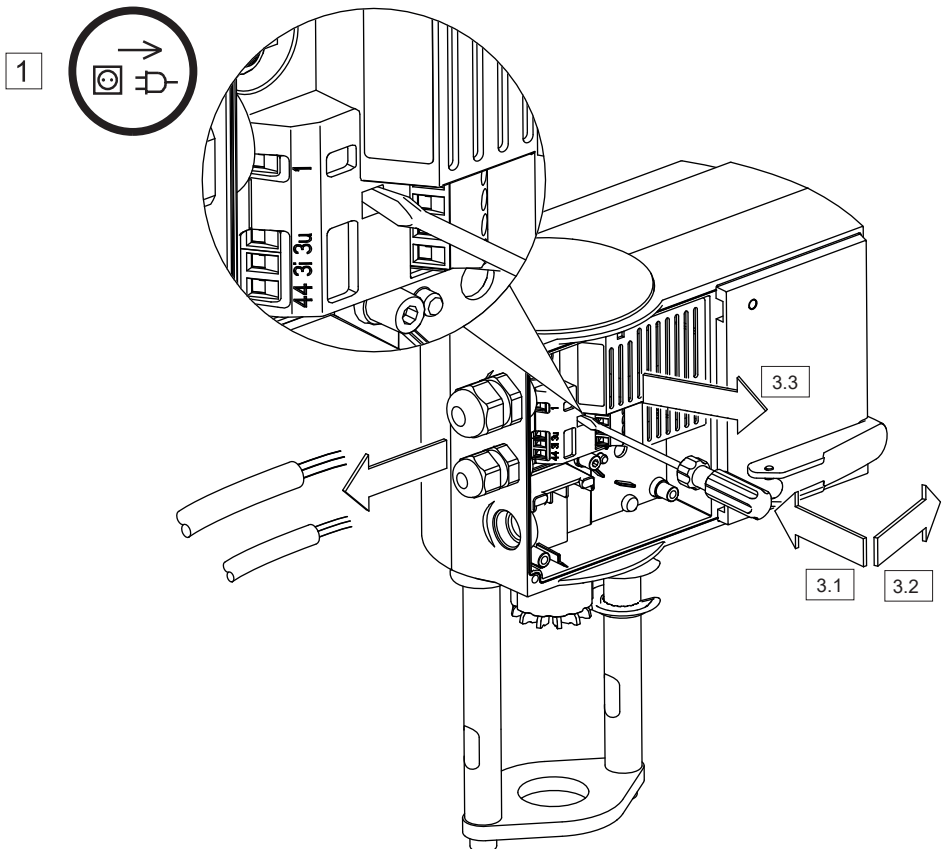

Fig. 13

