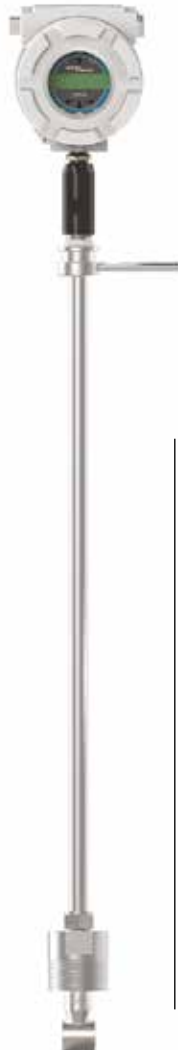

**VLM20 In-line Vortex Flowmeter and
VIM20 Vortex Insertion Flowmeter**
Installation and Maintenance Instructions

**VLM20****VIM20**

1. Safety information
2. Introduction
3. Installation
4. Operating instructions
5. Serial communications
6. Troubleshooting and repair
7. Appendixes

Customer Notice for Oxygen Service

**This flowmeter is not intended for oxygen service.
Spirax Sarco Limited is not liable for any damage or personal injury,
whatsoever, resulting from the use of Spirax Sarco Vortex Insertion and
In-line flowmeters for oxygen gas.
If oxygen service is required please consult factory.**

Customer Notice for EMC Class Division

**This flowmeter is suitable for EMC Class A environments only.
Class A equipment is suitable for use in all establishments other than
domestic and those connected to a low voltage power supply network
which supplies buildings used for domestic purposes.
There may be potential difficulties in ensuring electromagnetic
compatibility in other environments, due to conducted as well as radiated
disturbances.**

1. Safety information

1.1	Receipt of system components	6
1.2	Technical assistance	6

2. Introduction

2.1	How the vortex mass flowmeter operates	8
2.2	Velocity measurement	8
2.3	Vortex shedding frequency	9
2.4	Vortex frequency sensing	9
2.5	Flow velocity range	10
2.6	Temperature measurement	11
2.7	Pressure measurement	11
2.8	Flowmeter configurations	12
2.9	Multivariable options	12
2.10	Line size / process conditions / materials	12
2.11	Flowmeter electronics	13

3. Installation

3.1	Installation overview	14
3.2	Flowmeter installation requirements	14
3.3	Unobstructed flow requirements	14
3.4	VLM20 in-line flowmeter installation	16
3.5	Wafer-style flowmeter installation	17
3.6	Flange-style flowmeter installation	18
3.7	VIM20 Vortex insertion flowmeter installation	20
3.8	Cold tap guidelines	21
3.9	Hot tap guidelines	22
3.10	Flowmeter insertion	24
3.11	Installing flowmeters with a compression connection*	25
3.12	Installing flowmeters with a packing gland connection*	27
3.13	Installation of meters with packing gland connection (No Insertion Tool)*	32
3.14	Adjusting meter orientation	34
3.15	Display / keypad adjustment (All meters)	34
3.16	Enclosure adjustment (VLM20 only)	35
3.17	Loop power flowmeter wiring connections	36
3.18	Input power connections	36
3.19	4-20 mA output connections	37
3.20	Pulse output connections	38
3.21	Frequency output connections	39
3.22	Optional backlight connections	39
3.23	Remote electronics wiring	40
3.24	High power flowmeter wiring connections	41
3.25	Input power connections	42
3.26	4-20 mA output connections	44
3.27	Frequency output connections	46
3.28	Pulse output connections	48
3.29	Alarm output connections	50
3.30	Remote electronics wiring	52
3.31	Optional input electronics wiring	52
3.32	Optional energy EM RTD input wiring	53
3.33	Optional external 4-20 mA input wiring	53
3.34	Optional contact closure input wiring	54

4. Operating instructions

4.1	Flowmeter display/keypad	55
4.2	Start-up	56
4.3	Using the setup menus	58
4.4	Programming the flowmeter	59
4.5	Output menu	60
4.6	Display menu	62
4.7	Alarms menu	64
4.8	Totalizer #1 menu	66
4.9	Totalizer #2 menu	68
4.10	Energy menu	69
4.11	Fluid menu	70
4.12	Units menu	72
4.13	Time and date menu	73
4.14	Diagnostics menu	74
4.15	Calibration menu	76
4.16	Password menu	77

5. Serial communications

5.1	HART communications	78
5.2	Wiring	78
5.3	HART commands with the DD menu	80
5.4	HART commands with generic DD menu	86
5.5	MODBUS communications	90
5.6	Register definitions	93
5.7	BACNET MS/TP communications	99
5.8	Baud rates on the MS/TP Bus	99
5.9	Supported BACnet objects	100
5.10	ANNEX - BACnet protocol implementation conformance statement	106
5.11	Acronyms and definitions	110

6. Troubleshooting and repair

6.1	Hidden diagnostics menus	110
6.2	Level one hidden diagnostics values	112
6.3	Level two hidden diagnostics values	114
6.4	Analogue output calibration	116
6.5	Troubleshooting the flowmeter	116
6.6	First check items	116
6.7	Record values	116
6.8	Determine the fault	118
6.9	Electronics assembly replacement (all meters)	122
6.10	Pressure sensor replacement (VLM20 only)	122
6.11	Returning equipment to the factory	122

7. Appendixes

7.1	Appendix A Product specifications	123
7.2	Appendix B Approvals	132
7.3	Appendix C Flowmeter calculations	133
7.4	Appendix D glossary	137

1. Safety information

Supplier:

Spirax-Sarco Limited
Charlton House
Charlton Kings
Cheltenham
Glos
GL53 8ER

We use Warning, Caution and Note statements throughout this book to draw your attention to important information.



Warning!

This statement appears with information that is important to protect people and equipment from damage. Pay very close attention to all warnings that apply to your application.



Caution!

This statement appears with information that is important for protecting your equipment and performance. Read and follow all cautions that apply to your application.



Note

This statement appears with a short message to alert you to an important detail.

1.1 Receipt of system components

When receiving a Spirax Sarco mass flowmeter, carefully check the outside packing carton for damage incurred in shipment. If the carton is damaged, notify the local carrier and submit a report to the factory or distributor.

Remove the packing slip and check that all ordered components are present. Make sure any spare parts or accessories are not discarded with the packing material. Do not return any equipment to the factory without first contacting Spirax Sarco Customer Service.

1.2 Technical assistance

If you encounter a problem with your flowmeter, review the configuration information for each step of the installation, operation and set up procedures.

Verify that your settings and adjustments are consistent with factory recommendations. Refer to Section 6, Troubleshooting, for specific information and recommendations.

If the problem persists after following the troubleshooting procedures outlined in Section 6. Contact Spirax Sarco Customer Support between 8:00am and 5:00pm.

When calling Technical Support, have the following information on hand:

- the serial number and Spirax Sarco order number (all marked on the meter nameplate)
- the problem you are encountering and any corrective action taken
- application information (fluid, pressure, temperature and piping configuration)



Warning!

Consult the flowmeter nameplate for specific flowmeter approvals before any hazardous location installation.

Hot tapping must be performed by a trained professional, regulations often require a hot tap permit. The manufacturer of the hot tap equipment and/or the contractor performing the hot tap is responsible for providing proof of such a permit.

All flowmeter connections, isolation valves and fittings for cold/hot tapping must have the same or higher pressure rating as the main pipeline.

For VIM20 Vortex Insertion Flowmeter installations, an insertion tool must be used for any installation where a flowmeter is inserted under pressure greater than 3.45 bar g (50 psi g).

To avoid serious injury, DO NOT loosen a compression fitting under pressure.

To avoid potential electric shock, follow National Electric Code or your local code when wiring this unit to a power source. Failure to do so could result in injury or death. All ac power connections must be in accordance with published CE directives. All wiring procedures must be performed with the power Off.

Before attempting any flowmeter repair, verify that the line is not pressurized. Always remove main power before disassembling any part of the mass flowmeter.



Caution!

Calibration must be performed by qualified personnel. Spirax Sarco strongly recommends that you return your flowmeter to the factory for calibration.

In order to achieve accurate and repeatable performance, the flowmeter must be installed with the specified minimum length of straight pipe upstream and downstream of the flowmeter's sensor head.

When using toxic or corrosive gases, purge the line with inert gas for a minimum of four hours at full gas flow before installing the flowmeter.

For VIM20 Vortex Insertion Flowmeter installations, the sensor alignment pointer must point downstream in the direction of flow.

The ac wire insulation temperature rating must meet or exceed 85 °C (185 °F).

2. Introduction

2.1 How the vortex mass flowmeter operates

VLM20 In-line Vortex mass flowmeter and VIM20 Vortex insertion flowmeter use a unique sensor head to monitor mass flow rate by directly measuring three variables—fluid velocity, temperature and pressure. The built-in flow computer calculates the mass flow rate and volumetric flow rate based on these three direct measurements. The velocity, temperature and pressure sensing head is built into the vortex meter's flow body. To measure fluid velocity, the flowmeter incorporates a bluff body (shedder bar) in the flow stream and measures the frequency of vortices created by the shedder bar. Temperature is measured using a platinum resistance temperature detector (PRTD). Pressure measurement is achieved using a solid-state pressure transducer. All three elements are combined into an integrated sensor head assembly located downstream of the shedder bar within the flow body.

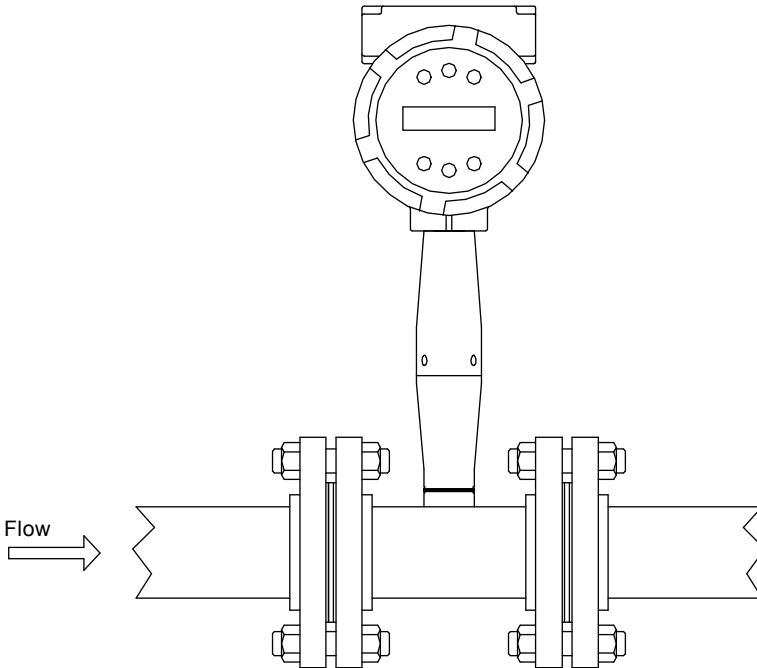

Fig. 1 In-line vortex multi-parameter mass flowmeter

2.2 Velocity measurement

The vortex velocity sensor is a patented mechanical design that minimizes the effects of pipeline vibration and pump noise, both of which are common error sources in flow measurement with vortex flowmeters. The velocity measurement is based on the well-known Von Karman vortex shedding phenomenon. Vortices are shed from a shedder bar, and the vortex velocity sensor located downstream of the shedder bar senses the passage of these vortices. This method of velocity measurement has many advantages including inherent linearity, high turndown, reliability and simplicity.

2.3 Vortex shedding frequency

Von Karman vortices form downstream of a shedder bar into two distinct wakes. The vortices of one wake rotate clockwise while those of the other wake rotate counterclockwise. Vortices generate one at a time, alternating from the left side to the right side of the shedder bar. Vortices interact with their surrounding space by over-powering every other nearby swirl on the verge of development. Close to the shedder bar, the distance (or wave length) between vortices is always constant and measurable. Therefore, the volume encompassed by each vortex remains constant, as shown below. By sensing the number of vortices passing by the velocity sensor, the flowmeter computes the total fluid volume.

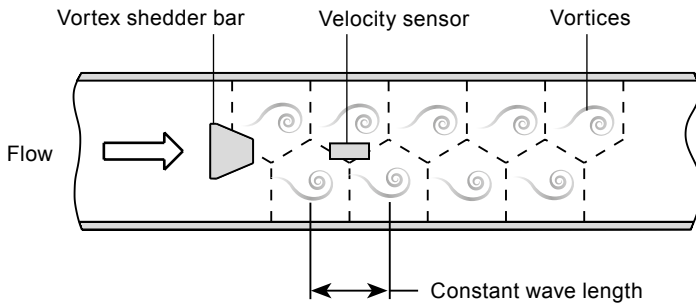

Fig. 2 Measurement principle of vortex flowmeters

2.4 Vortex frequency sensing

The velocity sensor incorporates a piezoelectric element that senses the vortex frequency. This element detects the alternating lift forces produced by the Von Karman vortices flowing downstream of the vortex shedder bar. The alternating electric charge generated by the piezoelectric element is processed by the transmitter's electronic circuit to obtain the vortex shedding frequency. The piezoelectric element is highly sensitive and operates over a wide range of flows, pressures and temperatures

2.5 Flow velocity range

To ensure trouble-free operation, vortex flowmeters must be correctly sized so that the flow velocity range through the meter lies within the measurable velocity range (with acceptable pressure drop) and the linear range.

The measurable range is defined by the minimum and maximum velocity using the following table.

	Gas	Liquid	
Vmin Vmax	$\sqrt{\frac{25 \text{ ft/s}}{\rho}}$ 300 ft/s	1 ft/s 30 ft/s	English ρ (lb/ft ³)
Vmin Vmax	$\sqrt{\frac{37 \text{ m/s}}{\rho}}$ 91 m/s	0.3 m/s 9.1 m/s	Metric ρ (kg/m ³)

The pressure drop for VIM20 insertion meters is negligible. The pressure drop for VLM20 in-line meters is defined as:

$$\Delta P = .00024 \rho V^2 \quad \text{English units } (\Delta P \text{ in psi, } \rho \text{ in lb/ft}^3, V \text{ in ft/sec})$$

$$\Delta P = .000011 \rho V^2 \quad \text{Metric units } (\Delta P \text{ in bar, } \rho \text{ in kg/m}^3, V \text{ in m/sec})$$

The linear range is defined by the Reynolds number. The Reynolds number is the ratio of the inertial forces to the viscous forces in a flowing fluid and is defined as:

$$R_e = \frac{\rho V D}{\mu}$$

Where

R_e = Reynolds Number

ρ = mass density of the fluid being measured

V = velocity of the fluid being measured

D = internal diameter of the flow channel

μ = viscosity of the fluid being measured

The Strouhal number is the other dimensionless number that quantifies the vortex phenomenon. The Strouhal number is defined as:

$$St = \frac{f d}{V}$$

Where

St = Strouhal Number

f = frequency of vortex shedding

d = shedder bar width

V = fluid velocity

As shown in Figure 3, flowmeters exhibit a constant Strouhal number across a large range of Reynolds numbers, indicating a consistent linear output over a wide range of flows and fluid types. Below this linear range, the intelligent electronics in automatically corrects for the variation in the Strouhal number with the Reynolds number. The meter's smart electronics corrects for this non-linearity via its simultaneous measurements of the process fluid temperature and pressure. This data is then used to calculate the Reynolds number in real time. Flowmeters automatically correct down to a Reynolds number of 5,000.

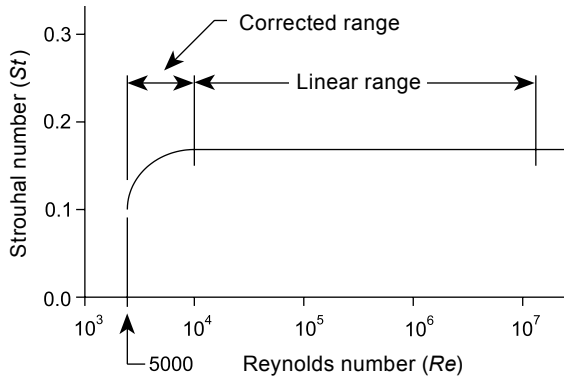

Fig. 3 Reynolds number range

2.6 Temperature measurement

Spirax Sarco's flowmeters use a 1000 ohm platinum resistance temperature detector (PRTD) to measure fluid temperature.

2.7 Pressure measurement

Spirax Sarco's flowmeters incorporate a solid-state pressure transducer isolated by a 316 stainless steel diaphragm. The transducer itself is micro-machined silicon, fabricated using integrated circuit processing technology. A nine-point pressure/temperature calibration is performed on every sensor. Digital compensation allows these transducers to operate within a 0.3% of full scale accuracy band within the entire ambient temperature range of -40 °F to 140 °F (-40 to 60 °C). Thermal isolation of the pressure transducer ensures the same accuracy across the allowable process fluid temperature range of -330 °F to 750 °F (-200 to 400 °C).

2.8 Flowmeter configuration

Vortex Mass Flowmeters are available in two model configurations:

- VLM20 Vortex In-line Flowmeter (replaces a section of the pipeline)
- VIM20 Vortex Insertion Flowmeter (requires a “cold” tap or a “hot” tap into an existing pipeline)

Both the in-line and insertion configurations are similar in that they both use identical electronics and have similar sensor heads. Besides installation differences, the main difference between an in-line flowmeter and an insertion flowmeter is their method of measurement.

For an in-line vortex flowmeter, the shedder bar is located across the entire diameter of the flow body. Thus, the entire pipeline flow is included in the vortex formation and measurement. The sensing head, which directly measures velocity, temperature and pressure is located just downstream of the shedder bar.

Insertion vortex flowmeters have a shedder bar located across the diameter of a short tube. The velocity, temperature and pressure sensor are located within this tube just downstream of a built-in shedder bar. This entire assembly is called the insertion sensing head. It fits through any entry port with a 47.625 mm (1.875”) minimum internal diameter.

The sensing head of an insertion vortex flowmeter directly monitors the velocity at a point in the cross-sectional area of a pipe, duct, or stack (referred to as “channels”). The velocity at a point in the pipe varies as a function of the Reynolds number. The insertion vortex flowmeter computes the Reynolds number and then computes the total flow rate in the channel. The output signal of insertion meters is the total flow rate in the channel. The accuracy of the total flow rate computation depends on adherence to the piping installation requirements given in Section 3. If adherence to those guidelines cannot be met, contact the factory for specific installation advice.

2.9 Multivariable options

The VLM20 or VIM20 models are available with the following options:

- V, volumetric flowmeter;
- VT, velocity and temperature sensors;
- VTP, velocity, temperature, and pressure sensors;
- VTEM energy output options;
- VTPM, energy options with pressure;
- VTEP, external pressure transmitter input.

2.10 Line size / process connections / materials

The VLM20 In-line model is built for line sizes DN15 (½") through DN100 (4") wafer or DN15 (½") through DN300 (12") flanged design using ANSI 150, 300, 600, PN40, PN100 class flanges.

The VIM20 Insertion model can be used in line sizes DN50 (2") and greater and is built with a compression fitting or packing gland design using DN50 (2") NPT, or DN50 (2") flanged connections (ANSI 150, 300, 600, PN16, PN40 and PN64 class flanges). The packing gland design can be ordered with a permanent or removable retractor.

The VLM20 In-line model can be built with A105 carbon steel, 316L stainless steel.
The VIM20 Insertion model can be built with 316L stainless steel.

2.11 Flowmeter electronics

Flowmeter electronics are available mounted directly to the flow body, or remotely mounted. The electronics housing may be used indoors or outdoors, including wet environments. Available input power options are: dc loop powered (2-wire), dc powered, or ac powered. Three analog output signals are available for your choice of three of the five process variables: mass flow rate, volumetric flow rate, temperature, pressure or fluid density. A pulse output signal for remote totalization and MODBUS or HART communications are also available.

Flowmeters include a local 2 x 16 character LCD display housed within the enclosure. Local operation and reconfiguration is accomplished using six pushbuttons operated via finger touch. For hazardous locations, the six buttons can be operated with the electronics enclosure sealed using a hand-held magnet, thereby not compromising the integrity of the hazardous location certification.

The electronics include nonvolatile memory that stores all configuration information. The nonvolatile memory allows the flowmeter to function immediately upon power up, or after an interruption in power. All flowmeters are calibrated and configured for the customer's flow application.

3. Installation

3.1 Installation overview

Spirax Sarco's Flowmeter installations are simple and straightforward.

Both the VLM20 In-Line and VIM20 Insertion type flowmeter installations are covered in this chapter. After reviewing the installation requirements given below, see page 16 for VLM20 installation instructions. See page 20 for VIM20 installation instructions. Wiring instructions begin on page 36.



Warning!

Consult the flowmeter nameplate for specific flowmeter approvals before any hazardous location installation.

3.2 Flowmeter installation requirements

Before installing the flowmeter, verify the installation site allows for these considerations:

1. Line pressure and temperature will not exceed the flowmeter rating.
2. The location meets the required minimum number of pipe diameters upstream and downstream of the sensor head as illustrated in Figure 4
3. Safe and convenient access with adequate overhead clearance for maintenance purposes.
4. Verify that the cable entry into the instrument meets the specific standard required for hazardous area installations.

The cable entry device shall be of a certified flameproof type, suitable for the conditions of use and correctly installed.

The degree of protection of at least IP66 to EN 60529 is only achieved if certified cable entries are used that are suitable for the application and correctly installed.

Unused apertures shall be closed with suitable blanking elements.

5. For remote installations, verify the supplied cable length is sufficient to connect the flowmeter sensor to the remote electronics.

Also, before installation check your flow system for anomalies such as:

- leaks
- valves or restrictions in the flow path that could create disturbances in the flow profile that might cause unexpected flow rate indications

3.3 Unobstructed flow requirements

Select an installation site that will minimize possible distortion in the flow profile. Valves, elbows, control valves and other piping components may cause flow disturbances. Check your specific piping condition against the examples shown below. In order to achieve accurate and repeatable performance install the flowmeter using the recommended number of straight run pipe diameters upstream and downstream of the sensor.

Note: For liquid applications in vertical pipes, avoid installing with flow in the downward direction because the pipe may not be full at all points.

Choose to install the meter with flow in the upward direction if possible.

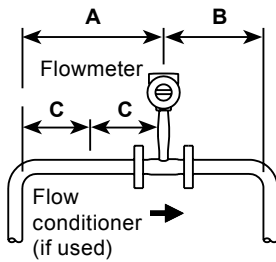

Example 1
One 90° elbow before the flowmeter

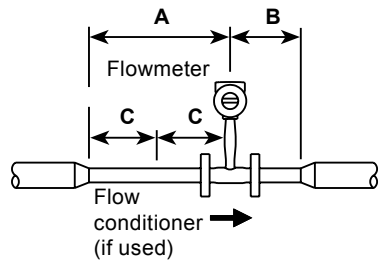

Example 4
Reduction before the flowmeter

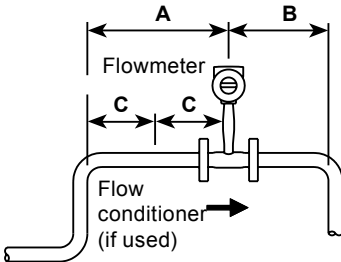

Example 2
Two 90° elbow before the flowmeter in one plane

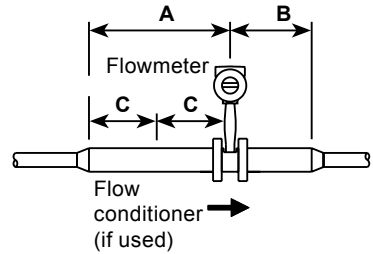

Example 5
Expansion before the flowmeter

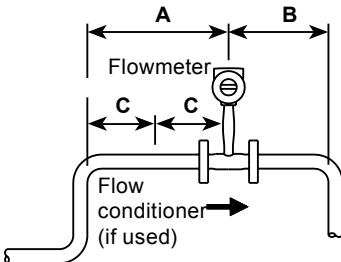

Example 3
Two 90° elbow before the flowmeter out of plane (if there are three 90° bends present, double the recommended length)

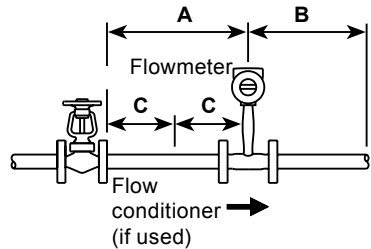

Example 6
If the regulator or valve is partially closed before the flowmeter (If the valve is always wide open, base the pipe length requirements on fitting preceding it)

Fig. 4
Recommended pipe length requirements for Installation

D = Internal diameter of channel.

N/A = Not applicable

Example	Minimum required upstream diameters				Minimum required downstream diameters	
	No flow conditioner	With flow conditioner			With flow conditioner	No flow conditioner
		A	A	C		
1	10 D	N/A	N/A	N/A	5 D	5 D
2	15 D	10 D	5 D	5 D	5 D	5 D
3	25 D	10 D	5 D	5 D	10 D	5 D
4	10 D	10 D	5 D	5 D	5 D	5 D
5	20 D	10 D	5 D	5 D	5 D	5 D
6	25 D	10 D	5 D	5 D	10 D	5 D

3.4 VLM20 in-line flowmeter installation

Install the VLM20 In-Line Flowmeter between two conventional pipe flanges as shown in Figures 6 and 7. Table 1 provides the recommended minimum stud bolt lengths for wafer-style meter body size and different flange ratings.

The meter inside diameter is equal to the same size nominal pipe ID in schedule 80. For example, a DN50 (2") meter has an ID of 49.251 mm (1.939") (DN50 (2") schedule 80). **Do not install the meter in a pipe with an inside diameter smaller than the inside diameter of the meter.** For schedule 160 and higher pipe, a special meter is required. Consult the factory before purchasing the meter.

VLM20 Meters require customer-supplied gaskets. When selecting gasket material make sure that it is compatible with the process fluid and pressure ratings of the specific installation. Verify that the inside diameter of the gasket is larger than the inside diameter of the flowmeter and adjacent piping. If the gasket material extends into the flow stream, it will disturb the flow and cause inaccurate measurements.

3.4.1 Flange bolt specifications

Line size	Stud bolt lengths for each flange rating		
	Class 150	Class 300 and PN40	Class 600 and PN100
DN25 (1")	152.40 mm (6.00")	177.80 mm (7.00")	190.50 mm (7.50)
DN40 (1.5")	158.75 mm (6.25")	215.90 mm (8.50")	228.60 mm (9.00")
DN50 (2")	215.90 mm (8.50")	222.25 mm (8.75")	241.30 mm (9.50")
DN80 (3")	228.60 mm (9.00")	254.00 mm (10")	266.70 mm (10.50")
DN100 (4")	241.30 mm (9.50")	273.05 mm (10.75")	311.75 mm (12.25")

Table 1. Minimum recommended stud bolt lengths for wafer meters

The required bolt load for sealing the gasket joint is affected by several application-dependent factors, therefore the required torque for each application may be different. Refer to the ASME Pressure Vessel Code guidelines for bolt tightening standards.

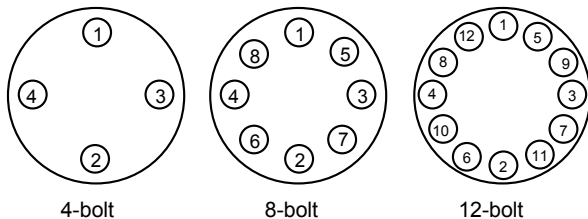

Fig. 5
Flange bolt torquing sequence

3.5 Wafer-style flowmeter installation

Install the wafer-style meter between two conventional pipe flanges of the same nominal size as the flowmeter. If the process fluid is a liquid, make sure the meter is located where the pipe is always full. This may require locating the meter at a low point in the piping system. Note: Vortex flowmeters are not suitable for two-phase flows (i.e., liquid and gas mixtures). For horizontal pipelines having a process temperature above 300 °F, mount the meter at a 45 or 90-degree angle to avoid overheating the electronics enclosure. To adjust the viewing angle of the enclosure or display/keypad, see pages 34 and 35.

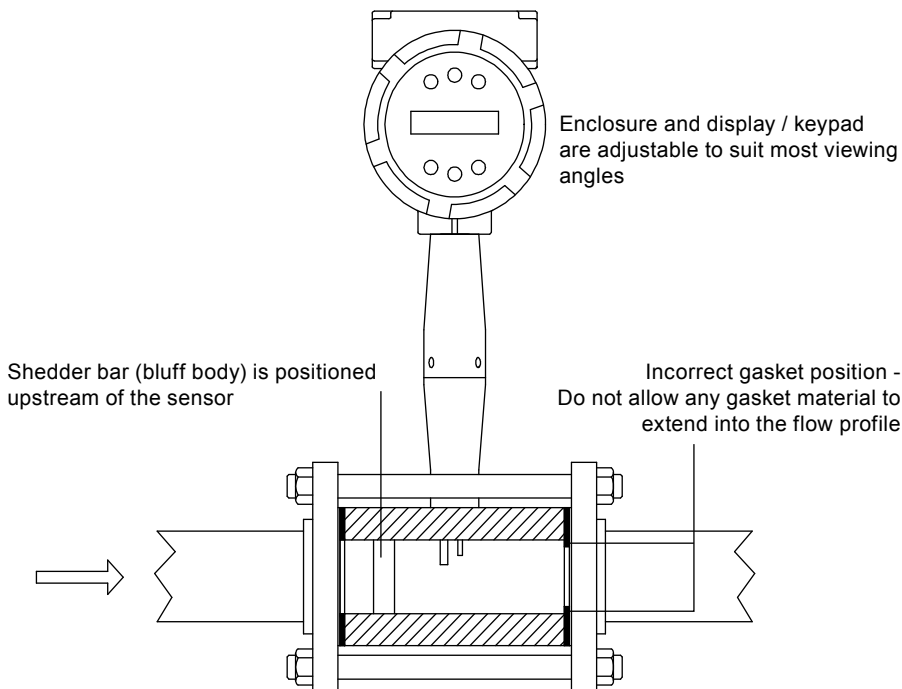

Fig. 6 Wafer-style flowmeter installation



Caution!

When using toxic or corrosive gases, purge the line with inert gas for a minimum of four hours at full gas flow before installing the flowmeter.

When installing the meter make sure the section marked with a flow arrow is positioned upstream of the outlet, with the arrow head pointing in the direction of flow. (The mark is on the wafer adjacent to the enclosure mounting neck.) This ensures that the sensor head is positioned downstream of the vortex shedder bar and is correctly aligned to the flow. Installing the meter opposite this direction will result in completely inaccurate flow measurement. To install the meter:

1. Turn off the flow of process gas, liquid or steam. Verify that the line is not pressurized. Confirm that the installation site meets the required minimum upstream and downstream pipe diameters.
2. Insert the studs for the bottom side of the meter body between the pipe flanges. Place the wafer-style meter body between the flanges with the end stamped with a flow arrow on the upstream side, with the arrow head pointing in the direction of flow. Center the meter body inside the diameter with respect to the inside diameter of the adjoining piping.
3. Position the gasket material between the mating surfaces. Make sure both gaskets are smooth and even with no gasket material extending into the flow profile. Obstructions in the pipeline will disturb the flow and cause inaccurate measurements.
4. Place the remaining studs between the pipe flanges. Tighten the nuts in the sequence shown in Figure 6. Check for leaks after tightening the flange bolts

3.6 Flange-style flowmeter installation

Install the flange-style meter between two conventional pipe flanges of the same nominal size as the flowmeter. If the process fluid is a liquid, make sure the meter is located where the pipe is always full. This may require locating the meter at a low point in the piping system. Note: Vortex flowmeters are not suitable for two-phase flows (i.e., liquid and gas mixtures). For horizontal pipelines having a process temperature above 300 °F, mount the meter at a 45 or 90-degree angle to avoid overheating the electronics enclosure. To adjust the viewing angle of the enclosure or display/keypad, see pages 34 and 35.

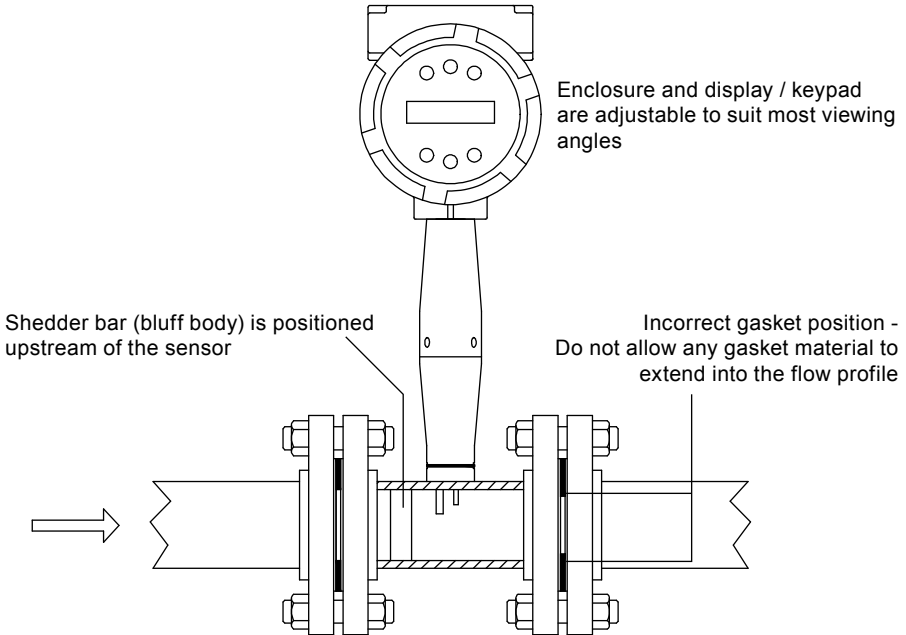

Fig. 7 Flange-style flowmeter installation



Caution!

When using toxic or corrosive gases, purge the line with inert gas for a minimum of four hours at full gas flow before installing the flowmeter.

When installing the meter make sure the flange marked with a flow arrow is positioned upstream of the outlet flange, with the arrow head pointing in the direction of flow. (The mark is on the flange adjacent to the enclosure mounting neck.) This ensures that the sensor head is positioned downstream of the vortex shedder bar and is correctly aligned to the flow. Installing the meter opposite this direction will result in completely inaccurate flow measurement. To install the meter:

1. Turn off the flow of process gas, liquid or steam. Verify that the line is not pressurized. Confirm that the installation site meets the required minimum upstream and downstream pipe diameters.
2. Seat the meter level and square on the mating connections with the flange stamped with a flow arrow on the upstream side, with the arrow head pointing in the direction of flow. Position a gasket in place for each side. Make sure both gaskets are smooth and even with no gasket material extending into the flow profile. Obstructions in the pipeline will disturb the flow and cause inaccurate measurements.
3. Install bolts in both process connections. Tighten the nuts in the sequence shown in Figure 5. Check for leaks after tightening the flange bolts.

3.7 Insertion flowmeter installation

Prepare the pipeline for installation using either a cold tap or hot tap method described on the following pages. Refer to a standard code for all pipe tapping operations. The following tapping instructions are general in nature and intended for guideline purposes only. Before installing the meter, review the mounting position and isolation valve requirements given below.

3.7.1 Mounting position

Allow clearance between the electronics enclosure top and any other obstruction when the meter is fully retracted.

3.7.2 Isolation valve selection

An isolation valve is available as an option with VIM20 meters. If you supply the isolation valve, it must meet the following requirements:

1. A minimum valve bore diameter of 47.625 mm (1.875") is required, and the valve's body size should be DN50 (2"). Normally, gate valves are used.
2. Verify that the valve's body and flange rating are within the flowmeter's maximum operating pressure and temperature.
3. Choose an isolation valve with at least 47.625 mm (1.875") existing between the flange face and the gate portion of the valve. This ensures that the flowmeter's sensor head will not interfere with the operation of the isolation valve.

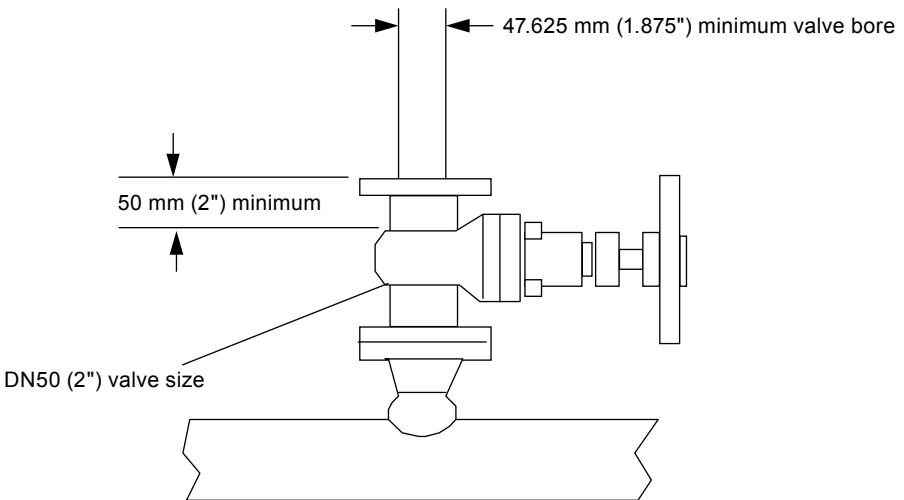

Fig. 8 Isolation valve requirements

3.8 Cold tap guidelines

Refer to a standard code for all pipe tapping operations. The following tapping instructions are general in nature and intended for guideline purposes only.



Caution!

When using toxic or corrosive gases, purge the line with inert gas for a minimum of four hours at full gas flow before installing the flowmeter.



Warning!

All flowmeter connections, isolation valves and fittings for cold tapping must have the same or higher pressure rating as the main pipeline.

1. Turn off the flow of process gas, liquid or steam. Verify that the line is not pressurized.
2. Confirm that the installation site meets the minimum upstream and downstream pipe diameter requirements. See Figure 4.
3. Use a cutting torch or sharp cutting tool to tap into the pipe. The pipe opening must be at least 47.625 mm (1.875") in diameter. (Do not attempt to insert the sensor probe through a smaller hole.)
4. Remove all burrs from the tap. Rough edges may cause flow profile distortions that could affect flowmeter accuracy. Also, obstructions could damage the sensor assembly when inserting into the pipe.
5. After cutting, measure the thickness of the cut-out and record this number for calculating the insertion depth.
6. Weld the flowmeter pipe connection on the pipe. Make sure this connection is within $\pm 5^\circ$ of perpendicular to the pipe centre line.
7. Install the isolation valve (if used).
8. When welding is complete and all fittings are installed, close the isolation valve or cap the line. Run a static pressure check on the welds. If pressure loss or leaks are detected, repair the joint and retest.
9. Connect the meter to the pipe process connection.
10. Calculate the sensor probe insertion depth and insert the sensor probe into the pipe as described on the following pages.

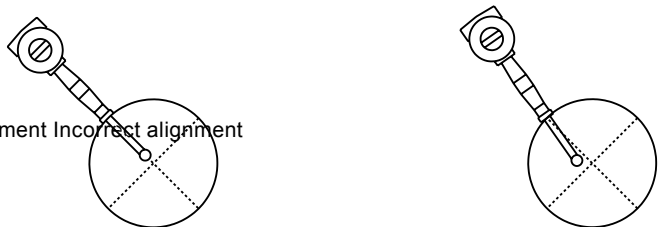

Fig. 9 Correct alignment Incorrect alignment

3.9 Hot tap guidelines

Refer to a standard code for all pipe tapping operations. The following tapping instructions are general in nature and intended for guideline purposes only.



Warning!

Hot tapping must be performed by a trained professional. US. regulations often require a hot tap permit. The manufacturer of the hot tap equipment and/or the contractor performing the hot tap is responsible for providing proof of such a permit.





Warning!

All flowmeter connections, isolation valves, and fittings for hot tapping must have the same or higher pressure rating as the main pipeline.

1.	Confirm that the installation site meets the minimum upstream and downstream pipe diameter requirements.
2.	Weld a 50.8 mm (2") mounting adapter on the pipe. Make sure the mounting adapter is within $\pm 5^\circ$ of perpendicular to the pipe centerline (see previous page). The pipe opening must be at least 47.625 mm (1.875") in diameter.
3.	Connect a 50.8 mm (2") process connection on the mounting adapter.
4.	Connect an isolation valve on the process connection. The valve is full open bore must be at least 47.625 mm (1.875") in diameter.
5.	Run a static pressure check on the welds. If pressure loss or leaks are detected, repair the joint and re-test.
6.	Connect the hot tapping equipment to the isolation valve, open the isolation valve and drill at least a 47.625 mm (1.875") diameter hole.
7.	Retract the drill, close the isolation valve, and remove the hot tapping equipment.
8.	Connect the flowmeter to the isolation valve and open the isolation valve.
9.	Calculate the sensor probe insertion depth and insert the sensor probe into the pipe as described on the following pages.

 Check upstream and downstream requirements

 Weld mounting adapter

 Connect process connection (flange or NPT)

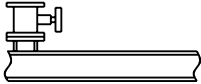
 Connect isolation valve and test for leaks

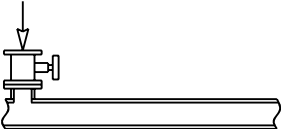
 Hot tap pipe

 Purge pipe

 Connect meter to valve, calculate insertion depth, install flowmeter

Fig. 10 Hot tap sequence

3.10 Flowmeter insertion

The sensor head must be properly positioned in the pipe. For this reason, it is important that insertion length calculations are carefully followed. A sensor probe inserted at the wrong depth in the pipe will result in inaccurate readings.

Insertion flowmeters are applicable to pipes DN50 (2") and larger. For pipe sizes DN250 (10") and smaller, the centerline of the meter's sensing head is located at the pipe's centerline. For pipe sizes larger than DN250 (10"), the centerline of the sensing head is located in the pipe's cross section 127 mm (5") from the inner wall of the pipe; i.e., its depth from the wall to the centerline of the sensing head is 127 mm (5").

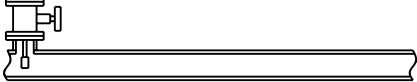
Insertion flowmeters are available in three probe lengths:

Standard Probe configuration is used with most flowmeter process connections. The length, S, of the stem is 748.54 mm (29.47").

Compact Probe configuration is used with compression fitting process connections. The length, S, of the stem is 332.74 mm (13.1").

304.8 mm (12") Extended Probe configuration is used with exceptionally lengthy flowmeter process connections. The length, S, of the stem is 1 053.34 mm (41.47").

3.10.1 Use the correct Insertion formula



Warning!

An Insertion tool must be used for any installation where a flowmeter is inserted under pressure greater than 3.45 bar g (50 psi g).

Depending on your flowmeters process connection, use the applicable insertion length formula and installation procedure as follows:

- Flowmeters with a compression type connection (NPT or flanged) follow the instructions beginning on page 25.
- Flowmeters with a packing gland type connection (NPT or flanged) configured with an insertion tool, follow the instructions beginning on page 27.
- Flowmeters with a packing gland type connection (NPT or flanged) without an insertion tool, follow the instructions beginning on page 32.

3.11 Installing flowmeters with a compression connection*

Use the following formula to determine insertion length for flowmeters (NPT and flanged) with a compression process connection. The installation procedure is given on the next page.

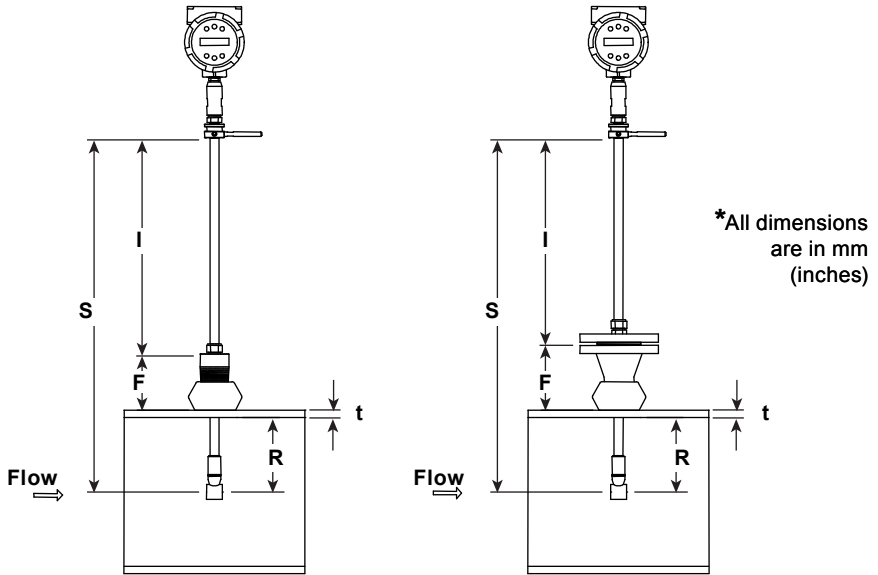

Insertion length formula

$$I = S - F - R - t$$

Where:

- I = insertion length.
- S = Stem length - the distance from the center of the sensor head to the base of the enclosure adapter
 S = 748.54 mm (29.47") for standard probes;
 S = 332.74 mm (13.1") for compact;
 S = 1 053.34 mm (41.47") for 304.8 mm (12") extended).
- F = Distance from the raised face of the flange or top of NPT stem housing to the outside of the pipe wall.
- R = Pipe inside diameter ÷ 2 for pipes DN250 (10") and smaller.
 R = 127 mm (5") for pipe diameters larger than DN250 (10").
- t = Thickness of the pipe wall. (Measure the disk cut-out from the tapping procedure or check a piping handbook for thickness.)

Fig. 11 Insertion calculation (compression type)

Example:

To install a VIM20 meter with a standard probe (S = 748.54 mm (29.47")) into a DN350 (14") schedule 40 pipe, the following measurements are taken:

$$F = 76.2 \text{ mm (3") } R = 127 \text{ mm (5") } t = 11.125 \text{ mm (0.438")}$$

The insertion length for this example is 534.16 mm (21.03"). Insert the stem through the fitting until an insertion length of 534.16 mm (21.03") is measured with a ruler.

3.11.1 Insertion procedure for meters with a compression connection

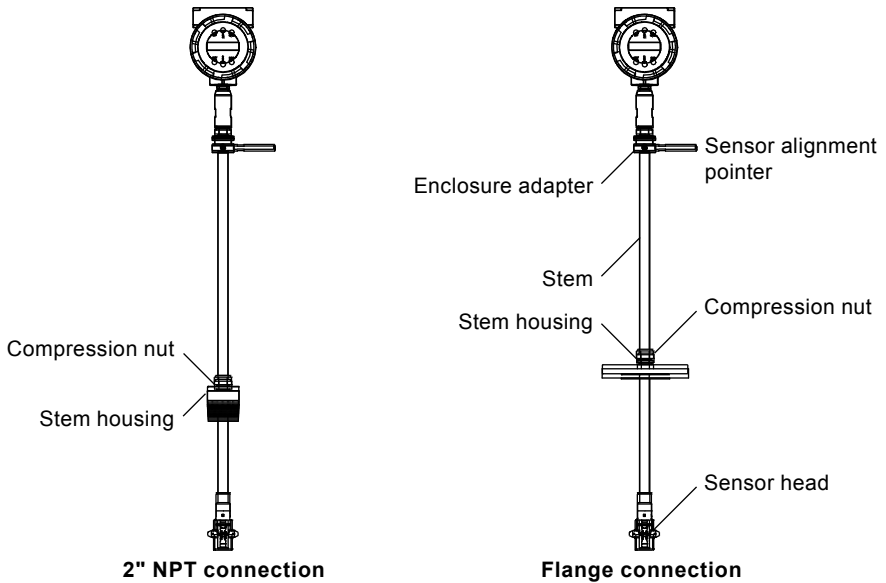

Fig. 12 Flowmeter with compression type fitting



Caution!

The sensor alignment pointer must point downstream, in the direction of flow.



Warning!

To avoid serious injury, **DO NOT** loosen the compression fitting under pressure.

1. Calculate the required sensor probe insertion length.
2. Fully retract the stem until the sensor head is touching the bottom of the stem housing. Slightly tighten the compression nut to prevent slippage.
3. Bolt or screw the flowmeter assembly into the process connection. Use Teflon tape or pipe sealant to improve the seal and prevent seizing on NPT styles.
4. Hold the meter securely while loosening the compression fitting. Insert the sensor into the pipe until the calculated insertion length, l , is measured between the base of the enclosure adapter and the top of the stem housing, or to the raised face of the flanged version. Do not force the stem into the pipe.
5. Align the sensor head using the sensor alignment pointer. Adjust the alignment pointer parallel to the pipe and pointing downstream.
6. Tighten the compression fitting to lock the stem in position. **When the compression fitting is tightened, the position is permanent.**

3.12 Installing flowmeters with a packing gland connection*

Use the formula below to determine the insertion depth for flowmeters (NPT and flanged) equipped with an insertion tool. To install, see the next page for instructions for meters with a permanent insertion tool. For meters with a removable insertion tool, see page 27.

Insertion length formula

$$I = F + R + t - 34.29 \text{ mm (1.35")}$$

Where:

- I = Insertion length.
- F = Distance from the raised face of the flange or top of the process connection for NPT style meters to the top outside of the process pipe.
- R = Pipe inside diameter ÷ 2 for pipes DN250 (10") and smaller.
R = 127 mm (5") for pipe diameters larger than DN250 (10").
- t = Thickness of the pipe wall. (Measure the disk cutout from the tapping procedure or check a piping handbook for thickness.)

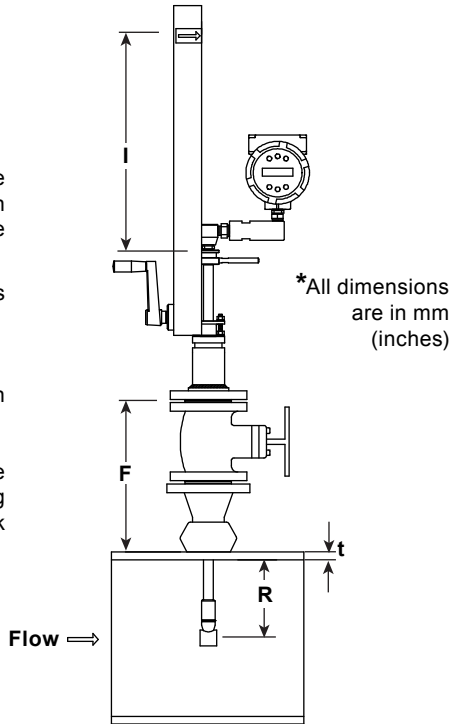

Fig. 13 Insertion calculation (Meters with insertion tool)

Example 1: Flange Style Meters:

To install a VIM20 Flowmeter into a DN350 (14") schedule 40 pipe, the following measurements are taken:

$$F = 304.8 \text{ mm (12") } R = 127 \text{ mm (5") } t = 11.125 \text{ mm (0.438")}$$

The example insertion length is 408.68 mm (16.09").

Example 2: NPT Style Meters:

The length of thread engagement on the NPT style meters is also subtracted in the equation. The length of the threaded portion of the NPT meter is 29.97 mm (1.18"). Measure the thread portion still showing after the installation and subtract that amount from 29.97 mm (1.18"). This gives you the thread engagement length. If this cannot be measured use 13.97 mm (0.55") for this amount.

$$F = 304.8 \text{ mm (12") } R = 127 \text{ mm (5") } t = 11.125 \text{ mm (0.438")}$$

The example insertion length is 394.72 mm (15.54").

3.12.1 Insertion procedure for flowmeters with permanent Insertion tool

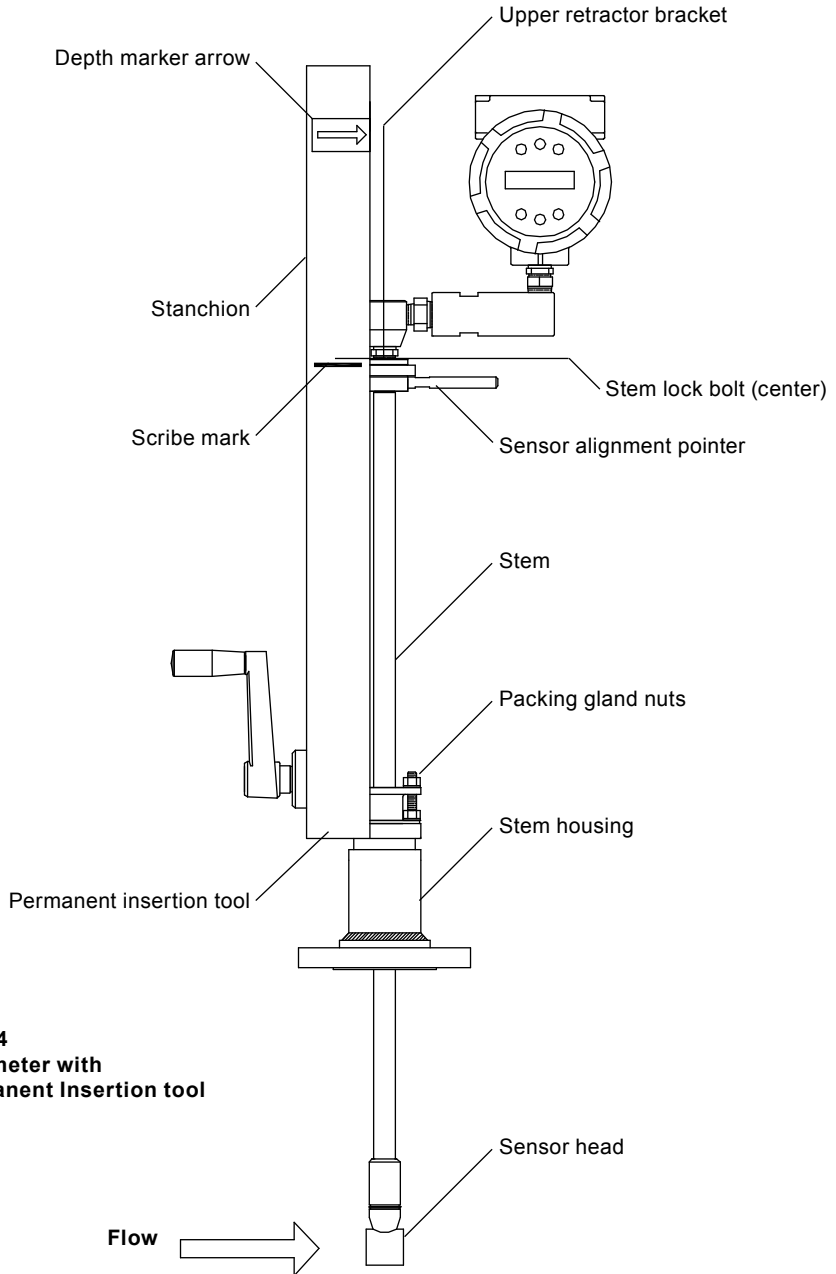

Fig. 14
Flowmeter with
permanent Insertion tool



Caution!

The sensor alignment pointer must point downstream, in the direction of flow.



Note

If line pressure is above 34.47 bar g (500 psi g), it could require up to 33.895 N-m (25 ft-lb) of torque to insert the flowmeter.

Do not confuse this with possible interference in the pipe.

1. Calculate the required sensor probe insertion length (see previous page). Measure from the depth marker arrow down the stanchion and scribe a mark at the calculated insertion depth.
2. Fully retract the flowmeter until the sensor head is touching the bottom of the stem housing. Attach the meter assembly to the DN50 (2") full-port isolation valve, if used. Use Teflon tape or pipe sealant to improve seal and prevent seizing on NPT style.
3. Loosen the two packing gland nuts on the stem housing of the meter.

Loosen the stem lock bolt adjacent to the sensor alignment pointer. Align the sensor head using the sensor alignment pointer. Adjust the alignment pointer parallel to the pipe and pointing downstream. Tighten the stem lock bolt to secure the sensor position.

4. Slowly open the isolation valve to the full open position. If necessary, slightly tighten the two packing gland nuts to reduce the leakage around the stem.
5. Turn the insertion tool handle clockwise to insert the sensor head into the pipe. Continue until the top of the upper retractor bracket aligns with the insertion length position scribed on the stanchion. Do not force the stem into the pipe.
6. Tighten the packing gland nuts to stop leakage around the stem. Do not torque over 27.116 N-m (20 ft-lb).

3.12.2 Insertion procedure for flowmeters with removable insertion tool

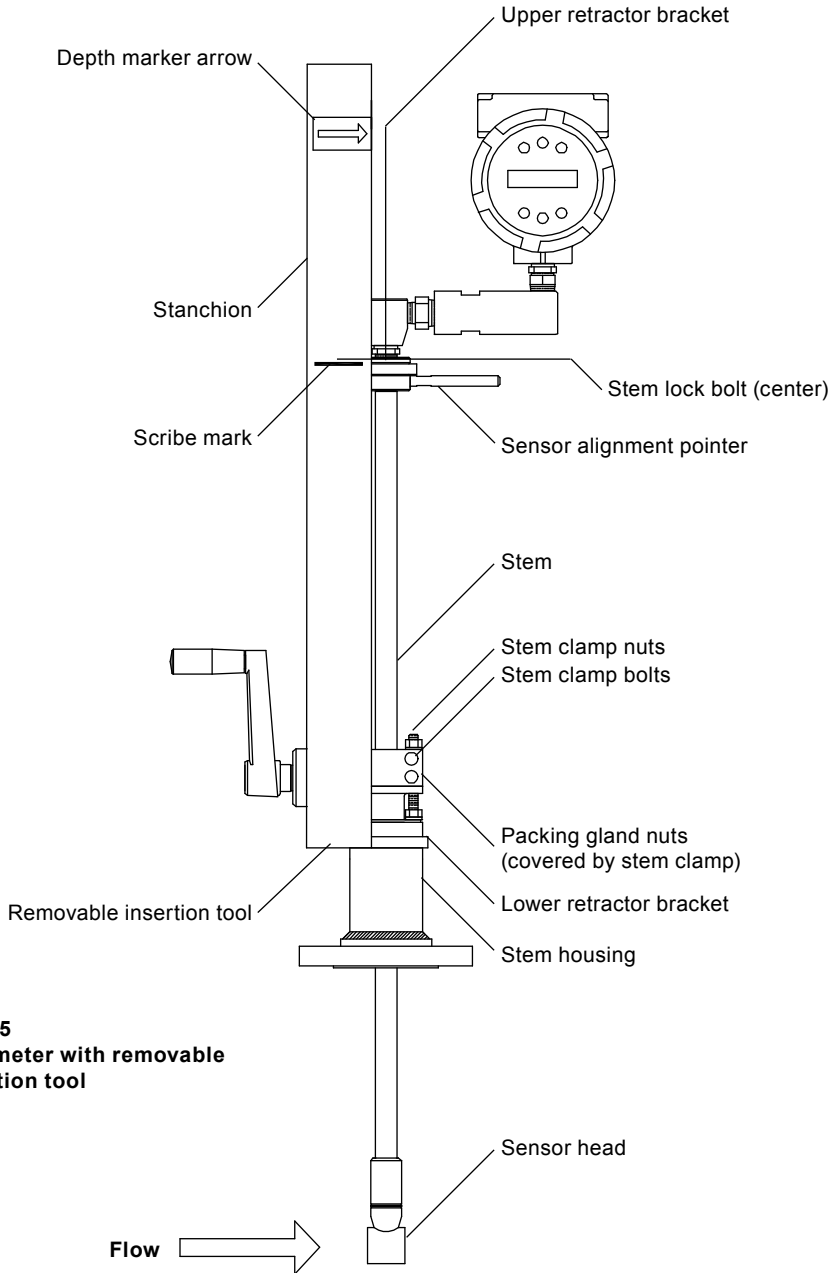

Fig. 15
Flowmeter with removable
insertion tool



Caution!

The sensor alignment pointer must point downstream, in the direction of flow.



Note

If line pressure is above 34.473 bar g (500 psi g), it could require up to 33.895 N-m (25 ft-lb) of torque to insert the flowmeter.

Do not confuse this with possible interference in the pipe.

1. Calculate the required sensor probe insertion length. Measure from the depth marker arrow down the stanchion and scribe a mark at the calculated insertion depth.
2. Fully retract the flowmeter until the sensor head is touching the bottom of the stem housing. Attach the meter assembly to the DN50 (2") full-port isolation valve, if used. Use Teflon tape or pipe sealant to improve seal and prevent seizing on NPT style.
3. Remove the two top stem clamp nuts and loosen two stem clamp bolts. Slide the stem clamp away to expose the packing gland nuts.
4. Loosen the two packing gland nuts. Loosen the stem lock bolt adjacent to the sensor alignment pointer. Align the sensor head using the sensor alignment pointer. Adjust the alignment pointer parallel to the pipe and pointing downstream. Tighten the stem lock bolt to secure the sensor position.
5. Slowly open the isolation valve to the full open position. If necessary, slightly tighten the two packing gland nuts to reduce the leakage around the stem.
6. Turn the insertion tool handle clockwise to insert the stem into the pipe. Continue until the top of the upper retractor bracket lines up with the insertion length mark scribed on the stanchion. Do not force the stem into the pipe.
7. Tighten the packing gland nuts to stop leakage around the stem. Do not torque over 33.895 N-m (20 ft-lbs).
8. Slide the stem clamp back into position. Torque stem clamp bolts to 20.38 N-m (15 ft-lbs). Replace the stem clamp nuts and torque to 13.56-20.34 N-m (10-15 ft-lbs).
9. To separate the insertion tool from the flowmeter, remove four socket head cap bolts securing the upper and lower retractor brackets. Remove the insertion tool.

3.13 Installation of meters with packing gland connection (No Insertion Tool)*

Use the following formula to determine insertion depth for meters with a packing gland connection (NPT and flanged) without an insertion tool.

Insertion length formula

$$I = S - F - R - t$$

Where:

I = Insertion length.

S = Stem length - the distance from the center of the sensor head to the base of the enclosure adapter

S = 748.54 mm (29.47") for standard probes;

S = 1 053.34 mm (41.47") for 304.8 mm (12") extended probes.

F = Distance from the raised face of the flange or top of NPT stem housing to the outside of the pipe wall.

R = Pipe inside diameter ÷ 2 for pipes DN250 (10") and smaller.

R = 127 mm (5") for pipe diameters larger than DN250 (10").

t = Thickness of the pipe wall.
(Measure the disk cut-out from the tapping procedure or check a piping handbook for thickness.)

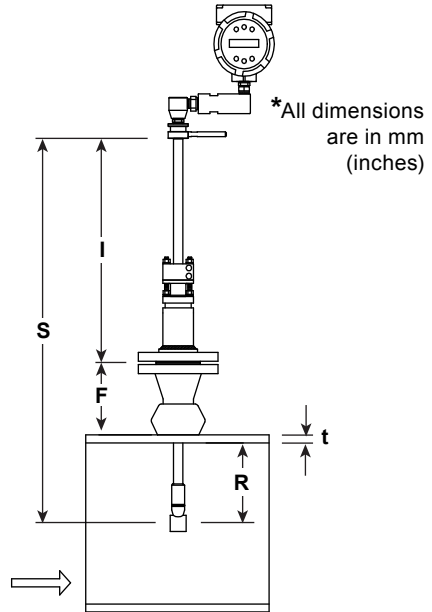

Fig. 16 Insertion calculation (Meters without insertion tool)

Example:

To install a VIM20 Flowmeter with a standard probe (748.54 mm (29.47")) into a DN350 (14") schedule 40 pipe, the following measurements are taken:

$$F = 76.2 \text{ mm (3")} \quad R = 127 \text{ mm (5")} \quad t = 11.125 \text{ mm (0.438")}$$

The example insertion length is 534.16 mm (21.03").

3.13.1 Insertion procedure for flowmeters with no insertion tool (Packing gland connection)



Warning!

The line pressure must be less than 3.48 bar g (50 psi g) for installation.



Caution!

The sensor alignment pointer must point downstream, in the direction of flow.

1. Calculate the required sensor probe insertion length.
2. Fully retract the stem until the sensor head is touching the bottom of the stem housing. Remove the two top stem clamp nuts and loosen two stem clamp bolts. Slide the stem clamp away to expose the packing gland nuts. Loosen the two packing gland nuts.
3. Align the sensor head using the sensor alignment pointer. Adjust the alignment pointer parallel to the pipe and pointing downstream.
4. Insert the sensor head into the pipe until insertion length, l , is achieved. Do not force the stem into the pipe.
5. Tighten the packing gland nuts to stop leakage around the stem. Do not torque over 27.116 N-m (20 ft-lbs).
6. Slide the stem clamp back into position. Torque stem clamp bolts to 20.337 N-m (15 ft-lbs). Replace the stem clamp nuts and torque to 13.56-20.337 N-m (10-15 ft-lbs).

3.14 Adjusting meter orientation

Depending on installation requirements, you may need to adjust the meter orientation. There are two adjustments available. The first rotates the position of the LCD display/keypad and is available on both in-line and insertion meters. The second is to rotate the enclosure position. This adjustment is only allowed on VLM20 In-Line meters.

3.15 Display / keypad adjustment (All meters)

The orientation of the display / keypad may be changed in 90° increments for easier viewing.

Fig. 17
Display / keypad
viewing adjustment

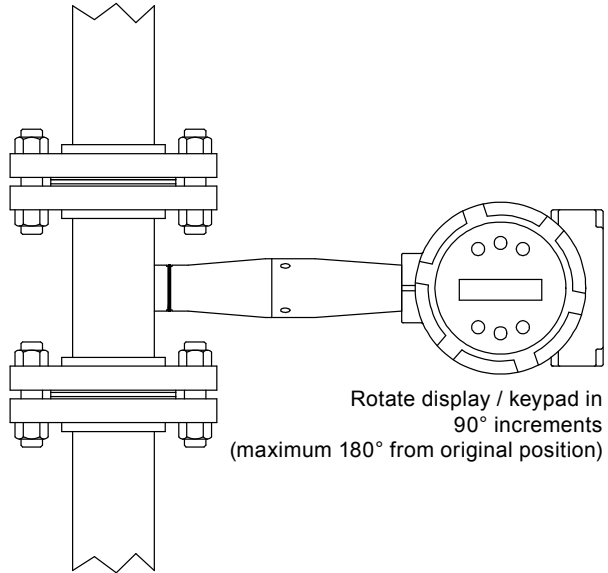

The electronics boards are electrostatically sensitive. Wear a grounding wrist strap and make sure to observe proper handling precautions required for static-sensitive components. To adjust the display:

1. Disconnect power to the flowmeter.
2. Loosen the small set screw which secures the electronics enclosure cover. Unscrew and remove the cover.
3. Loosen the 4 captive screws.
4. Carefully pull the display/microprocessor board away from the meter standoffs. Make sure not to damage the connected ribbon cable.
5. Rotate the display/microprocessor board to the desired position. Maximum turn, two positions left or two positions right (180°).
6. Align the board with the captive screws. Check that the ribbon cable is folded neatly behind the board with no twists or crimps.
7. Tighten the screws. Replace the cover and set screw. Restore power to the meter.

3.16 Enclosure adjustment (VLM20 Only)

Fig. 18
Enclosure Viewing
Adjustment

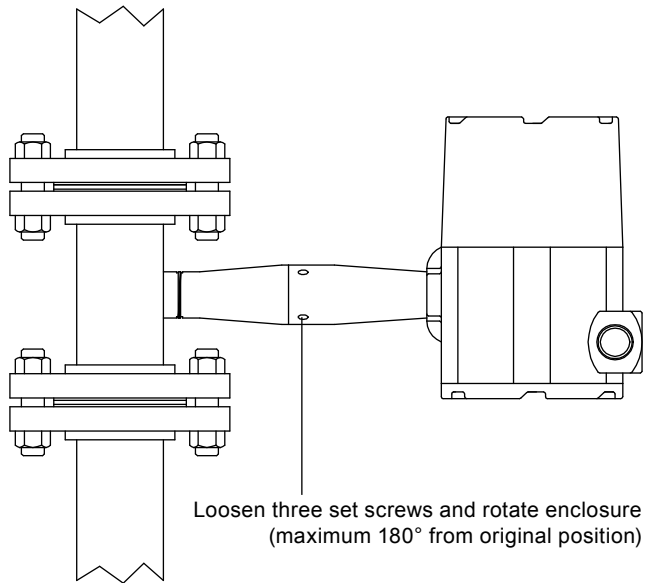

To avoid damage to the sensor wires, do not rotate the enclosure beyond 180° from the original position. To adjust the enclosure:

1. Remove power to the flowmeter.
2. Loosen the three set screws shown above. Rotate the display to the desired position (maximum 180°).
3. Tighten the three set screws. Restore power to the meter.

3.17 Loop power flowmeter wiring connections



Warning!

To avoid potential electric shock, follow National Electric Code safety practices or your local code when wiring this unit to a power source and to peripheral devices. Failure to do so could result in injury or death. All wiring procedures must be performed with the power off.

The NEMA 4X enclosure contains an integral wiring compartment with one dual strip terminal block (located in the smaller end of the enclosure). Two 3/4" female NPT conduit entries are available for separate power and signal wiring. For all hazardous area installations, make sure to use an agency-approved fitting at each conduit entry. The cable entry device shall be of a certified flameproof type, suitable for the conditions of use and correctly installed. The degree of protection of at least IP66 to EN 60529 is only achieved if certified cable entries are used that are suitable for the application and correctly installed. Unused apertures shall be closed with suitable blanking elements. If conduit seals are used, they must be installed within 457 mm (18") of the enclosure.

Fig. 19 Loop power wiring terminals

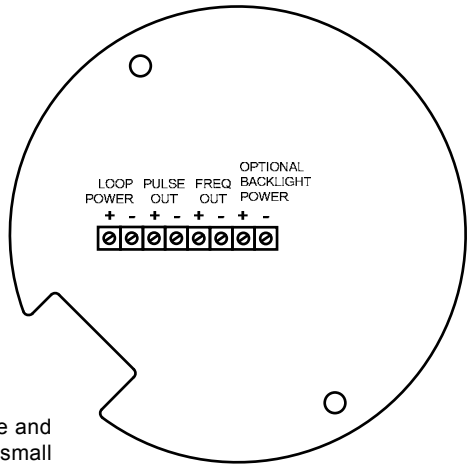

3.18 Input power connections

To access the wiring terminal blocks, locate and loosen the small set screw which locks the small enclosure cover in place. Unscrew the cover to expose the terminal block.

3.18.1 dc power wiring

Connect 4-20 mA loop power (12 to 36 Vdc at 25 mA, 1W max.) to the +Loop Power and Loop Power terminals on the terminal block.

Torque all connections to 0.5 to 0.6 N-m (4.43 to 5.31 in-lbs). The dc power wire size must be 20 to 10 AWG with the wire stripped 7 mm (0.25").

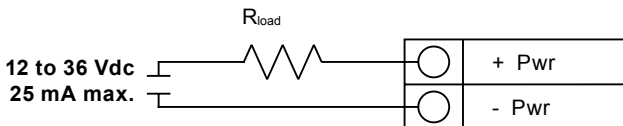

Fig. 20 dc power connections

3.19 4-20 mA output connections

The meter has a single 4-20 mA loop. The 4-20 mA loop current is controlled by the meter electronics. The electronics must be wired in series with the sense resistor or current meter. The current control electronics require 12 volts at the input terminals to operate correctly.

The maximum loop resistance (load) for the current loop output is dependent upon the supply voltage and is given in Figure 21. The 4-20 mA loop is optically isolated from the flowmeter electronics.

R_{load} is the total resistance in the loop, including the wiring resistance ($R_{load} = R_{wire} + R_{sense}$). To calculate R_{max} , the maximum R_{load} for the loop, subtract the minimum terminal voltage from the supply voltage and divide by the maximum loop current, 20 mA. Thus:

$$\text{The maximum resistance } R_{load} = R_{max} = (V_{supply} - 12V) / 0.020 \text{ A}$$

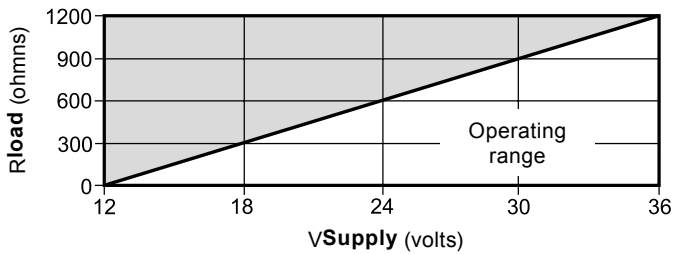

Fig. 21 Load Resistance Versus Input Voltage

3.20 Pulse output connections

The pulse output is used for a remote counter. When the preset volume or mass (defined in the totalizer settings, see Section 4) has passed the meter, the output provides a 50 millisecond square pulse.

The pulse output requires a separate 5 to 36 Vdc power supply. The pulse output optical relay is a normally-open single-pole relay. The relay has a nominal 200 volt/160 ohm rating. This means that it has a nominal on-resistance of 160 ohms, and the largest voltage that it can withstand across the output terminals is 200 volts. However, there are current and power specifications that must be observed. The relay can conduct a current up to 40 mA and can dissipate up to 320 mW. The relay output is isolated from the meter electronics and power supply.

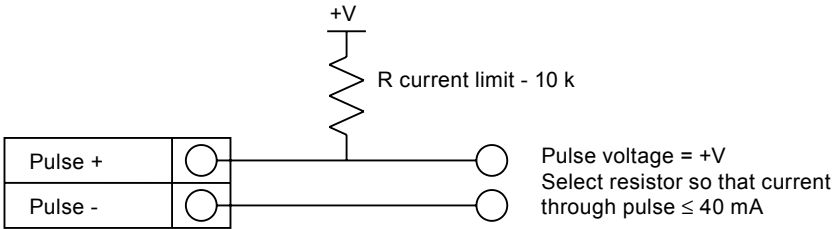

Fig. 22 Isolated pulse output using external power

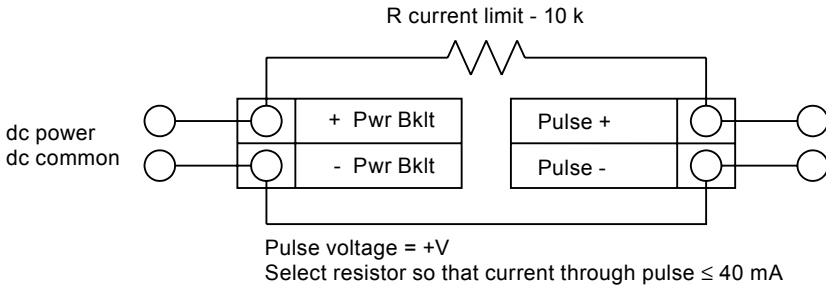

Fig. 23 Non-isolated pulse output using external power supply

3.21 Frequency output connections

The frequency output is used for a remote counter. It can be scaled to output a 1 to 10 kHz signal proportional to mass or volume flow, temperature, pressure or density.

The frequency output requires a separate 5 to 36 Vdc power supply; however, there are current and power specifications that must be observed.

The output can conduct a current up to 40 mA and can dissipate up to 200 mW. The output is isolated from the meter electronics and power supply.

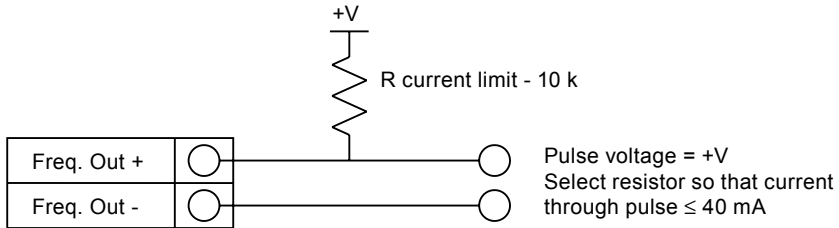

Fig. 24 Isolated pulse output using external power

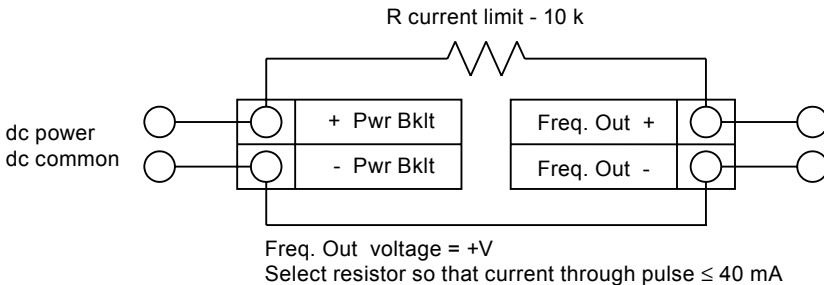

Fig. 25 Non-Isolated frequency output using external power supply

3.22 Optional backlight connection

The loop power meter has an optional backlight connection provided. It is intended to be powered by a separate 12 to 36 Vdc at 35 mA max. power supply or by the pulse power input. Both options are shown below.

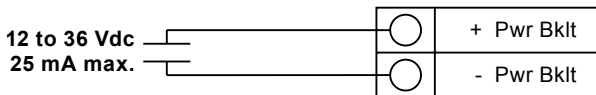

Fig. 26 Backlight using external power supply

3.23 Remote electronics wiring

The remote electronics enclosure should be mounted in a convenient, easy to reach location. For hazardous location installations, make sure to observe agency requirements for installation. Allow some slack in the interface cable between the junction box and the remote electronics enclosure. To prevent damage to the wiring connections, do not put stress on the terminations at any time.

The meter is shipped with temporary strain relief glands at each end of the cable. Disconnect the cable from the terminal block inside the junction box at the remote electronics enclosure. Remove both glands and install appropriate conduit entry glands and conduit. The cable entry device shall be of a certified flameproof type, suitable for the conditions of use and correctly installed. The degree of protection of at least IP66 to EN 60529 is only achieved if certified cable entries are used that are suitable for the application and correctly installed. Unused apertures shall be closed with suitable blanking elements. When installation is complete, reconnect each labeled wire to the corresponding terminal position on the junction box terminal block. Make sure to connect each wire pair's shield. Note: incorrect connection will cause the meter to malfunction.

Note: Numeric code in junction box label matches wire labels.

Fig. 27 Loop power volumetric flowmeter junction box sensor connections

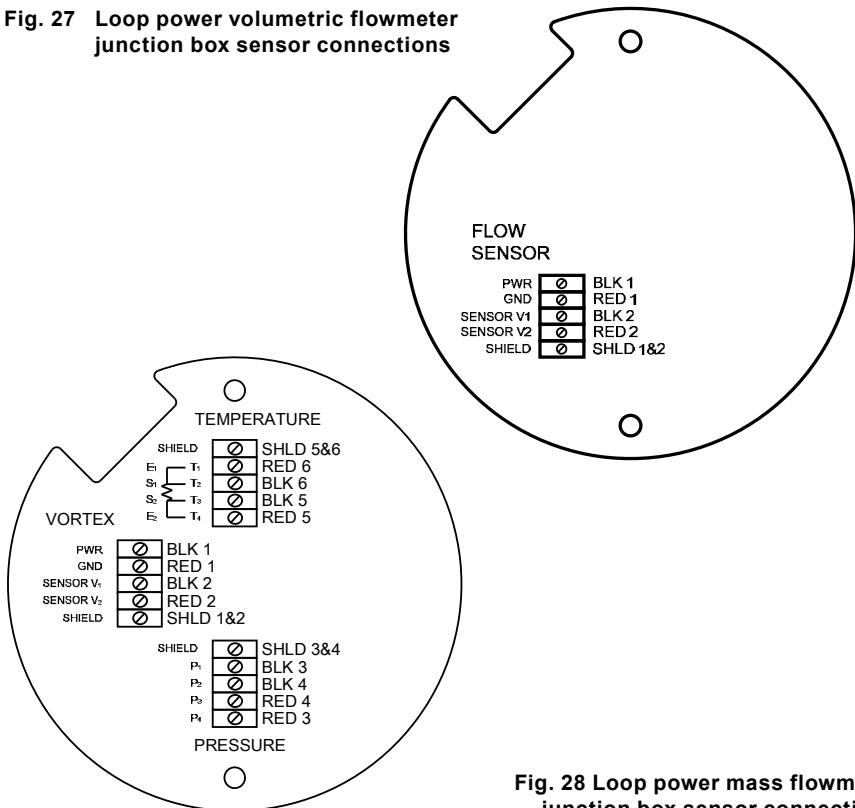

Fig. 28 Loop power mass flowmeter junction box sensor connections

3.24 High power flowmeter wiring connections



Warning!

To avoid potential electric shock, follow National Electric Code safety practices or your local code when wiring this unit to a power source and to peripheral devices.

Failure to do so could result in injury or death. All ac power connections must be in accordance with published CE directives.

All wiring procedures must be performed with the power off.

The NEMA 4X enclosure contains an integral wiring compartment with one dual strip terminal block (located in the smaller end of the enclosure).

Two 3/4" female NPT conduit entries are available for separate power and signal wiring. For all hazardous area installations, make sure to use an agency-approved fitting at each conduit entry. The cable entry device shall be of a certified flameproof type, suitable for the conditions of use and correctly installed. The degree of protection of at least IP66 to EN 60529 is only achieved if certified cable entries are used that are suitable for the application and correctly installed. Unused apertures shall be closed with suitable blanking elements. If conduit seals are used, they must be installed within 457 mm (18") of the enclosure.

3.25 Input power connections



Caution!

The ac wire insulation temperature rating must meet or exceed 85 °C (185 °F).

To access the wiring terminal blocks, locate and loosen the small set screw which locks the small enclosure cover in place. Unscrew the cover to expose the terminal block.

3.25.1 ac power wiring

The ac power wire size must be 20 to 10 AWG with the wire stripped 7 mm (0.25"). The wire insulation temperature must meet or exceed 85 °C (185 °F). Connect 100 to 240 VAC (5 W maximum) to the Hot and Neutral terminals on the terminal block. Connect the ground wire to the safety ground lug (⊕). Torque all connections to 0.5 to 0.6 N-m (4.43 to 5.31 in-lbs). Use a separate conduit entry for signal lines to reduce the possibility of ac noise interference.

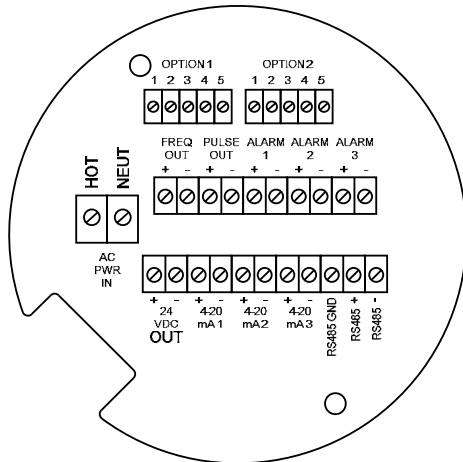

Fig. 29 ac wiring terminals

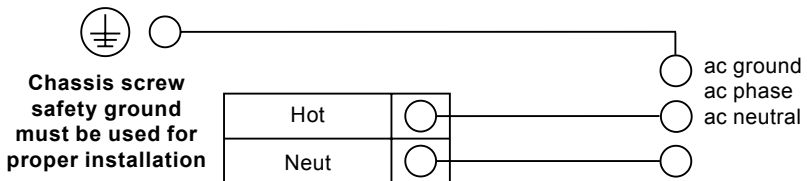

Fig. 30 ac power connections

3.25.2 dc power wiring



Caution!

The dc wire insulation temperature rating must meet or exceed 85 °C (185 °F).

The dc power wire size must be 20 to 10 AWG with the wire stripped 7 mm (0.25"). Connect 18 to 36 Vdc (300 mA, 9 W maximum) to the +dc Pwr and -dc Pwr terminals on the terminal block. Torque all connections to 0.5 to 0.6 N-m (4.43 to 5.31 in-lbs).

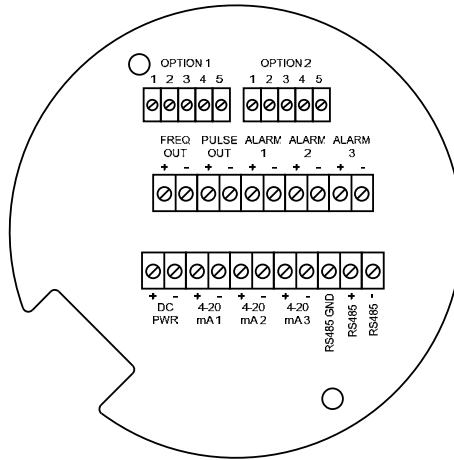

Fig. 32 dc wiring terminals

18 to 36 Vdc @ 25 mA max.

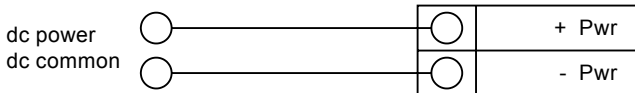

Fig. 33 dc Power Connections

3.26 4-20 mA output connections

The standard Flowmeter has a single 4-20 mA loop. Two additional loops are available on the optional communication board. The 4-20 mA loop current is controlled by the meter electronics. The electronics must be wired in series with the sense resistor or current meter. The current control electronics require 12 volts at the input terminals to operate correctly.

The maximum loop resistance (load) for the current loop output is dependent upon the supply voltage and is given in Figure 34. The 4-20 mA loop is optically isolated from the flowmeter electronics.

Rload is the total resistance in the loop, including the wiring resistance ($R_{load} = R_{wire} + R_{sense}$). To calculate R_{max} , the maximum R_{load} for the loop, subtract the minimum terminal voltage from the supply voltage and divide by the maximum loop current, 20 mA. Thus:

$$\text{The maximum resistance } R_{load} = R_{max} = (V_{supply} - 12V) / 0.020 \text{ A}$$

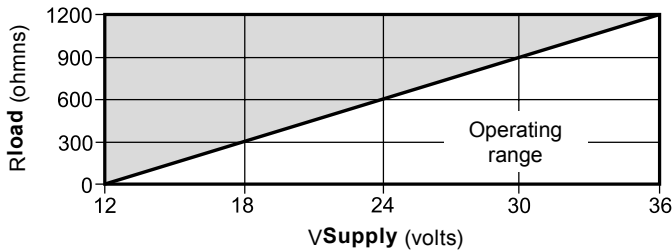

Fig. 34 Load resistance versus Input voltage

ac and dc powered flowmeters

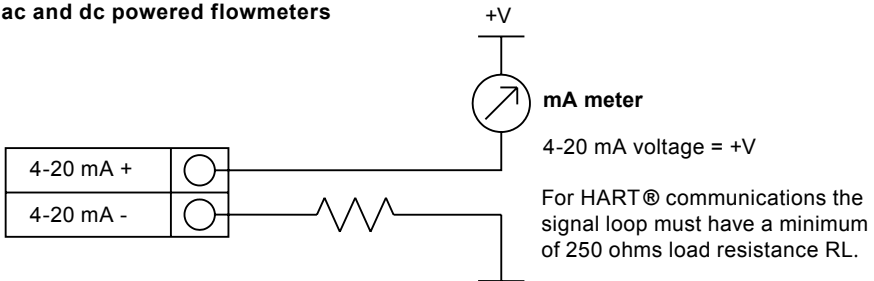

Fig. 35 Isolated 4 - 20 mA output with external power supply

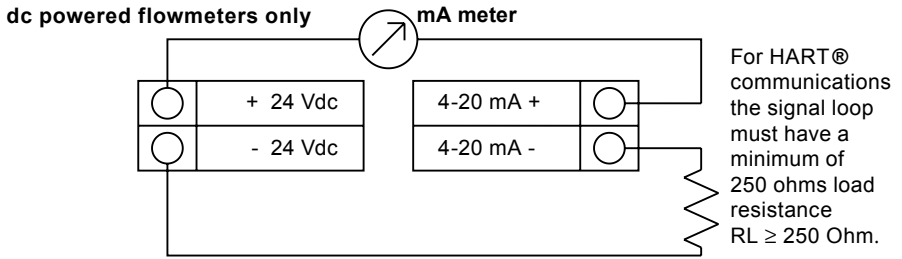

Fig. 36 Non-isolated 4-20 mA output using flowmeter input power supply

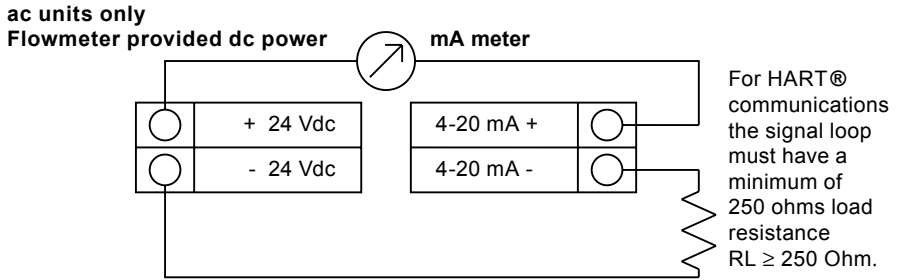

Fig. 37 Isolated 4-20 mA output using meter provided power supply

3.27 Frequency output connections

The frequency output is used for a remote counter. It can be scaled to output a 1 to 10 kHz signal proportional to mass or volume flow, temperature, pressure or density.

The frequency output requires a separate 5 to 36 Vdc power supply; however, there are current and power specifications that must be observed.

The output can conduct a current up to 40 mA and can dissipate up to 200 mW. The output is isolated from the meter electronics and power supply.

There are three connection options for the frequency output : the first with a separate power supply (Figure 38), the second using the flowmeter power supply (Figure 39)(dc powered units only), and the third using the internal 24 Vdc power supply (Figure 40)(ac powered units only). Use the first option with a separate power supply (5 to 36 Vdc) if a specific voltage is needed for the frequency output. Use the second configuration if the voltage at the flowmeter power supply is an acceptable driver voltage for the load connected. (Take into account that the current used by the frequency load comes from the meters power supply). Use the third configuration if you have an ac powered unit only. In any case, the voltage of the frequency output is the same as the voltage supplied to the circuit.

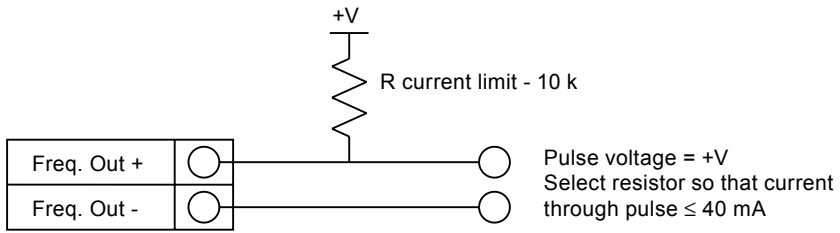

Fig. 38 Isolated frequency output using external power supply

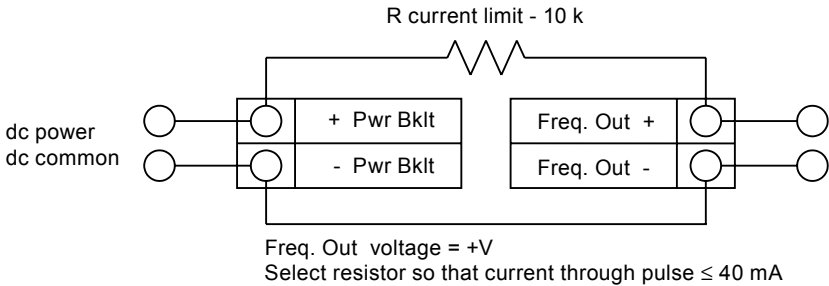

Fig. 39 Non-Isolated frequency output using input power supply

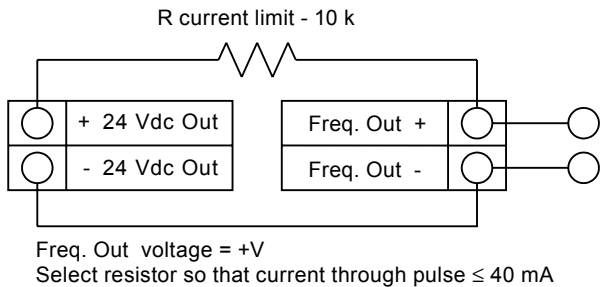

Fig. 40 Isolated frequency output using meter provided power supply

3.28 Pulse output connections

The pulse output is used for a remote counter. When the preset volume or mass (defined in the totalizer settings, see Section 4) has passed the meter, the output provides a 50 millisecond square pulse.

The pulse output optical relay is a normally-open single-pole relay. The relay has a nominal 200 volt/160 ohm rating. This means that it has a nominal on-resistance of 160 ohms, and the largest voltage that it can withstand across the output terminals is 200 volts. However, there are current and power specifications that must be observed. The relay can conduct a current up to 40 mA and can dissipate up to 320 mW. The relay output is isolated from the meter electronics and power supply.

There are three connection options for the pulse output the first with a separate power supply (Figure 41), the second using the flowmeter power supply (Figure 42)(dc powered units only), and the third using the internal 24 Vdc power supply (Figure 43)(ac powered units only). Use the first option with a separate power supply (5 to 36 Vdc) if a specific voltage is needed for the pulse output. Use the second configuration if the voltage at

the flowmeter power supply is an acceptable driver voltage for the load connected. (Take into account that the current used by the pulse load comes from the meter's power supply). Use the third configuration if you have an ac powered unit only. In any case, the voltage of the pulse output is the same as the voltage supplied to the circuit.

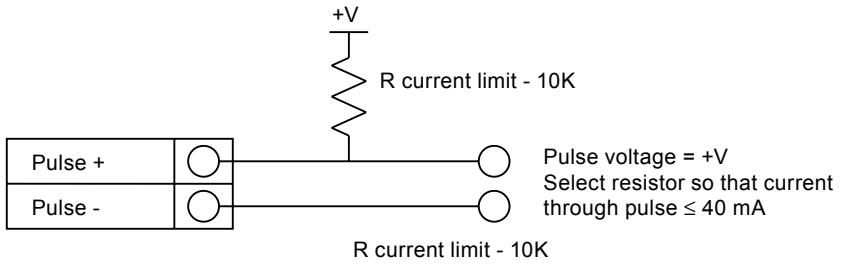

Fig. 41 Isolated pulse output with external power supply

dc powered flowmeters

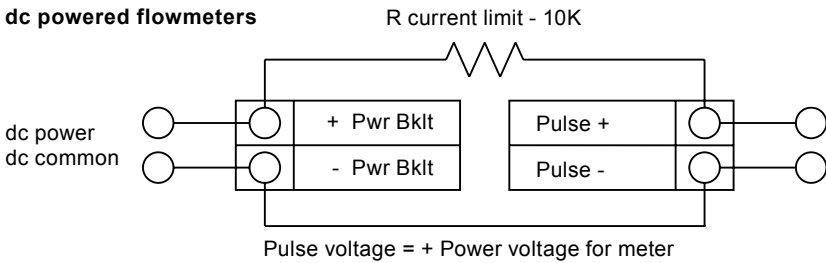

Fig. 42 Non-isolated pulse output using input power supply

ac units only

Flowmeter provided dc power

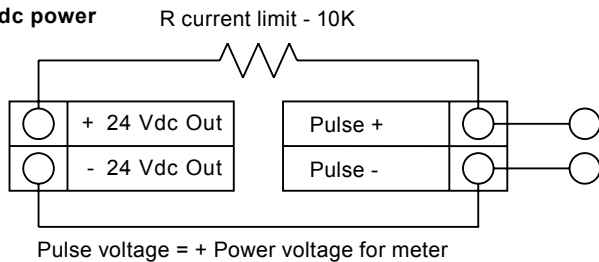

Fig. 43 Isolated pulse output using flowmeter provided power supply

3.29 Alarm output connections

One alarm output (Alarm 1) is included on the standard flowmeter. Two or more alarms (Alarm 2 and Alarm 3) are included on the optional communication board. The alarm output optical relays are normally-open single-pole relays. The relays have a nominal 200 volt/160 ohm rating. This means that each relay has a nominal on-resistance of 160 ohms and the largest voltage that it can withstand across the output terminals is 200 volts. However, there are current and power specifications that must be observed. The relay can conduct a current up to 40 mA and can dissipate up to 320 mW. The relay output is isolated from the meter electronics and power supply. When the alarm relay is closed, the current draw will be constant. Make sure to size **Rload** appropriately.

There are three connection options for the alarm output the first with a separate power supply (Figure 44), the second using the flowmeter power supply (Figure 45) (dc powered units only) and the third with the meter provided power supply (Figure 46) (ac powered units only). Use the first option with a separate power supply (5 to 36 Vdc) if a specific voltage is needed for the alarm output. Use the second configuration if the voltage at the flowmeter power supply is an acceptable driver voltage for the load connected. (Take into account that the current used by the alarm load comes from the meter's power supply). Use the third if you have an ac powered unit only. In any case, the voltage of the alarm output is the same as the voltage supplied to the circuit.

The alarm output is used for transmitting high or low process conditions as defined in the alarm settings (see Section 4).

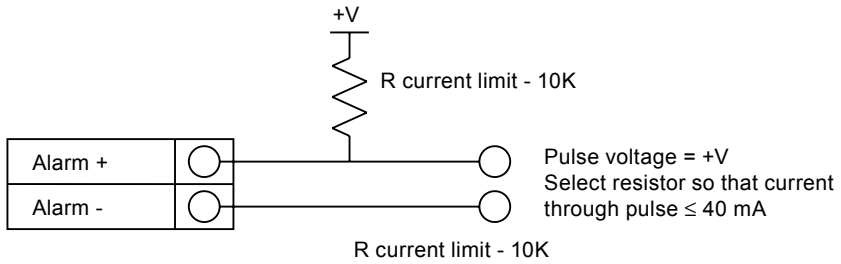

Fig. 44 Isolated pulse output with external power supply

dc powered flowmeters

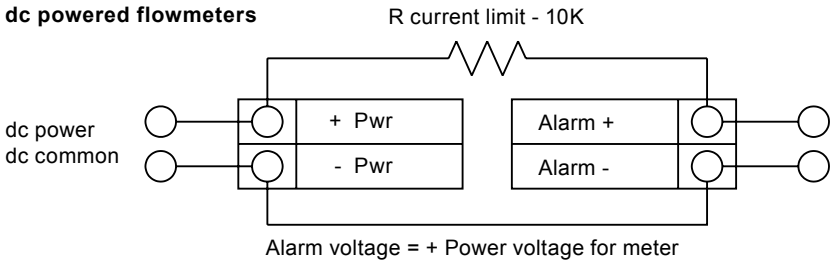

Fig. 45 Non-isolated pulse output using input power supply

ac units only

Flowmeter provided dc power

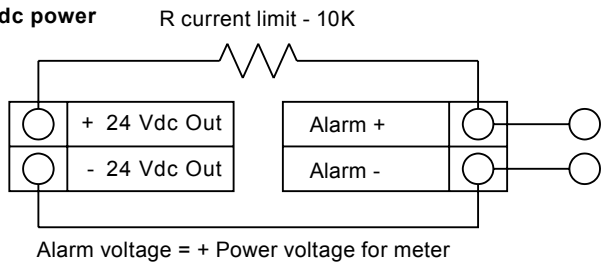

Fig. 46 Isolated pulse output using flowmeter provided power supply

3.30 Remote electronics wiring

The remote electronics enclosure should be mounted in a convenient, easy to reach location. For hazardous location installations, make sure to observe agency requirements for installation. Allow some slack in the interface cable between the junction box and the remote electronics enclosure. To prevent damage to the wiring connections, do not put stress on the terminations at any time.

The meter is shipped with temporary strain relief glands at each end of the cable. Disconnect the cable from the meter's terminal block inside the junction box not at the remote electronics enclosure. Remove both glands and install appropriate conduit entry glands and conduit. The cable entry device shall be of a certified flameproof type, suitable for the conditions of use and correctly installed. The degree of protection of at least IP66 to EN 60529 is only achieved if certified cable entries are used that are suitable for the application and correctly installed. Unused apertures shall be closed with suitable blanking elements. When installation is complete, reconnect each labeled wire to the corresponding terminal position on the junction box terminal block. Make sure to connect each wire pair's shield. Note: incorrect connection will cause the meter to malfunction.

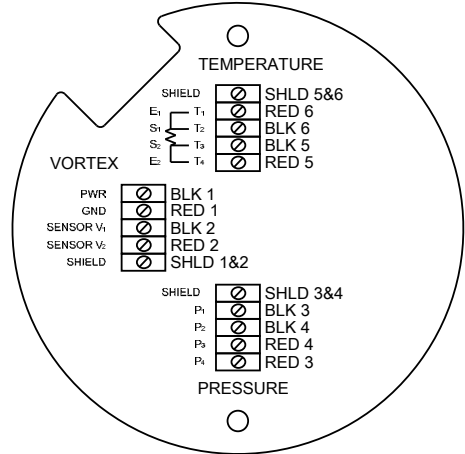

Fig. 47 High Power flowmeter junction box sensor connections

Note: Numeric code in junction box label matches wire labels.

3.31 Optional input electronics wiring

The meter has two optional input wiring terminals. These can be used to input a Remote or Second RTD input in the case of an Energy Monitoring meter, for the input of a Remote Pressure Transducer, to pass a Contact Closure or for a Remote Density measurement to name a few. In any case, the wiring diagram will be included with the meter if any of the options are specified. Otherwise, the optional terminal blocks will be left blank and non functional.

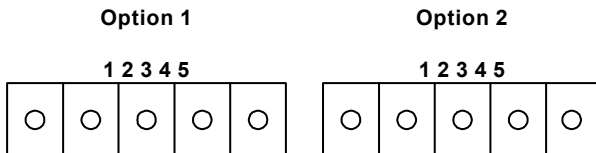

Fig. 48

3.32 Optional energy EM RTD input wiring

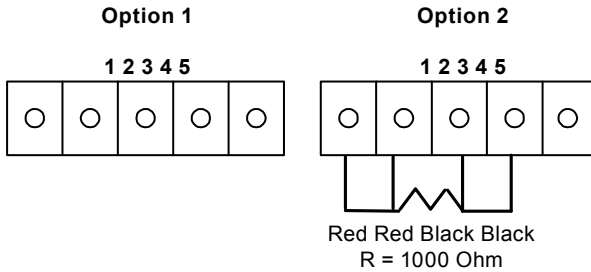

Fig. 49 Optional energy EM RTD input wiring

The recommended customer supplied second RTD is a Class A 1000 ohm 4-wire platinum RTD. If a second RTD is not being used, then the factory supplied 1000 ohm resistor needs to be installed in its place.

3.33 Optional external 4-20 mA input wiring

The meter is set to have Option 1 used for the external input. Programming menus that pertain to the optional 4-20 mA input are located in the Hidden Diagnostics Menu in Section 6.

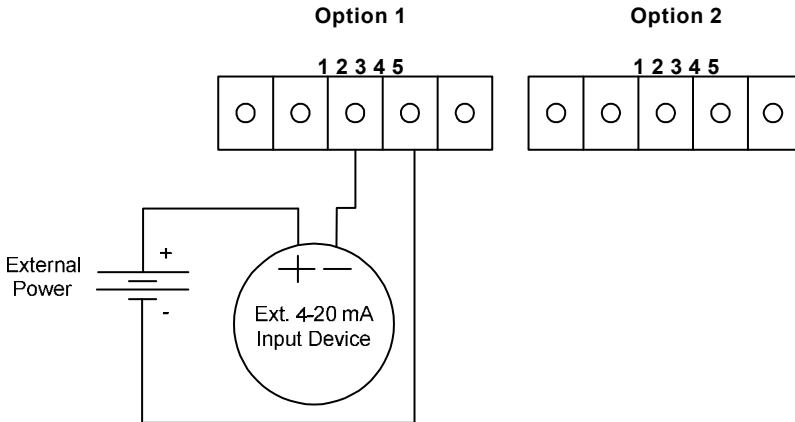

Fig. 50 External 4-20 mA input wiring - External power supply

Follow the above diagram to wire the external 4-20 mA input into the flowmeter using an external power supply.

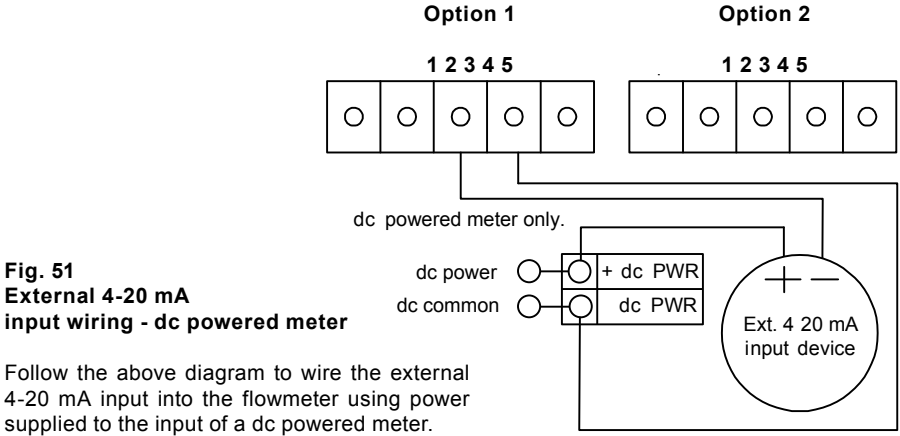

Fig. 51
External 4-20 mA
input wiring - dc powered meter

Follow the above diagram to wire the external 4-20 mA input into the flowmeter using power supplied to the input of a dc powered meter.

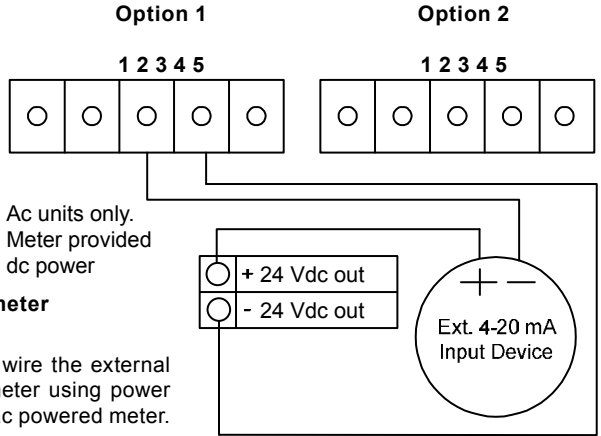

Fig. 52
External 4-20 mA
input wiring - ac powered meter

Follow the above diagram to wire the external 4-20 mA input into the flowmeter using power from the 24 Vdc output of an ac powered meter.

3.34 Optional external contact closure input wiring

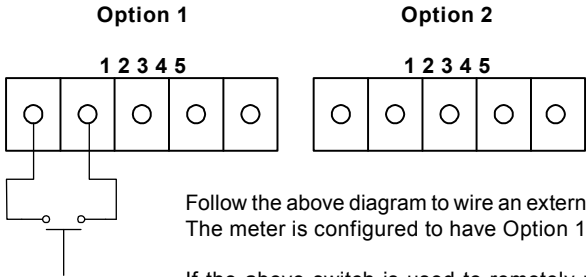

Fig. 53
Optional external contact closure input wiring

Follow the above diagram to wire an external switch input into the flowmeter. The meter is configured to have Option 1 used for the external input.

If the above switch is used to remotely reset the totalizer a pushbutton switch with a momentary contact closure is recommended.

4. Operating instructions

After installing the Vortex Flowmeter, you are ready to begin operation. The sections in this chapter explain the display/keypad commands, meter start-up and programming. The meter is ready to operate at start up without any special programming.

To enter parameters and system settings unique to your operation, see the following pages for instructions on using the setup menus.

4.1 Flowmeter display / keypad

The flowmeter's digital electronics allow you to set, adjust and monitor system parameters and performance. A full range of commands are available through the display/keypad. The LCD display gives 2 x 16 characters for flow monitoring and programming.

The six push-buttons can be operated with the enclosure cover removed. Or, the explosion-proof cover can remain in place and the keypad operated with a hand-held magnet positioned at the side of the enclosure as shown in the illustration at the left.

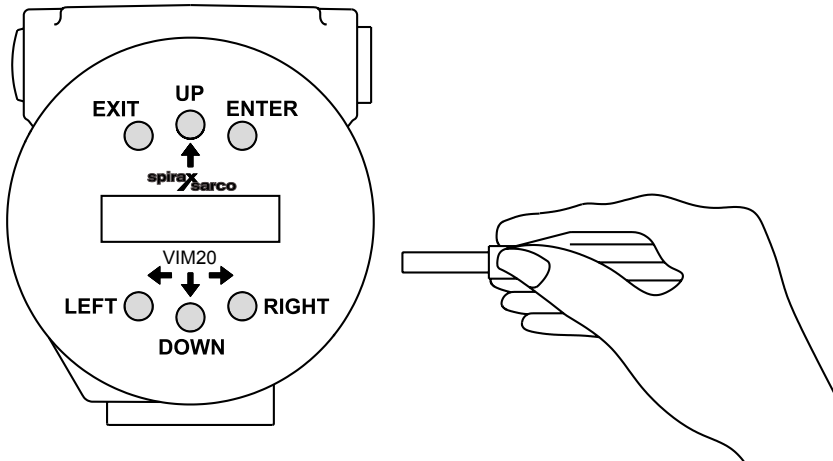

Fig. 54 Display / keypad commands

From the Run Mode, the ENTER key allows access to the Setup Menu (through a password screen). Within the Setup Menu, pressing ENTER activates the current field.

To set new parameters, press the ENTER key until an underline cursor appears.

Use ⬆ ⬇ ⬅ ➡ the keys to select new parameters.

Press ENTER to continue. (If change is not allowed, ENTER has no effect.) All outputs are disabled when using the Setup Menu.

The EXIT key is active within the Setup Menu.

When using a Setup Menu, EXIT returns you to the Run Mode. If you are changing a parameter and make a mistake, EXIT allows you to start over.

The ⬆ ⬇ ⬅ ➡ keys advance through each screen of the current menu. When changing a system parameter, all ⬆ ⬇ ⬅ ➡ keys are available to enter new parameters.

4.2 Start-up



Note

Starting the flowmeter or pressing EXIT will always display the Run Mode screens.

To begin flowmeter operation:

1. Verify the flowmeter is installed and wired as described in Section 3.
2. Apply power to the meter. At start up, the unit runs a series of selftests that check the RAM, ROM, EPROM and all flow sensing components.
After completing the self-test sequence, the Run Mode screens appear.
3. The Run Mode displays flow information as determined by system settings. Some screens depicted on the next page may not be displayed based on these settings. Press the arrow keys to view the Run Mode screens.
4. Press the ENTER key from any Run Mode screen to access the Setup Menus. Use the Setup Menus to configure the meter's multiparameter features to fit your application.

Run mode screens

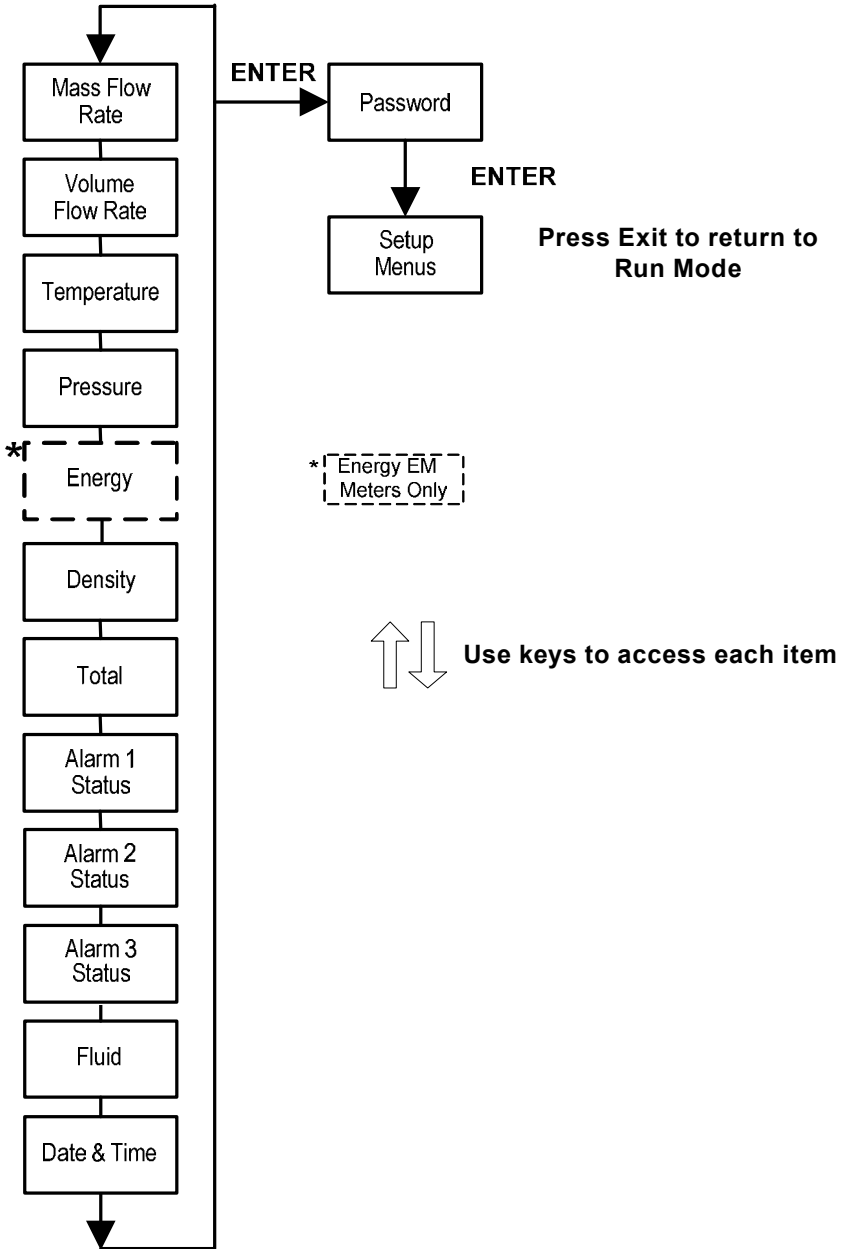

4.3 Using the set-up menus

Run mode screens

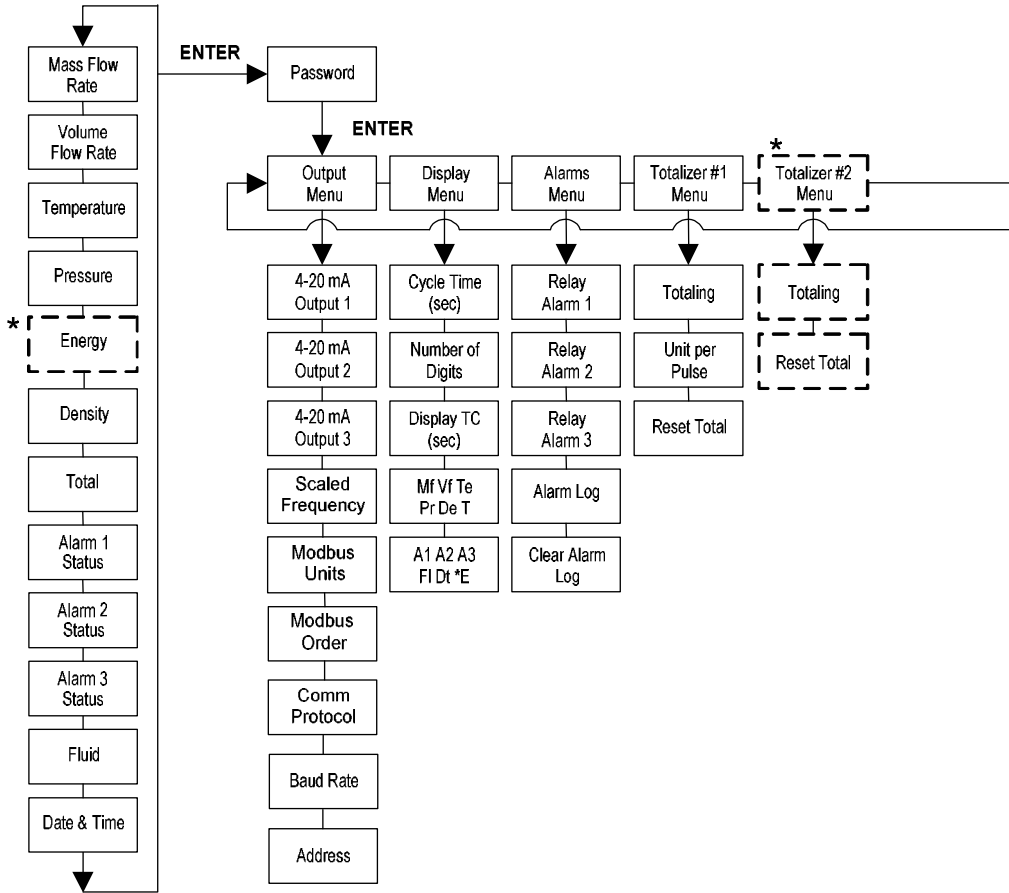

Setup menus

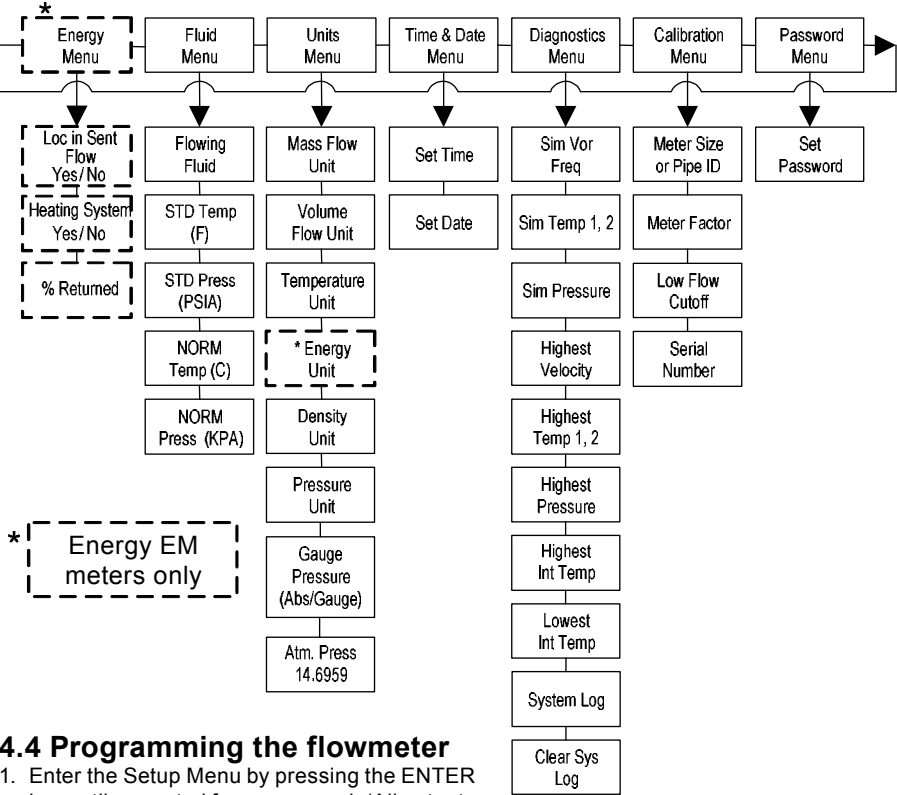

4.4 Programming the flowmeter

1. Enter the Setup Menu by pressing the ENTER key until prompted for a password. (All outputs are disabled while using the Setup Menus.)
2. Use the \uparrow \downarrow \leftarrow \rightarrow keys to select the password characters (1234 is the factory-set password). When the password is correctly displayed, press ENTER to continue.
3. Use the Setup Menus described on the following pages to customize the multiparameter features of your Flowmeter. (The entire lower display line is available for entering parameters.) Some items depicted in the graphic on the preceding page may not be displayed based on flowmeter configuration settings
4. To activate a parameter, press ENTER. Use the \uparrow \downarrow \leftarrow \rightarrow keys to make selections. Press ENTER to continue. Press EXIT to save or discard changes and return to Run Mode.
5. Program the UNITS menu first because later menus will be based on the units selected.

4.5 Output menu

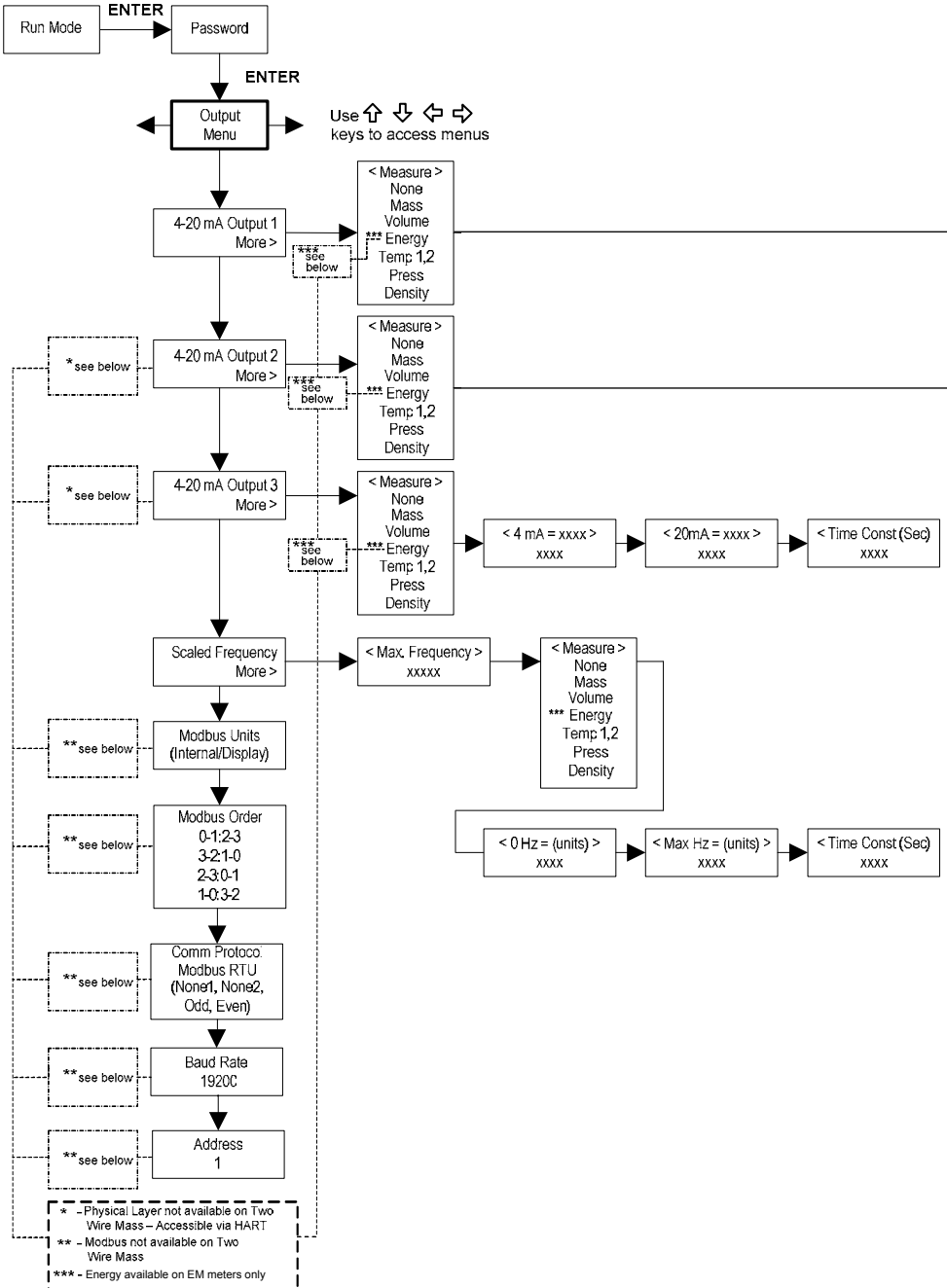

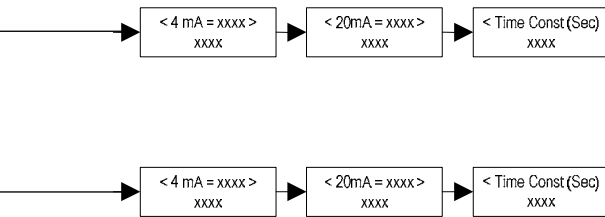

Example for setting an output

The following shows how to set Output 1 to measure mass flow with 4 mA = 0 kg/hr (0 lb/hr) and 20 mA = 45.35 kg/hr (100 lb/hr) with a time constant of 5 seconds. (All outputs are disabled while using the Setup Menus.)

First, set the desired units of measurement:

1. Use $\leftarrow \rightarrow$ keys to move to the Units Menu.
2. Press \downarrow key until Mass Flow Unit appears. Press ENTER.
3. Press \downarrow key until lb appears in the numerator. Press \Rightarrow key to move the underline cursor to the denominator. Press the key until hr appears in the denominator. Press ENTER to select.
4. Press \uparrow key until Units Menu appears.

Second, set the analog output:

1. Use $\uparrow \downarrow \leftarrow \rightarrow$ keys to move to the Output Menu.
2. Press the \downarrow key until 4-20 mA Output 1 appears.
3. Press \Rightarrow key to access Measure selections. Press ENTER and press the \downarrow key to select Mass. Press ENTER.
4. Press \Rightarrow key to set the 4 mA point in the units you have selected for mass of lb/hr. Press ENTER and use $\uparrow \downarrow \leftarrow \rightarrow$ keys to set 0 or 0.0. Press ENTER.
5. Press \Rightarrow key to set the 20 mA point. Press ENTER and use $\uparrow \downarrow \leftarrow \rightarrow$ keys to set 100 or 100.0. Press ENTER.
6. Press \Rightarrow key to select the Time Constant. Press ENTER and use $\uparrow \downarrow \leftarrow \rightarrow$ keys to select 5. Press ENTER.
7. Press the EXIT key and answer YES to permanently save your changes.

4.6 Display menu

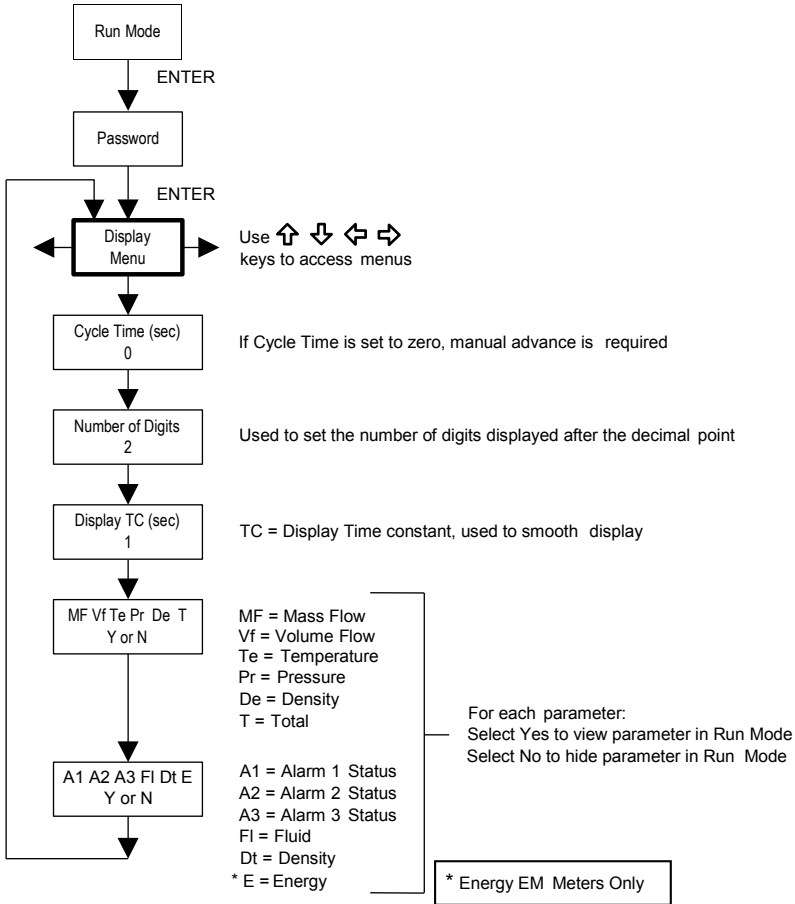

Use the Display Menu to set the cycle time for automatic screen sequencing used in the Run Mode, change the precision of displayed values, smooth the values or enable or disable each item displayed in the Run Mode screens.

Example for changing a run mode display item

The following shows how to remove the temperature screen from the Run Mode screens.

Note: all outputs

are disabled while using the Setup Menus.

1. Use ⇐⇒ keys to move to the Display Menu.
2. Press ↓ key until Mf Vf Pr Te De T appears.
3. Press ENTER to select. Press ⇒ key until the cursor is positioned below Te.
4. Press ↓ key until N appears. Press ENTER to select.
5. Press EXIT and then ENTER to save changes and return to the Run Mode.

4.7 Alarms menu

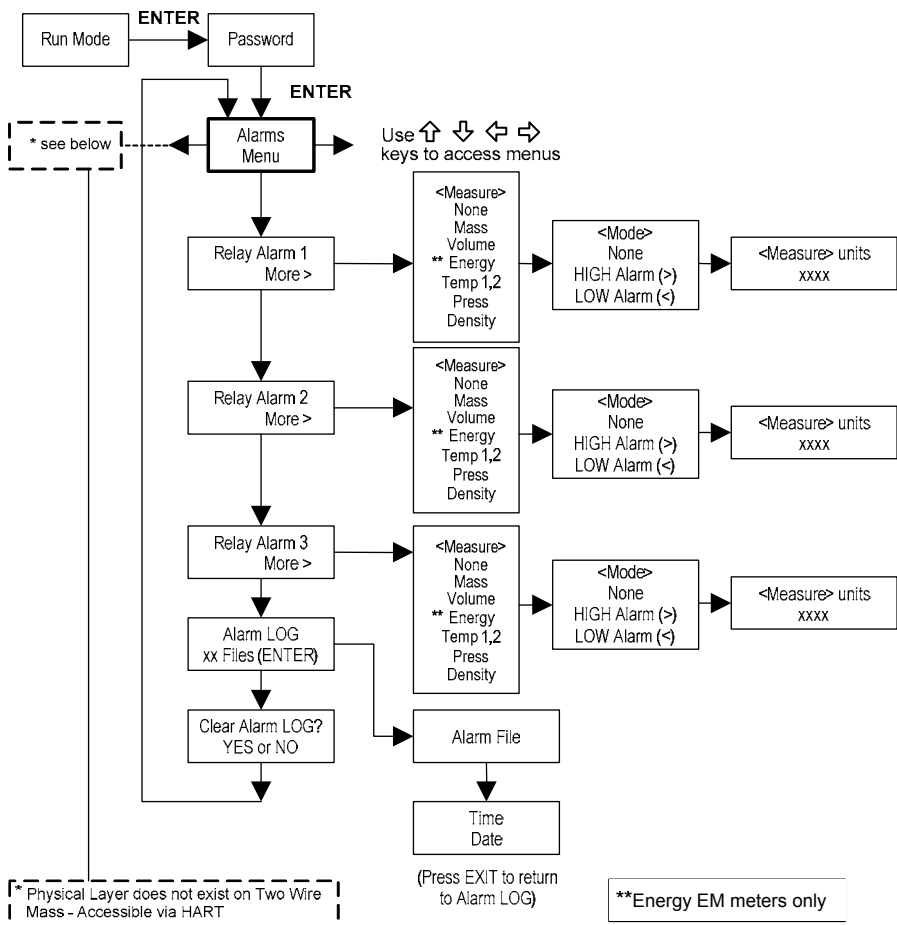

Example for setting an alarm

The following shows how to set Relay Alarm 1 to activate if the mass flowrate is greater than 45.35 kg/hr (100 lb/hr). You can check the alarm configuration in the Run Mode by pressing the keys until Alarm [1] appears. The lower line displays the mass flowrate at which the alarm activates. Note: all outputs are disabled while using the Setup Menus.

First, set the desired units of measurement:

1. Use ⇐⇒ keys to move to the Units Menu.
2. Press ↓ key until Mass Flow Unit appears. Press ENTER.
3. Press ↓ key until lb appears in the numerator. Press ⇒ key to move the underline cursor to the denominator. Press the ↓ key until hr appears in the denominator. Press ENTER to select.
4. Press ↑ key until Units Menu appears.

Second, set the alarm:

1. Use ⇐⇒ keys to move to the Alarms Menu.
2. Press the ↓ key until Relay Alarm 1 appears.
3. Press ⇒ key to access Measure selections. Press ENTER and use the key to select Mass. Press ENTER.
4. Press ⇒ key to select the alarm Mode. Press ENTER and use key to select HIGH Alarm. Press ENTER.
5. Press ⇒ key to select the value that must be exceeded before the alarm activates. Press ENTER and use ↑↓⇐⇒ keys to set 100 or 100.0. Press ENTER.
6. Press the EXIT key to save your changes. (Alarm changes are always permanently saved.) (Up to three relay alarm outputs are available depending on meter configuration.)

4.8 Totalizer #1 menu

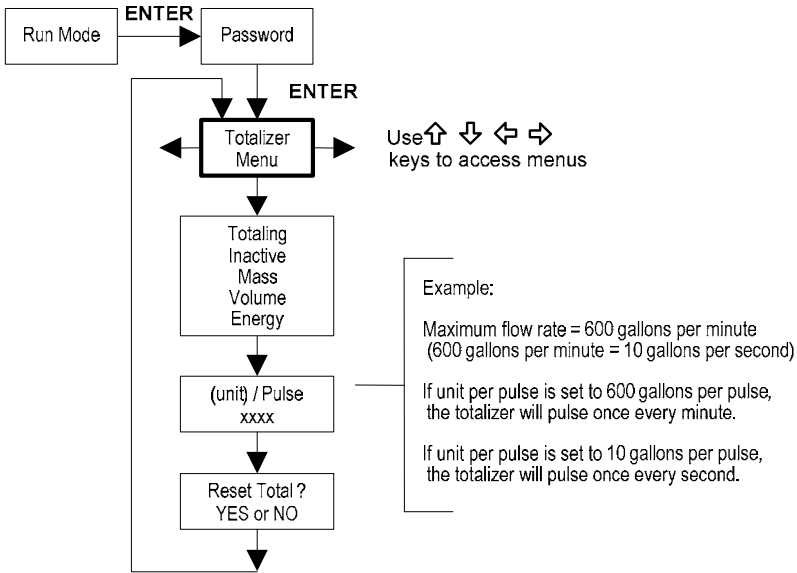

Use the Totalizer Menu to configure and monitor the totalizer. The totalizer output is a 50 millisecond (.05 second) positive pulse (relay closed for 50 milliseconds). The totalizer cannot operate faster than one pulse every 100 millisecond (.1 second). A good rule to follow is to set the unit per pulse value equal to the maximum flow in the same units per second. This will limit the pulse to no faster than one pulse every second.

Example for setting an alarm

The following shows how to set the totalizer to track mass flow in kg/sec. (All outputs are disabled while using the Setup Menus.)

First, set the desired units of measurement:

1. Use $\leftarrow \rightarrow$ keys to move to the Units Menu (see to Section 4).
2. Press \downarrow key until Mass Flow Unit appears. Press ENTER.
3. Press \downarrow key until kg appears in the numerator. Press \downarrow key to move the underline cursor to the denominator. Press the \downarrow key until sec appears in the denominator. Press ENTER to select.
4. Press \uparrow key until Units Menu appears.

Second, set the pulse output:

1. Use $\leftarrow \rightarrow$ keys to move to the Totalizer Menu.
2. Press the \downarrow key until Totaling appears.
3. Press ENTER and press the \downarrow key to select Mass. Press ENTER.
4. Press \downarrow key to set the pulse output in the units you have selected for mass flow of kg/sec. Press ENTER and use $\uparrow \downarrow \leftarrow \rightarrow$ keys to set the pulse value equal to the maximum flow in the same units per second. Press ENTER.
5. To reset the totalizer, press \downarrow key until Reset Total? appears. Press ENTER and the key to reset the totalizer if desired. Press ENTER.
6. Press the EXIT key and answer YES to permanently save your changes.

4.9 Totalizer #2 menu

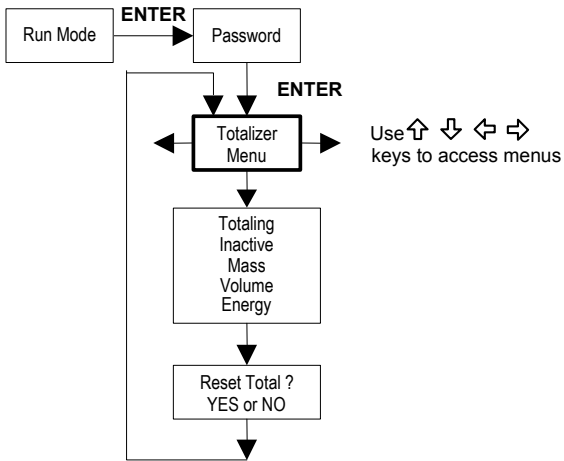

Use the Totalizer #2 to Monitor Flow or Energy. Note that Totalizer #2 does not operate a relay, it is for monitoring only.

4.10 Energy menu - For EM energy meters only

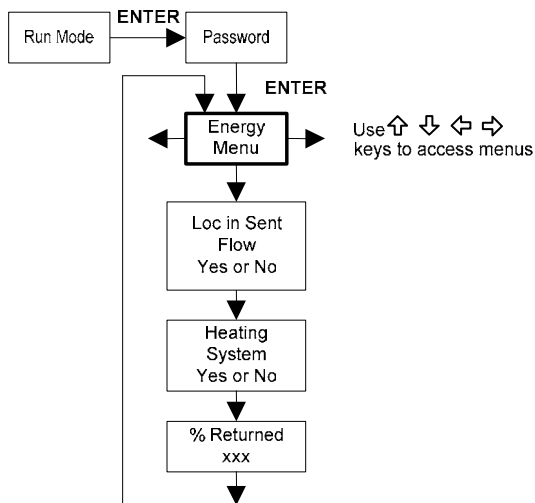

Configuration:

There are several possibilities regarding the measurement of water or steam energy given the location of the meter and the use of a second RTD. The table below summarizes the possibilities:

Fluid	Meter location	Second RTD	Measurement
Water	"Sent" Flow Line	"Return" Flow Line	Change in Energy
Water	"Return" Flow Line	"Sent" Flow Line	Change in Energy
Water	"Sent" Flow Line	None	Outgoing Energy
Steam	"Sent" Flow Line	"Return" Flow Line (condensate)	Change in Energy
Steam	"Sent" Flow Line	None	Outgoing Energy

As above, you must properly configure the meter in the Energy Menu.

1. Loc in Sent Flow? Select Yes or No based on where the meter is located. Refer to the above table
2. Heating System? Select Yes for a hot water system used for heating. Select No for a chilled water system used for cooling. Always select Yes for a steam system.
3. % Returned. Select a number between 0% and 100%. Estimate the amount of water that returns.

It is usually 100%, or can be less than 100% if historical data shows the amount of makeup water used. If a second RTD is not used, set to 0%. When 0% is selected, the energy calculation represents the outgoing energy only (no return energy is subtracted).

NOTE: the meter ships from the factory assuming 0% return and has a 1000 ohm resistor installed in the RTD #2 wiring location. This needs to be removed if the meter is to be used in a manner other than with 0% return and with the customer supplied RTD in its place.

4.11 Fluid menu

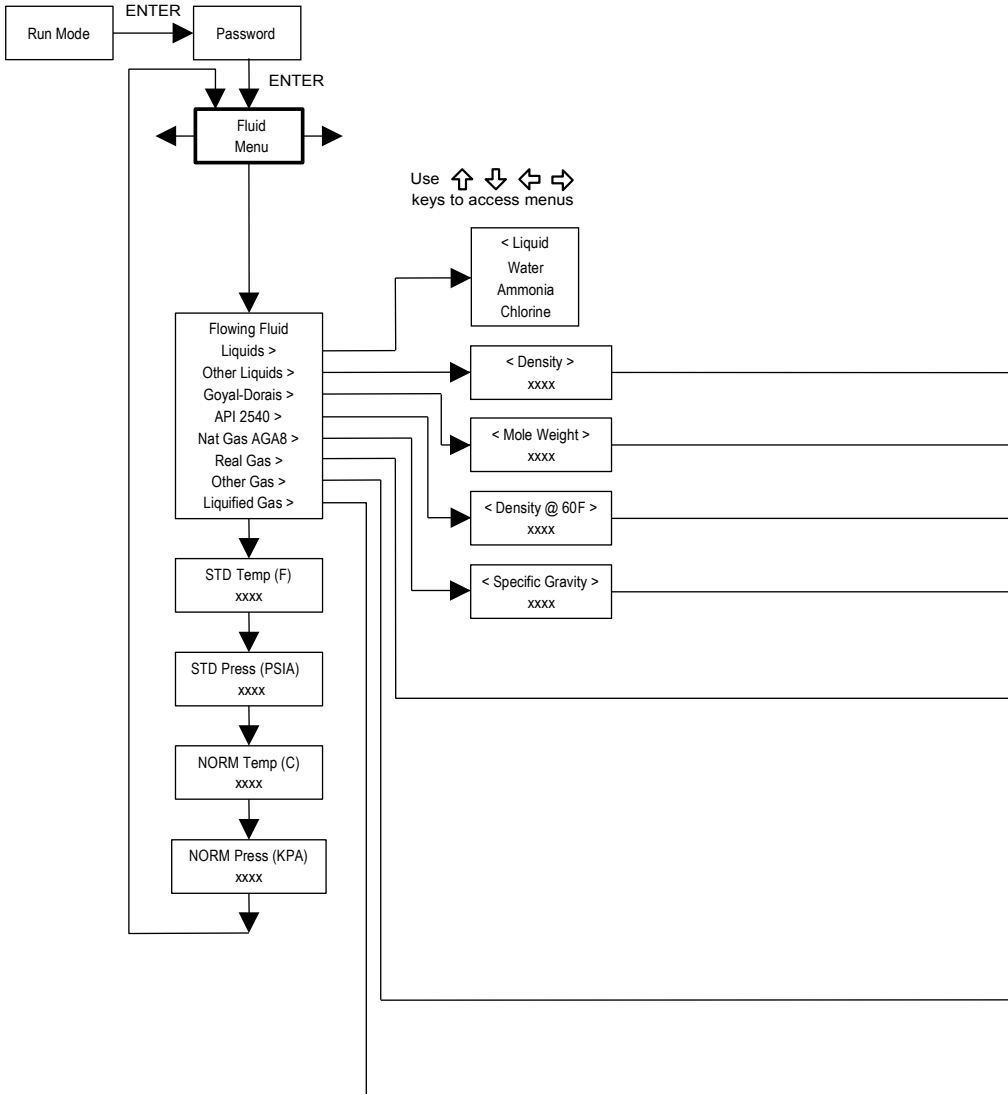

Use the Fluid Menu to configure the flowmeter for use with common gases, liquids and steam. Your flowmeter is pre-programmed at the factory for your application's process fluid.

Reference Richard W. Miller, Flow Measurement Engineering Handbook (Third Edition, 1996), and use of the Goyal-Doraiswamy equation and use of the API 2540 equation. Also, see Appendix C for Fluid Calculation equations.

The units of measurement used in the Fluid Menu are preset and are as follows:

- Mole Weight = lbm/(lbm-mol),
- CRIT PRESS = psi a,
- CRIT TEMP = °R,
- Density = Kg/m³ and
- Viscosity = cP (centipoise).

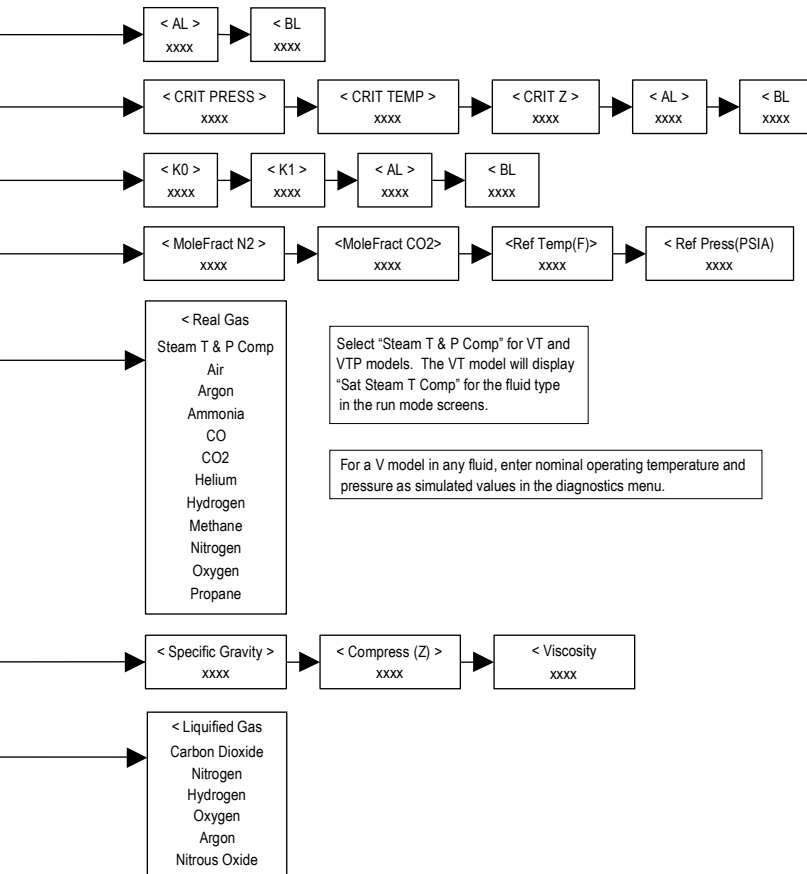

4.12 Units menu

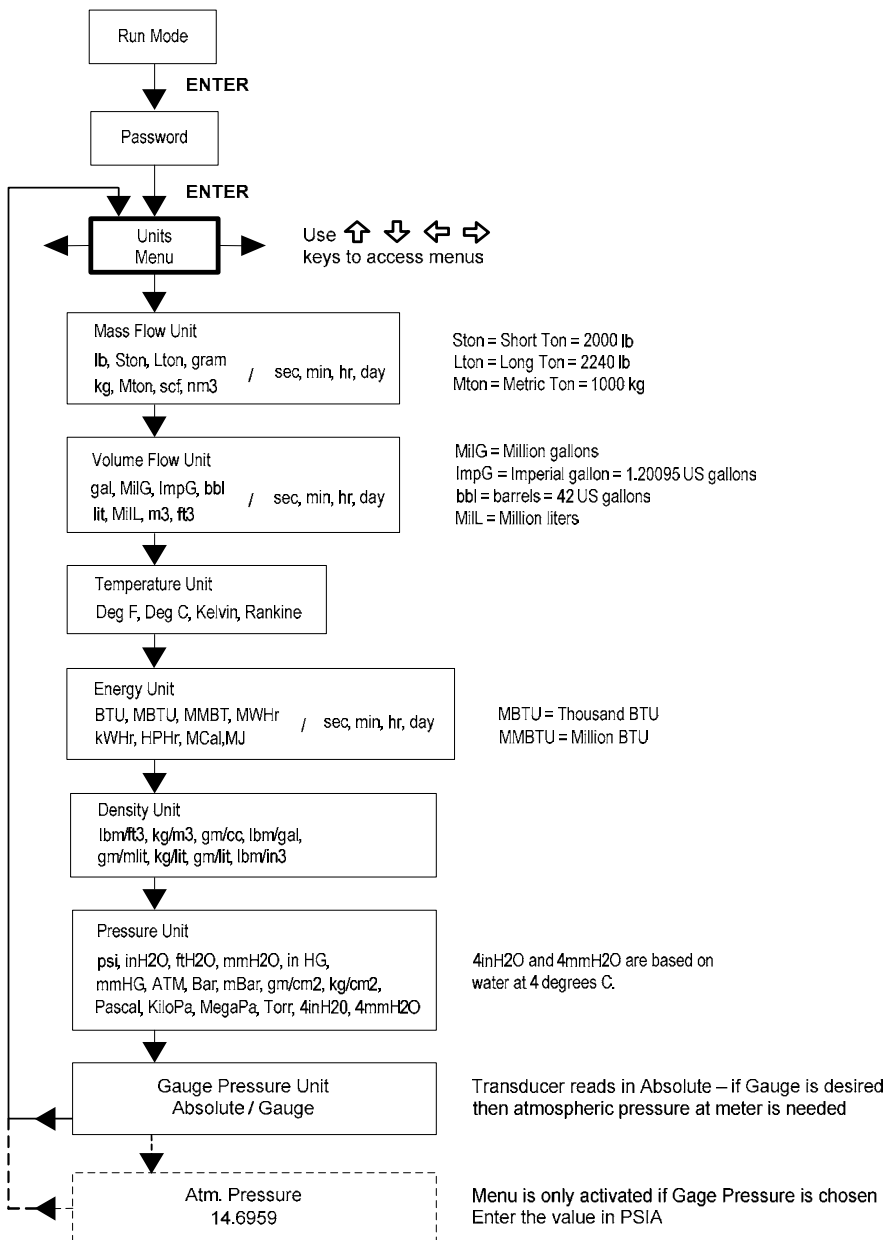

Use the Units Menu to configure the flowmeter with the desired units of measurement. (These are global settings and determine what appears on all screens.)

4.13 Time and date menu

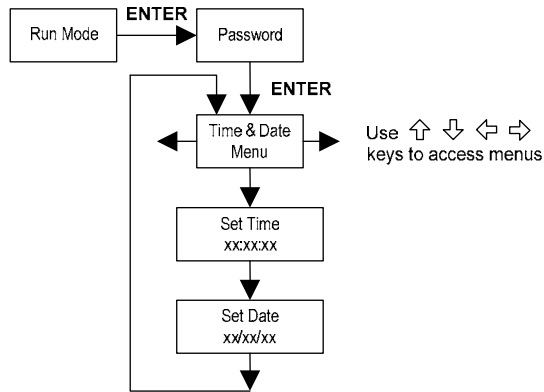

Use the Time and Date Menu to enter the correct time and date into the flowmeter's memory. The parameters are used in the Run Mode and the alarm and system log files.

Note: Time is displayed in AM/PM format, but military format is used to set the time. For example, 1:00 PM is entered as 13:00:00 in the Set Time menu.

Example for setting the time

How to set the time to 12:00:00. You can check the time in the Run Mode by pressing the keys until the Time & Date screen appears. Note: all outputs are disabled while using the Setup Menus.

1. Use keys to move to the Time and Date Menu.
2. Press key until Set Time appears. Press ENTER.
3. Press key until 1 appears. Press key to move the underline cursor to the next digit. Press the key until 2 appears. Continue sequence until all desired parameters are entered. Press ENTER to return to the Time and Date Menu.
4. Press EXIT to return to the Run Mode.

4.14 Diagnostics menu

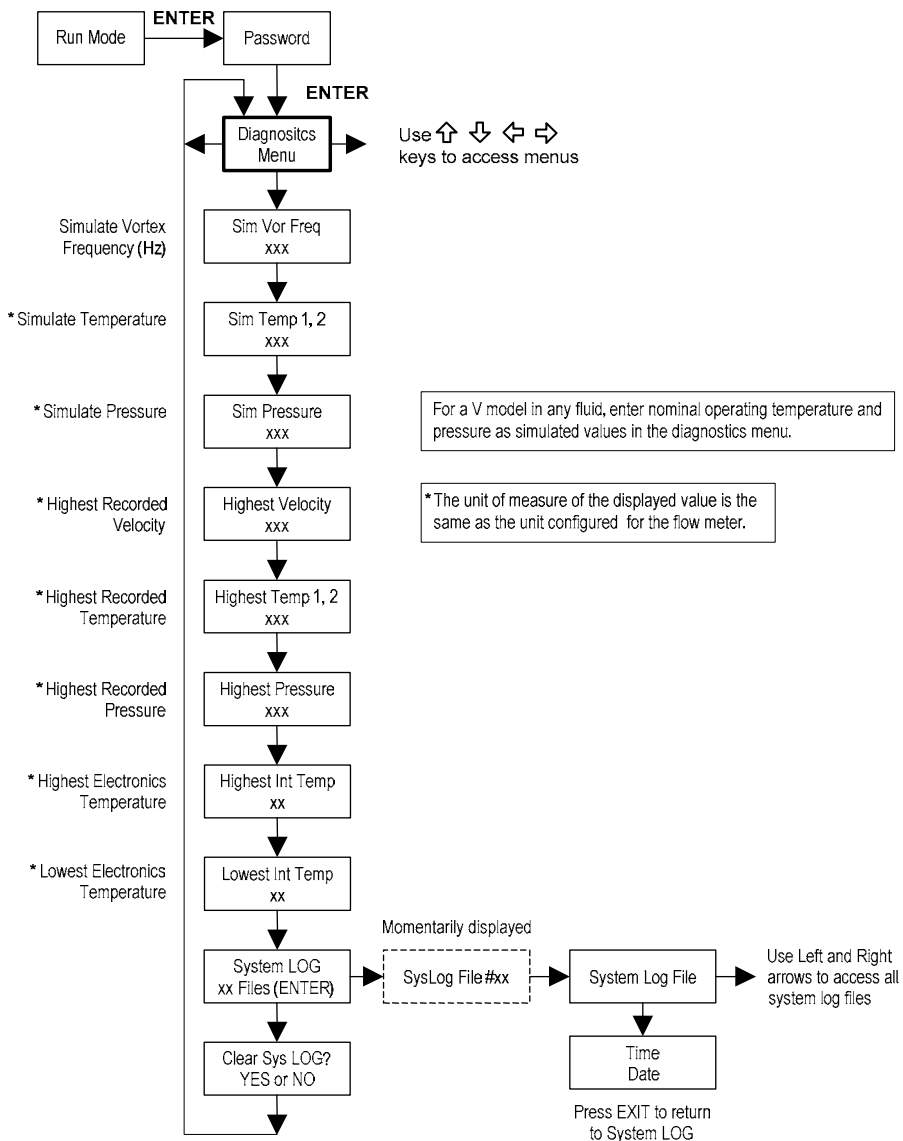

Use the Diagnostics Menu to simulate operation and review the system files. The system log files contain time/date stamped messages including: power on, power off, programming time outs, parameter faults, incorrect password entry and other various information relative to system operation and programming.

The simulated inputs are for testing the meter to verify that the programming is correct. They are also used to enter nominal operating temperature and pressure for the V only model. Simulated vortex frequency allows you to enter any value for the sensor input in Hz. The meter will calculate a flow rate based on the corresponding value and update all analog outputs (**the totalizer display and output is not affected by a simulated frequency**). The simulated pressure and temperature settings work the same way. The meter will output these new values and will use them to calculate a new density for mass flow measurement. Note: when your diagnostic work is complete, make sure to return the values to zero to allow the electronics to use the actual transducer values. For the V only model keep the temperature and pressure at nominal operating conditions.

If the meter display indicates a temperature or pressure fault, a substitute value can be entered to allow flow calculations to continue at a fixed value until the source of the fault is identified and corrected. The units of measure of the displayed values are the same as the units configured for the flowmeter.

4.15 Calibration menu

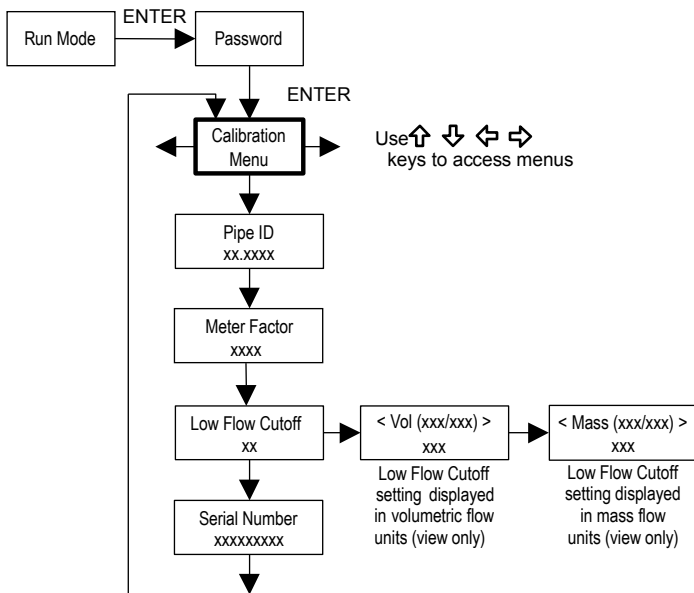

The Calibration Menu contains the calibration coefficients for the flowmeter. These values should be changed only by properly trained personnel. The Low Flow Cutoff is set at the factory.

Consult the factory for help with these settings if the meter is showing erratic flowrate.

4.16 Password menu

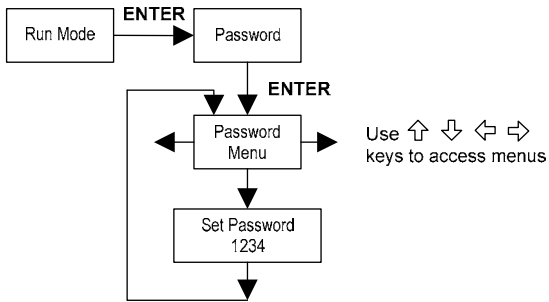

Use the Password Menu to set or change the system password. The factory-set password is 1234.

5. Serial communications

5.1 HART communications

The HART Communications Protocol (Highway Addressable Remote Transducer Protocol) is a bidirectional digital serial communications protocol. The HART signal is based on the Bell 202 standard and is superimposed on 4-20 mA Output 1. Peer-to-peer (Analogue / digital) and multi-drop (digital only) modes are supported.



Warning!

Place controls in manual mode when making configuration changes to the turbine meter.

5.2 Wiring

The diagrams below detail the proper connections required for HART communications:

5.2.1 Loop powered meter wiring

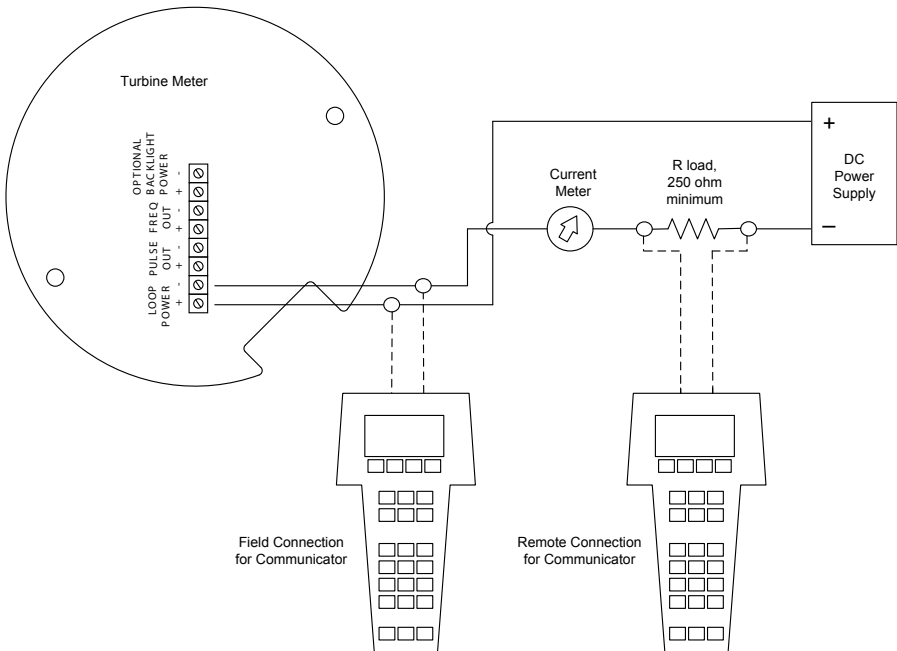
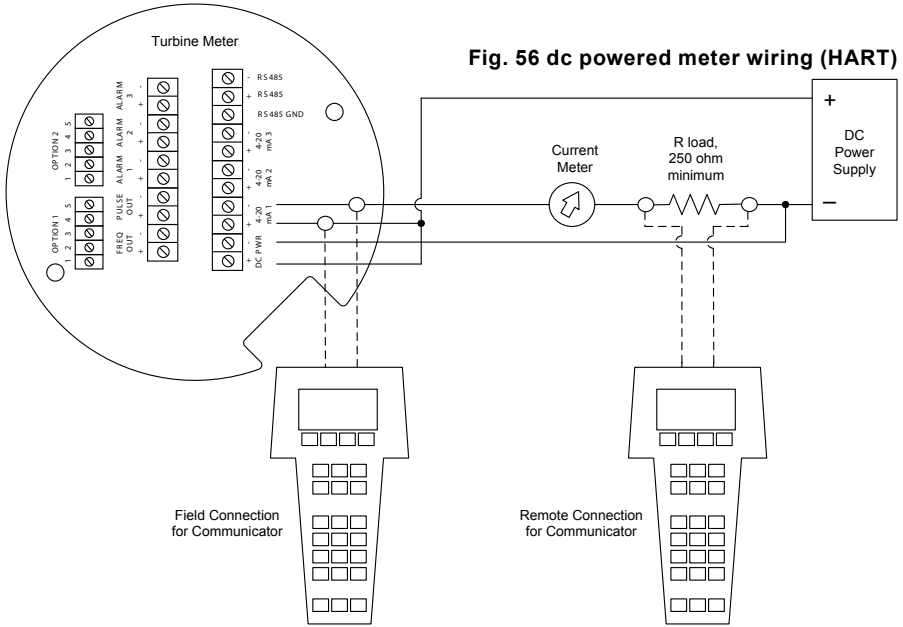
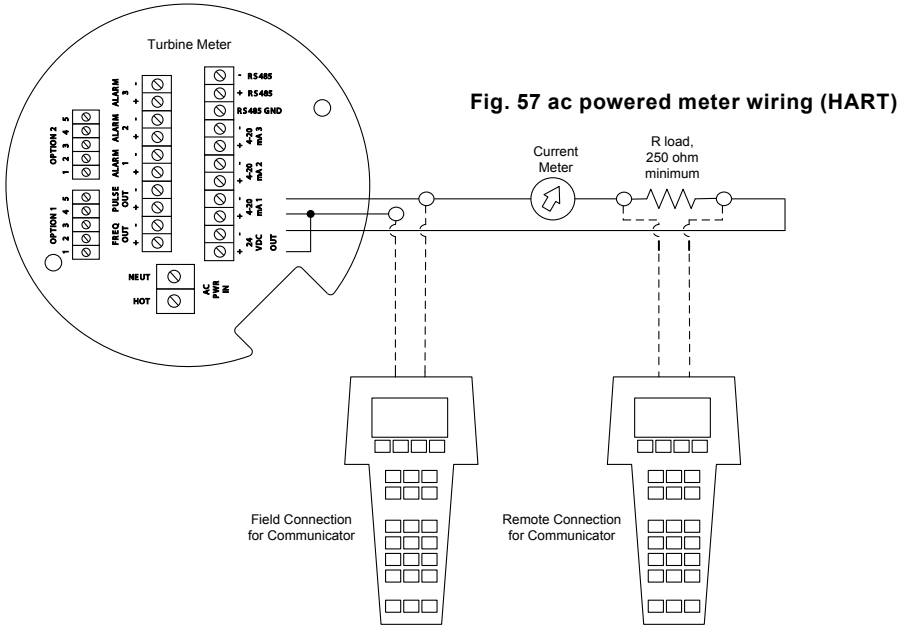

Fig. 55 Loop powered meter wiring (HART)

5.2.2 dc powered meter wiring



5.2.3 ac powered meter wiring



5.3 HART commands with the DD menu

5.3.1 Online Menu

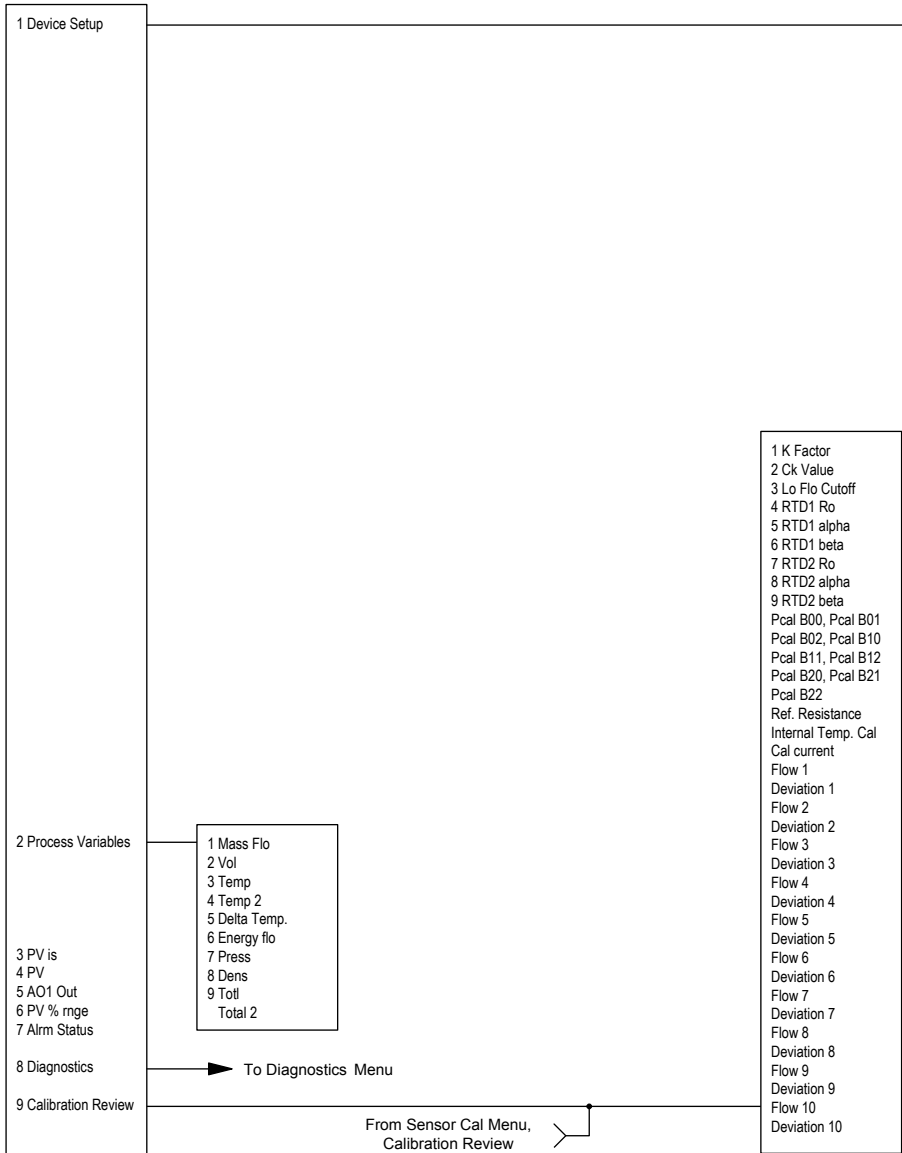

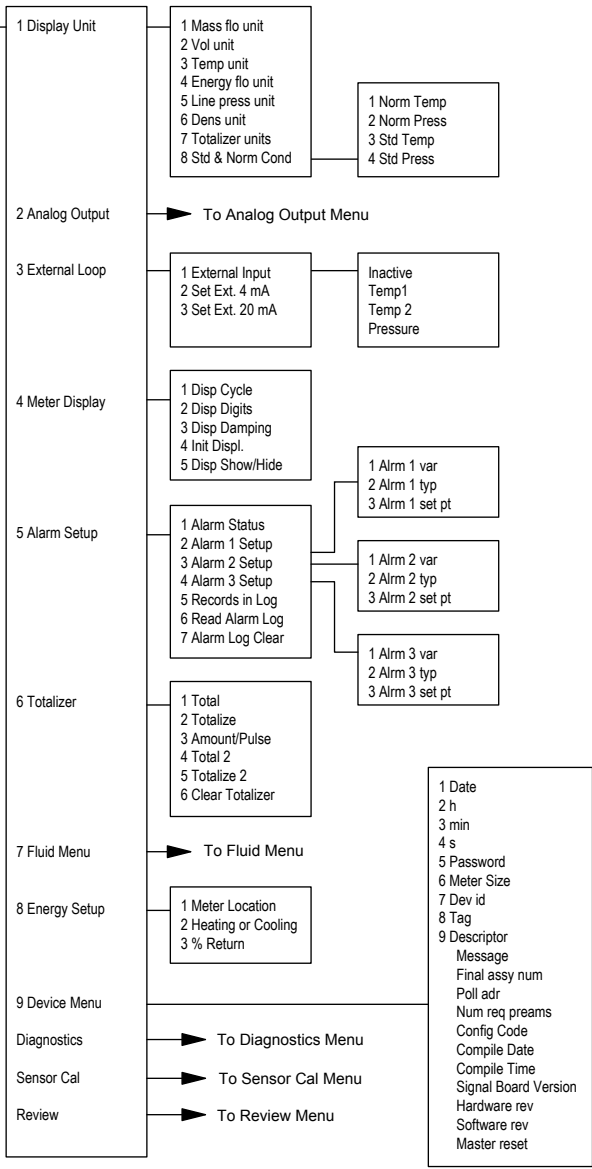

5.3.2 Analogue output menu

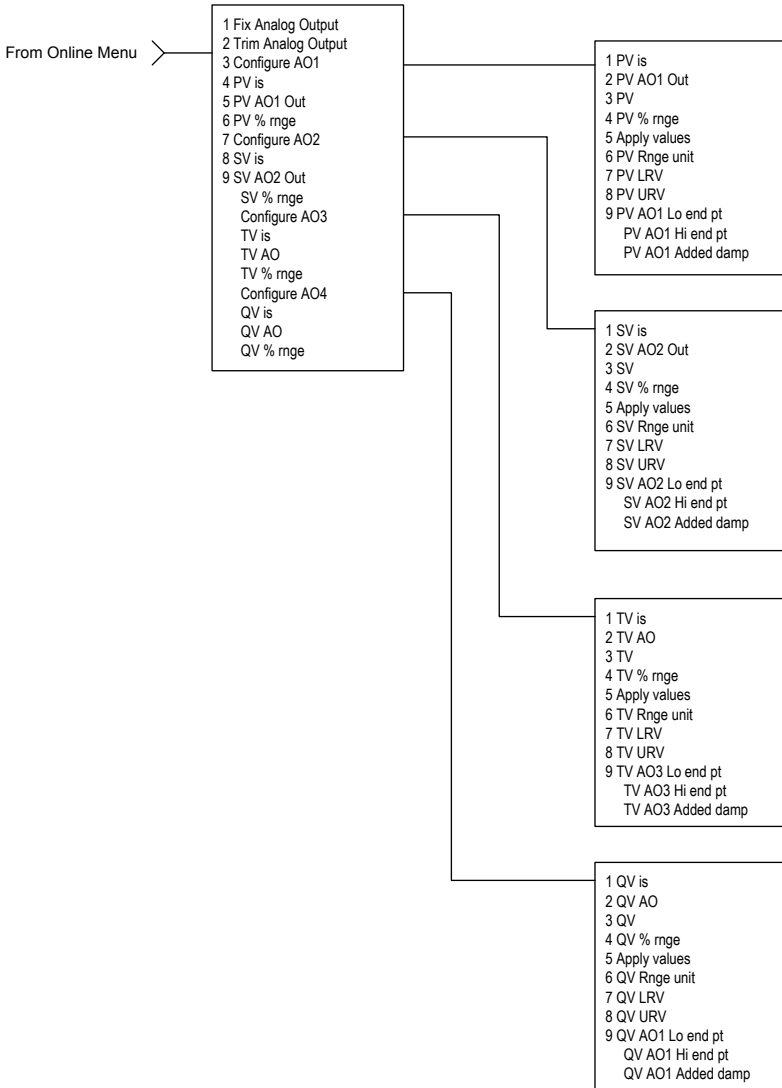

5.3.3 Fluid menu

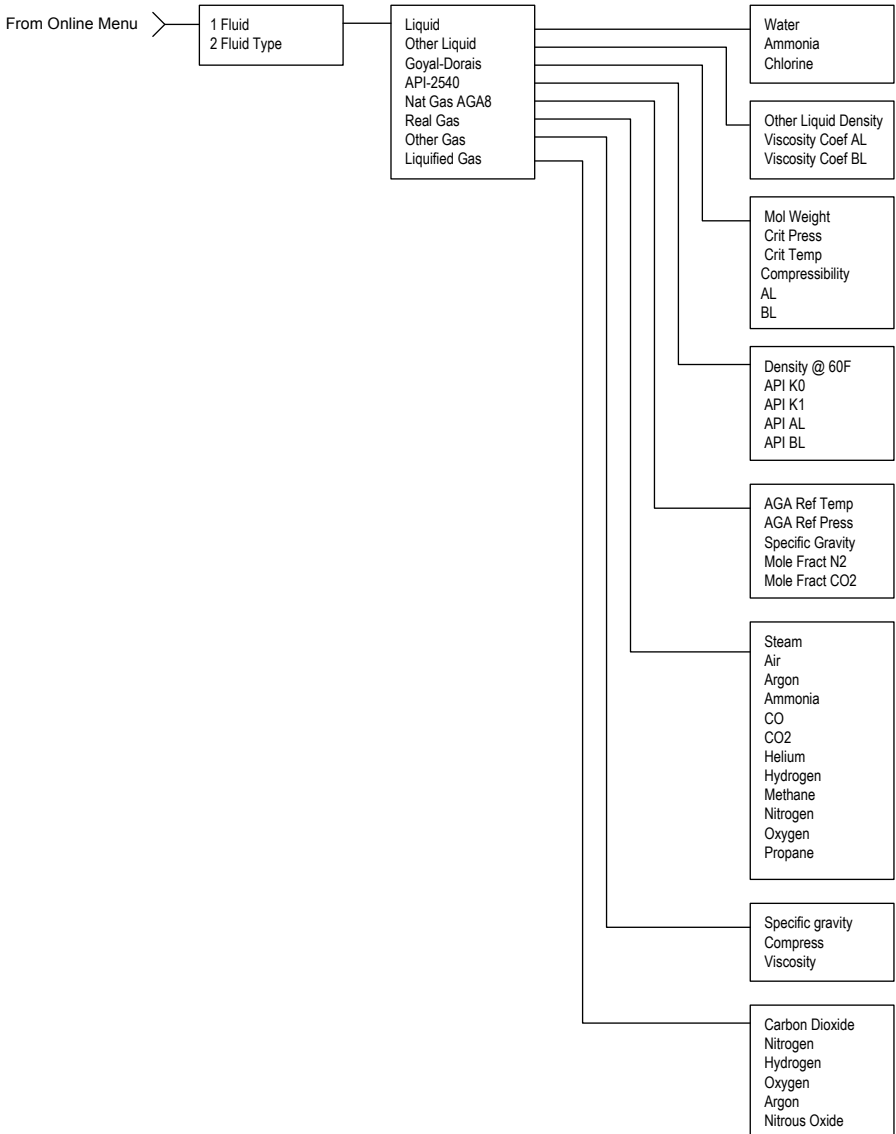

5.3.4 Diagnostics menu

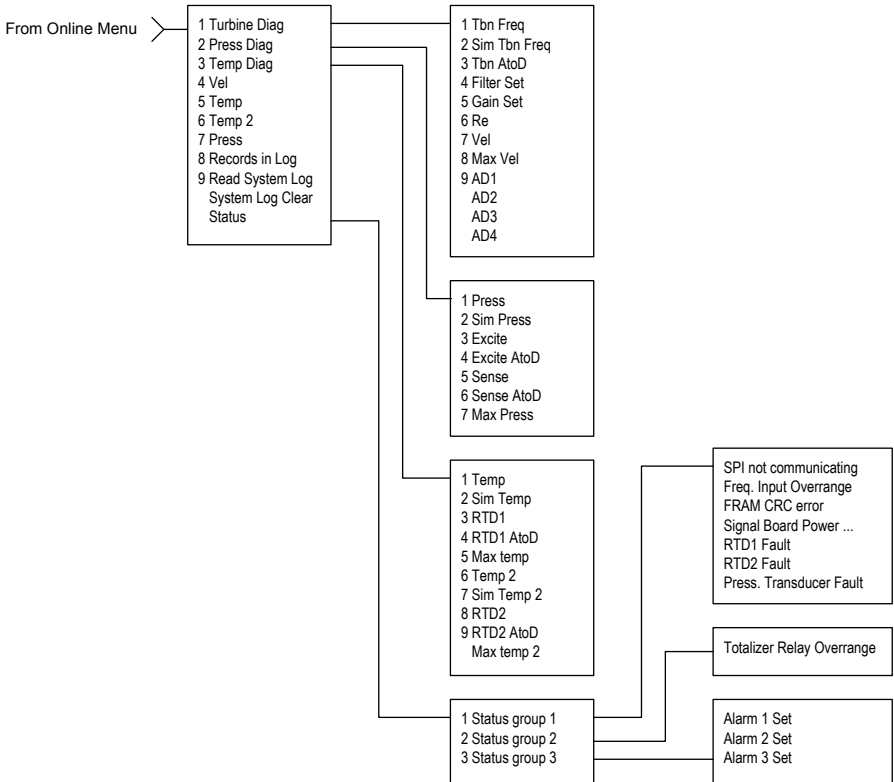

5.3.5 Review menu

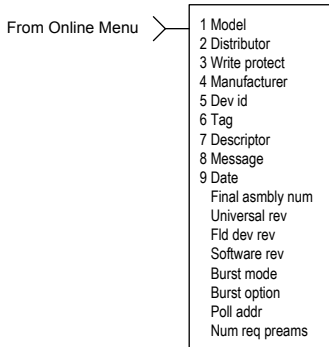

5.3.6 Sensor cal menu

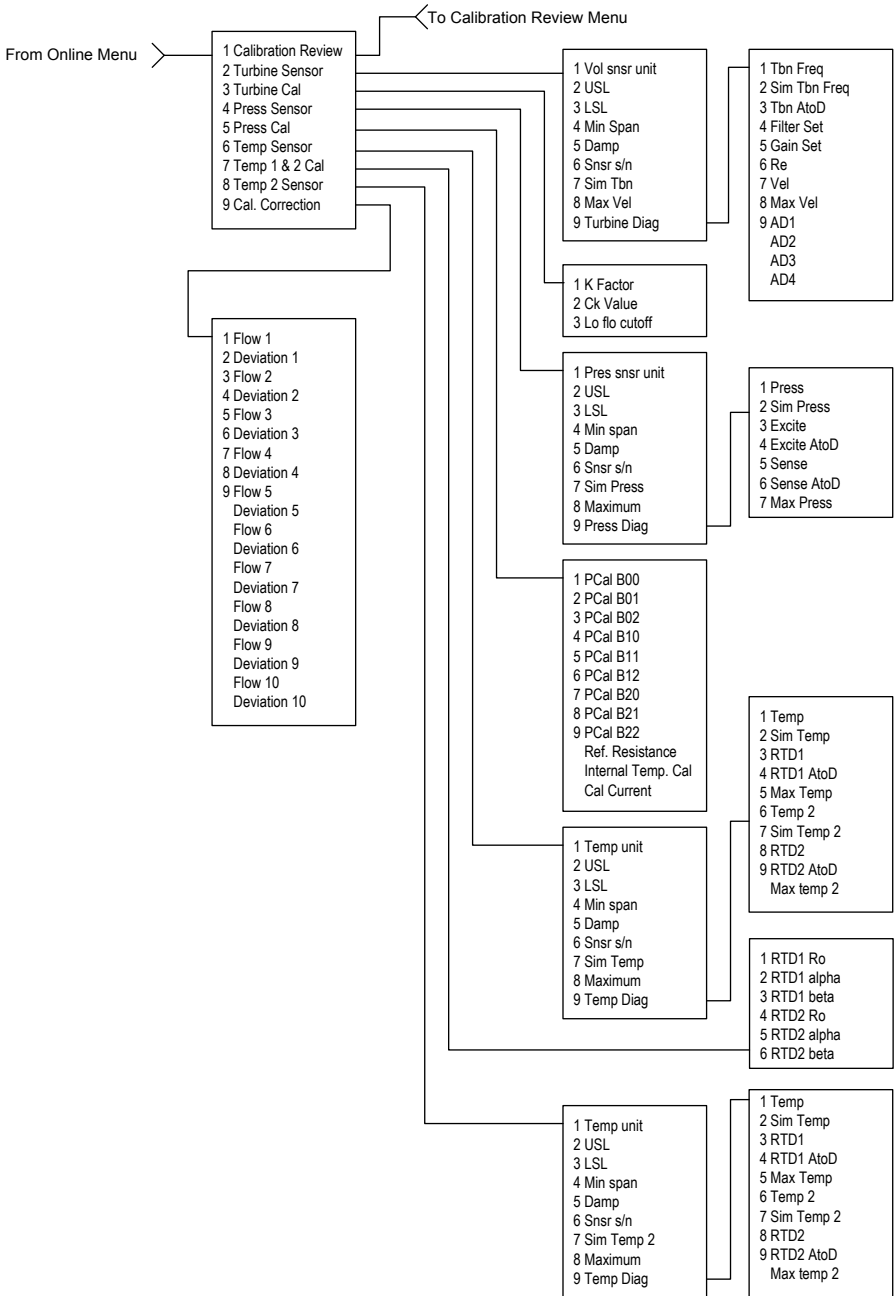

5.4 HART commands with generic DD menu

Online Menu

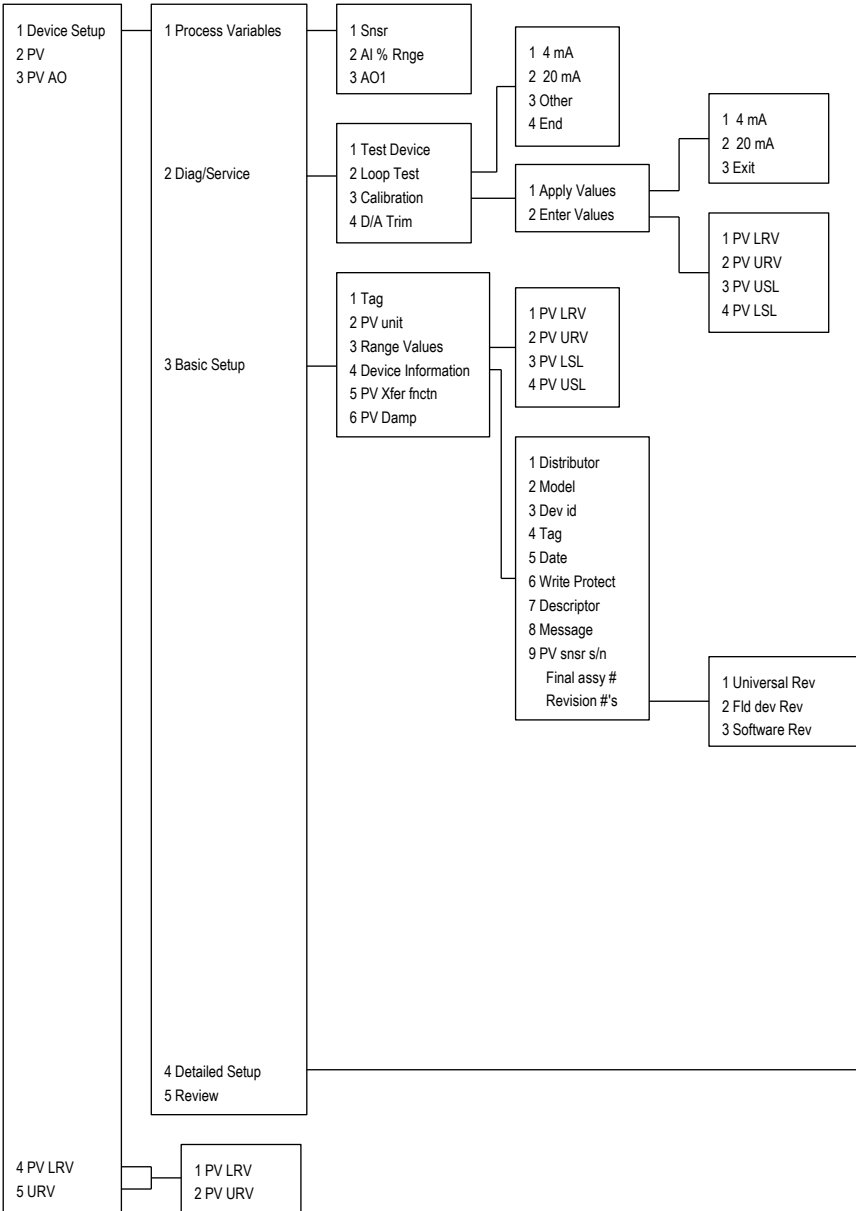

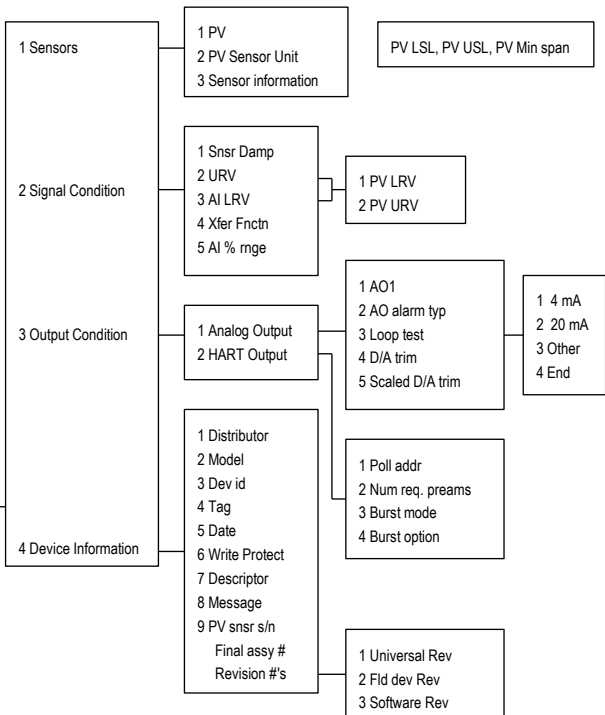

5.4.1 Fast key sequence

Use password 16363.

Sequence	Description	Access	Notes
1,1,1	Snsr	View	Primary variable value
1,1,2	AI % Rnge	View	Analogue output % range
1,1,3	AO1	View	Analogue output, mA
1,2,1	Test Device	N/A	Not used
1,2,2,1	4 mA	View	Loop test, fix Analogue output at 4 mA
1,2,2,2	20 mA	View	Loop test, fix Analogue output at 20 mA
1,2,2,3	Other	Edit	Loop test, fix Analogue output at mA value entered
1,2,2,4	End		Exit loop test
1,2,3,1,1	4 mA	N/A	Not used, apply values
1,2,3,1,2	20 mA	N/A	Not used, apply values
1,2,3,1,3	Exit		Exit apply values
1,2,3,2,1	PV LRV	Edit	Primary variable lower range value
1,2,3,2,2	PV URV	Edit	Primary variable upper range value
1,2,3,2,3	PV USL	View	Primary variable upper sensor limit
1,2,3,2,4	PV LSL	View	Primary variable lower sensor limit
1,2,4	D/A Trim	Edit	Calibrate electronics 4mA and 20mA values
1,3,1	Tag	Edit	Tag
1,3,2	PV unit	Edit	Primary variable units
1,3,3,1	PV LRV	Edit	Primary variable lower range value
1,3,3,2	PV URV	Edit	Primary variable upper range value
1,3,3,3	PV LSL	View	Primary variable upper sensor limit
1,3,3,4	PV USL	View	Primary variable lower sensor limit
1,3,4,1	Distributor	N/A	Not used
1,3,4,2	Model	N/A	Not used
1,3,4,3	Dev id	View	Device identification
1,3,4,4	Tag	Edit	Tag
1,3,4,5	Date	Edit	Date
1,3,4,6	Write Protect	View	Write protect
1,3,4,7	Descriptor	Edit	Turbine flowmeter
1,3,4,8	Message	Edit	32 character alphanumeric message
1,3,4,9	PV snsr s/n	View	Primary variable sensor serial number
1,3,4,menu	Final assy #	Edit	Final assembly number
1,3,4,menu,1	Universal Rev	View	Universal revision
1,3,4,menu,2	Fld dev Rev	View	Field device revision
1,3,4,menu,3	Software Rev	View	Software revision
1,3,5	PV Xfer fnctn	View	Linear
1,3,6	PV Damp	Edit	Primary variable damping (time constant) in seconds

Sequence	Description	Access	Notes
1,4,1,1	PV	View	Primary variable value
1,4,1,2	PV Sensor Unit	Edit	Primary variable units
1,4,1,3	Sensor Information	View	PV LSL, PV USL, PV Min span
1,4,2,1	Snsr Damp	Edit	Primary variable damping (time constant) in seconds
1,4,2,2,1	PV LRV	Edit	Primary variable low range value
1,4,2,2,2	PV URV	Edit	Primary variable upper range value
1,4,2,3,1	PV LRV	Edit	Primary variable low range value
1,4,2,3,2	PV URV	Edit	Primary variable upper range value
1,4,2,4	Xfer Fnctn	View	Linear
1,4,2,5	AI % rng	View	Analogue output % range
1,4,3,1,1	AO1	View	Analogue output, mA
1,4,3,1,2	AO alarm typ	N/A	Not used
1,4,3,1,3,1	4 mA	View	Loop test, fix Analogue output at 4 mA
1,4,3,1,3,2	20 mA	View	Loop test, fix Analogue output at 20 mA
1,4,3,1,3,3	Other	Edit	Loop test, fix Analogue output at mA value entered
1,4,3,1,3,4	End		Exit loop test
1,4,3,1,4	D/A trim	Edit	Calibrate electronics 4mA and 20mA values
1,4,3,1,5	Scaled D/A trim	N/A	Not used
1,4,3,2,1	Poll addr	Edit	Poll address
1,4,3,2,2	Num req. preams	View	Number of required preambles
1,4,3,2,3	Burst mode	N/A	Not used
1,4,3,2,4	Burst option	N/A	Not used
1,4,4,1	Distributor	N/A	Not used
1,4,4,2	Model	N/A	Not used
1,4,4,3	Dev id	View	Device identification
1,4,4,4	Tag	Edit	Tag
1,4,4,5	Date	Edit	Date
1,4,4,6	Write Protect	View	Write protect
1,4,4,7	Descriptor	Edit	Turbine flowmeter
1,4,4,8	Message	Edit	32 character alphanumeric message
1,4,4,9	PV snsr s/n	View	Primary variable sensor serial number
1,4,4,menu	Final assy #	Edit	Final assembly number
1,4,4,menu,1	Universal Rev	View	Universal revision
1,4,4,menu,2	Fld dev Rev	View	Field device revision
1,4,4,menu,3	Software Rev	View	Software revision
1,5	Review	N/A	Not used
2	PV	View	Primary variable value
3	PV AO	View	Analogue output, mA
4,1	PV LRV	Edit	Primary variable lower range value
4,2	PV URV	Edit	Primary variable upper range value
5,1	PV LRV	Edit	Primary variable lower range value
5,2	PV URV	Edit	Primary variable upper range value

5.5 Modbus communications



Warning!

Place controls in manual mode when making configuration changes to the turbine meter.

5.5.1 Applicable flowmeter models

Spirax Sarco's Mass Flowmeters, Models VLM20 and VIM20 with Modbus communication protocol and firmware version 4.00.58 and above.

5.5.2 Overview

This document describes the preliminary implementation of the Modbus communication protocol for use in monitoring common process variables in the Spirax Sarco's Vortex flowmeter. The physical layer utilizes the half-duplex RS-485 port, and the Modbus protocol.

5.5.3 Reference documents

The following documents are available online from www.modbus.org.
Modbus Application Protocol Specification V1.1
Modbus Over Serial Line Specification & Implementation Guide V1.0
Modicon Modbus Protocol Reference Guide PI-MBUS-300 Rev. J

5.5.4 Wiring

An RS485 daisy chained network configuration as depicted below is recommended. Do not use a star, ring, or cluster arrangement.

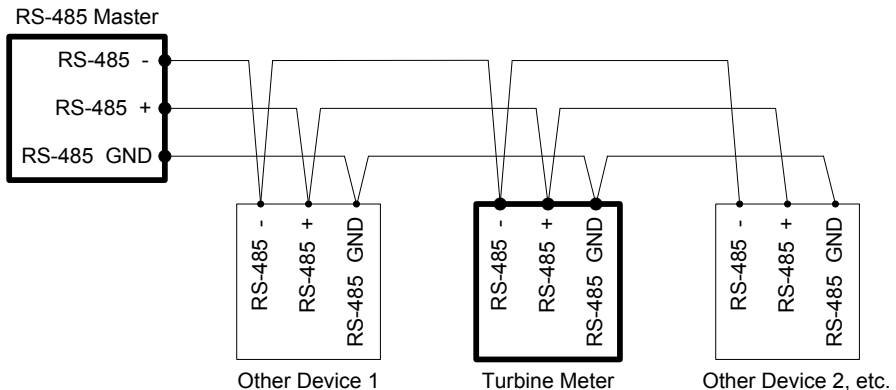

Fig. 58 RS-485 Wiring (MODBUS)

5.5.5 Pin labelling (among devices)

"RS-485 -" = "A" = "TxD-/RxD-" = "Inverting pin"

"RS-485 +" = "B" = "TxD+/RxD+" = "Non-Inverting pin"

"RS-485 GND" = "GND" = "G" = "SC" = "Reference"

5.5.6 Menu Items

The following menu items are in the Output Menu and allow selection and control of the Modbus communication protocol.

5.5.7 Address

When the Modbus protocol is selected, the Modbus address is equal to the user programmable device address if it is in the range 1...247, in accordance with the Modbus specification. If the device address is zero or is greater than 247, then the Modbus address is internally set to 1.

5.5.8 Comm protocol

The Comm Protocol menu allows selection of "Modbus RTU Even," "Modbus RTU Odd," or "Modbus RTU None2," or "Modbus RTU None1," (non-standard Modbus) with Even, Odd and None referring to the parity selection. When even or odd parity is selected, the unit is configured for 8 data bits, 1 parity bit and 1 stop bit; with no parity, the number of stop bits is 1 (non-standard) or 2. When changing the protocol, the change is made as soon as the Enter key is pressed.

5.5.10 Modbus units

The Modbus Units menu is to control what units, where applicable, the meter's variables will be displayed in. Internal - these are the base units of the meter, °F, psi a, lb/sec , ft3 /sec, Btu/sec , lb/ft 3 Display - variables are displayed in user selected display unit.

5.5.11 Modbus order

The byte order within registers and the order in which multiple registers containing floating point or long integer data are transmitted may be changed with this menu item. According to the Modbus specification, the most significant byte of a register is transmitted first, followed by the least significant byte. The Modbus specification does not prescribe the order in which registers are transmitted when multiple registers represent values longer than 16 bits.

Using this menu item, the order in which registers representing floating point or long integer data and/or the byte order within the registers may be reversed for compatibility with some PLCs and PC software.

The following four selections are available in this menu; when selecting an item, the protocol is changed immediately without having to press the Enter key.

0-1:2-3	Most significant register first, most significant byte first (default)
2-3:0-1	Least significant register first, most significant byte first
1-0:3-2	Most significant register first, least significant byte first
3-2:1-0	Least significant register first, least significant byte first

Table 3 Byte order

Note that all of the registers are affected by the byte order, including strings and registers representing 16-bit integers; the register order only affects the order of those registers representing 32-bit floating point and long integer data, but does not affect single 16-bit integers or strings.

5.5.12 Modbus protocol

The Modbus RTU protocol is supported in this implementation. Supported baud rates are 1200, 2400, 4800, 9600, 19200, 38400, 57600, and 115200. The default baud rate is 19200 baud. Depending upon the Modbus protocol selected, data are transmitted in 8-bit data frames with even or odd parity and 1 stop bit, or no parity and 2 or 1 (non-standard) stop bits. The current Modbus protocol specification does not define register usage, but there is an informal register numbering convention derived from the original (now obsolete) Modicon Modbus protocol specification, and used by many vendors of Modbus capable products.

Registers	Usage	Valid function codes
00001-09999	Read/write bits ("coils")	01 (read coils) 05 (write single coil) 15 (write multiple coils)
10001-19999	Read-only bits ("discrete inputs")	02 (read discrete inputs)
30001-39999	Read-only 16 bit registers ("input registers"), IEEE 754 floating point register pairs, arbitrary length strings encoded as two ASCII characters per 16-bit register	03 (read holding registers) 04 (read input registers)
40001-49999	Read/write 16-bit registers ("holding registers"), IEEE 754 floating point register pairs, arbitrary length strings encoded as two ASCII characters per 16-bit register	03 (read holding registers) 06 (write single register) 16 (write multiple registers)

Each range of register numbers maps to a unique range of addresses that are determined by the function code and the register number. The address is equal to the least significant four digits of the register number minus one, as shown in the following table.

Registers	Function codes	Data type and address range
00001-09999	01, 05, 15	Read/write bits 0000-9998
10001-19999	02	Read-only bits 0000-9999
30001-39999	03, 04	Read-only 16-bit registers 0000-9998
40001-49999	03, 06, 16	Read/write 16-bit registers 0000-9998

5.6 Register definitions

The meter serial number and those variables that are commonly monitored (mass, volume and energy flow rates, total, pressure, temperature, density, viscosity, Reynolds number, and diagnostic variables such as frequency, velocity, gain, amplitude and filter setting) are accessible via the Modbus protocol. Long integer and floating point numbers are accessed as pairs of 16-bit registers in the register order selected in the Modbus Order menu. Floating point numbers are formatted as single precision IEEE 754 floating point values.

The flow rate, temperature, pressure, and density variables may be accessed as either the flowmeter internal base units or in the user-programmed display units, which is determined by the programming Output Menu's "Modbus Units" item. The display units strings may be examined by accessing their associated registers. Each of these units string registers contain 2 characters of the string, and the strings may be 2 to 12 characters in length with unused characters set to zero. Note that the byte order affects the order in which the strings are transmitted. If the Modbus Order menu (see page 2) is set to 0-1:2-3 or 2-3:0-1, then the characters are transmitted in the correct order; if set to 1- 0:3-2 or 3-2:1-0, then each pair of characters will be transmitted in reverse order.

Registers	Variable	Data type	Units	Function code	Addresses
65100-65101	Serial number	unsigned long	—	03, 04	
30525-30526	Totalizer	unsigned long	display units*	03, 04	524-525
32037-32042	Totalizer units	string	—	03, 04	2036-2041
30009-30010	Mass flow	float	display units*	03, 04	8-9
30007-30008	Volume flow	float	display units*	03, 04	6-7
30005-30006	Pressure	float	display units*	03, 04	4-5
30001-30002	Temperature	float	display units*	03, 04	0-1
30029-30030	Velocity	float	ft/sec	03, 04	28-29
30015-30016	Density	float	display units*	03, 04	14-15
30013-30014	Viscosity	float	cP	03, 04	12-13
30031-30032	Reynolds number	float	—	03, 04	30-31
30025-30026	Turbine frequency	float	Hz	03, 04	24-25
34532	Gain	char	—	03, 04	4531
30085-30086	Turbine amplitude	float	Vrms	03, 04	84-85
30027-30028	Filter setting	float	Hz	03, 04	26-27

Table 4 Register Definitions

The following registers are available with the energy meter firmware:

Registers	Variable	Data type	Units	Function code	Addresses
30527-30528	Totalizer #2	unsigned long	display units*	03, 04	526-527
32043-32048	Totalizer #2 units	string	—	03, 04	2042-2047
30003-30004	Temperature #2	float	display units*	03, 04	2-3
30011-30012	Energy flow	float	display units*	03, 04	10-11

The following registers contain the display units strings:

Registers	Variable	Data type	Units	Function code	Addresses
32007-32012	Volume flow units	string	—	03, 04	2006-2011
32001-32006	Mass flow units	string	—	03, 04	2000-2005
32025-32030	Temperature units	string	—	03, 04	2024-2029
32019-32024	Pressure units	string	—	03, 04	2018-2023
32031-32036	Density units	string	—	03, 04	2030-2035
32013-32017	Energy flow units	string	—	03, 04	2012-2017

Function codes 03 (read holding registers) and 04 (read input registers) are the only codes supported for reading these registers, and function codes for writing holding registers are not implemented. We recommend that the floating point and long integer registers be read in a single operation with the number of registers being a multiple of two. If these data are read in two separate operations, each reading a single 16-bit register, then the value will likely be invalid.

The floating point registers with values in display units are scaled to the same units as are displayed, but are instantaneous values that are not smoothed. If display smoothing is enabled (non-zero value entered in the Display TC item in the Display Menu), then the register values will not agree exactly with the displayed values.

5.6.1 Exception status definitions

The Read Exception Status command (function code 07) returns the exception status byte, which is defined as follows. This byte may be cleared by setting "coil" register #00003 (function code 5, address 2, data = 0xff00).

Bit(s)	Definition
0-1	Byte order (see Modbus Order on page 2) 0 = 3-2:1-0 1 = 2-3:0-1 2 = 1-0:3-2 3 = 0-1:2-3
2	Temperature sensor fault
3	Pressure sensor fault
4	A/D converter fault
5	Period overflow
6	Pulse overflow
7	Configuration changed

5.6.2 Discrete input definitions

The status of the three alarms may be monitored via the Modbus Read Discrete Input command (function code 02). The value returned indicates the state of the alarm, and will be 1 only if the alarm is enabled and active. A zero value is transmitted for alarms that are either disabled or inactive,

Registers	Variable	Function code	Address
10001	Alarm #1 state	02	0
10002	Alarm #2 state	02	1
10003	Alarm #3 state	02	2

5.6.3 Control register definitions

The only writeable registers in this implementation are the Reset Exception Status, Reset Meter and Reset Totalizer functions, which are implemented as "coils" which may be written with the Write Single Coil command (function code 05) to address 8 through 10, respectively, (register #00009 through #00011).

The value sent with this command must be either 0x0000 or 0xff00, or the meter will respond with an error message; the totalizer will be reset or exception status cleared only with a value of 0xff00.

5.6.4 Error responses

If an error is detected in the message received by the unit, the function code in the response is the received function code with the most significant bit set, and the data field will contain the exception code byte, as follows:

Exception Code	Description
01	Invalid function code — function code not supported by device
02	Invalid data address — address defined by the start address and number of registers is out of range
03	Invalid data value — number of registers = 0 or >125 or incorrect data with the Write Single Coil command

If the first byte of a message is not equal to the unit's Modbus address, if the unit detects a parity error in any character in the received message (with even or odd parity enabled), or if the message CRC is incorrect, the unit will not respond.

5.6.5 Command message format

The start address is equal to the desired first register number minus one. The addresses derived from the start address and the number of registers must all be mapped to valid defined registers, or an invalid data address exception will occur.

Device address	Function code	Start address	N = Number of registers	CRC
8 bits, 1... 247	8 bits	16 bits, 0... 9998	16 bits, 1 ... 125	16 bits

5.6.6 Normal response message format

Device address	Function code	Byte count	Data	CRC
8 bits, 1... 247	8 bits	8 bits	(N) 16-bit registers	16 bits

5.6.7 Exception response message format

Device address	Function code	Exception code	CRC
8 bits, 1... 247	8 bits	8 bits	16 bits

5.6.8 Examples

Read the exception status byte from the device with address 1:

```
01 07 41 E2
01 Device address
07 Function code,
04 = read exception status
```

A typical response from the device is as follows:

```
01 07 03 62 31
01 Device address
07 Function code
03 Exception status byte
62 31 CRC
```

Request the first 12 registers from device with address 1:

```
01 04 00 00 00 0C F0 0F
01 Device address
04 Function code, 04 = read input register
00 00 Starting address
00 0C Number of registers = 12
F0 0F CRC
```

A typical response from the device is as follows: *note these are the older register definitions

```
01 04 18 00 00 03 E8 00 00 7A 02 6C 62 00 00 41 BA 87 F2 3E BF
FC 6F 42 12 EC 8B 4D D1
01 Device address
04 Function code
18 Number of data bytes = 24
00 00 03 E8 Serial number = 1000 (unsigned long)
00 00 7A 02 Totalizer = 31234 lb (unsigned long)
6C 62 00 00 Totalizer units ="lb" (string, unused characters
are 0)
41 BA 87 F2 Mass flowrate = 23.3164 lb/sec (float)
3E BF FC 6F Volume flowrate = 0.3750 ft3 /sec (float)
42 12 EC 8B Pressure = 36.731 psi a (float)
4D D1 CRC
```

An attempt to read register(s) that don't exist

```
01 04 00 00 00 50 F1 D2
01 Device address
04 Function code 4 = read input register
00 00 Starting address
00 50 Number of registers = 80
F0 36 CRC
```

results in an error response as follows:

```
01 84 02 C2 C1
01 Device address
84 Function code with most significant bit set indicates
error response
02 Exception code 2 = invalid data address
C2 C1 CRC
```

Request the state all three alarms:

```
01 02 00 00 00 03 38 0B
01 Device address
02 Function code 2 = read discrete inputs
00 00 Starting address
00 03 Number of inputs = 3
38 0B CRC
```

and the unit responds with:

```
01 02 01 02 20 49
01 Device address
02 Function code
01 Number of data bytes = 1
02 Alarm #2 on, alarms #1 and #3 off
20 49 CRC
```

To reset the totalizer:

```
01 05 00 00 FF 00 8C 3A
01 Device address
05 Function code 5 = write single coil
00 09 Coil address = 9
FF 00 Data to reset totalizer
8C 3A CRC (not the correct CRC EJS-02-06-07)
```

The unit responds with an identical message to that transmitted, and the totalizer is reset. If the "coil" is turned off as in the following message, the response is also identical to the transmitted message, but the totalizer is not affected.

```
01 05 00 00 00 00 CD CA
01 Device address
05 Function code 5 = write single coil
00 00 Coil address = 0
00 00 Data to "turn off coil" does not reset totalizer
CD CA CRC
```

5.7 BACnet MS/TP communications

The BACnet Master-Slave/Token-Passing (MS/TP) driver implements a data link protocol that uses the services of the RS-485 physical layer. The MS/TP bus is based on BACnet standard protocol SSPC-135, Clause 9. BACnet MS/TP protocol is a peer-to-peer, multiple master protocols based on token passing. Only master devices can receive the token, and only the device holding the token is allowed to originate a message on the bus. The token is passed from master device to master device using a small message.

The token is passed in consecutive order starting with the lowest address. Slave devices on the bus only communicate on the bus when responding to a data request from a master device.

5.8 Baud rates on the MS/TP Bus

An MS/TP bus can be configured to communicate at one of four different baud rates. It is very important that all of the devices on an MS/TP bus communicate at the same baud rate. The baud rate setting determines the rate at which devices communicate data over the bus. The baud rate settings available on RIM20 Vortex Mass flowmeters are 9600, 19200, 38400, 57600 and 115200

5.8.1 Baud Rate and MAC address configuration

1. Power on the IUT
2. Press Enter to go configuration menu
3. Give the factory password 16363 (Use Up and Down arrows to enter the digits)
4. Navigate to Output menu
5. Navigate to Output Menu by using right or left arrow buttons
6. Press Down button and reach Baud Rate and MAC address screens and Device Instance
7. Change the required settings and press Exit & Enter buttons to save the configuration
8. Do steps from b to g, and change the comm. Type as Hart.
9. Reboot the device by power off and on.
Note:
 - a. IUT support 9600, 19200, 38400, 57600 and 115200 baud rates
 - b. MAC address range is 0-127

5.9 Supported BACnet objects

A BACnet object represents physical or virtual equipment information, as a digital input or parameters. The Spirax Sarco Vortex Mass flowmeters presents the following object types:

- a. Device Object
- b. Analogue Input
- c. Binary Input
- d. Binary Value

Each object type defines a data structure composed by properties that allow the access to the object information. The below table shows the implemented properties for each Vortex Mass flowmeters object type.

Properties	Object Types			
	Device	Analogue input	Binary input	Binary value
Object_Identifier	<input checked="" type="checkbox"/>	<input checked="" type="checkbox"/>	<input checked="" type="checkbox"/>	<input checked="" type="checkbox"/>
Object_Name	<input checked="" type="checkbox"/>	<input checked="" type="checkbox"/>	<input checked="" type="checkbox"/>	<input checked="" type="checkbox"/>
Object_Type	<input checked="" type="checkbox"/>	<input checked="" type="checkbox"/>	<input checked="" type="checkbox"/>	<input checked="" type="checkbox"/>
System_Status	<input checked="" type="checkbox"/>			
Vendor_Name	<input checked="" type="checkbox"/>			
Vendor_Identifier	<input checked="" type="checkbox"/>			
Model_Name	<input checked="" type="checkbox"/>			
Firmware_Revision	<input checked="" type="checkbox"/>			
Application-Software-Version	<input checked="" type="checkbox"/>			
Protocol_Version	<input checked="" type="checkbox"/>			
Protocol_Revision	<input checked="" type="checkbox"/>			
Protocol_Services_Supported	<input checked="" type="checkbox"/>			
Protocol_Object_Types_Supported	<input checked="" type="checkbox"/>			
Object_List	<input checked="" type="checkbox"/>			
Max_ADPU_Length_Accepted	<input checked="" type="checkbox"/>			
Segmentation_Supported	<input checked="" type="checkbox"/>			
ADPU_Timeout	<input checked="" type="checkbox"/>			
Number_Of_ADPU_Retries	<input checked="" type="checkbox"/>			

Properties	Object Types			
	Device	Analogue input	Binary input	Binary value
Max_Masters	<input checked="" type="checkbox"/>			
Max_Info_Frames	<input checked="" type="checkbox"/>			
Device_Address_Binding	<input checked="" type="checkbox"/>			
Database_Revision	<input checked="" type="checkbox"/>			
Status_Flags				
Event_State		<input checked="" type="checkbox"/>	<input checked="" type="checkbox"/>	<input checked="" type="checkbox"/>
Reliability				
Out_Of_Service		<input checked="" type="checkbox"/> (W)	<input checked="" type="checkbox"/> (W)	<input checked="" type="checkbox"/> (W)
Units		<input checked="" type="checkbox"/>		
Polarity			<input checked="" type="checkbox"/> (W)	
Priority_Array				
Relinquish_Default				
Status_Flag		<input checked="" type="checkbox"/>	<input checked="" type="checkbox"/>	<input checked="" type="checkbox"/>
Present_Value		<input checked="" type="checkbox"/> (W)	<input checked="" type="checkbox"/> (W)	<input checked="" type="checkbox"/> (W)
Inactive_Text				
Active_Text				

(W) - Writable Property.

5.9.1 Device object:

The Device object default property values are as follows -

Property name	Default values			
object-identifier	7			
object-name	Device,1			
object-type	Device			
system-status	operational			
vendor-name	Spirax Sarco			
vendor-identifier	558			
model-name	Multivariable Flowmete			
firmware-revision	N/A			
application-software-				
version	1.07			
protocol-version	1			
protocol-revision	4			
protocol-services-				
supported	{F,F,F,F,F,F,F,F,F,F,F,F,T,F,T,T,T,F,F,F,F,F,F,F,F,F,F,F,T,T,F,F,F,F,F}			
protocol-object-types-supported	{T,F,F,T,F,T,F,F,T,F,F,F,F,F,F,F,F,F,F,F,F,F,F}			
object-list	<table border="0"> <tr> <td>{(Analogue-input,1), (Analogue-input,2), (Analogue-input,3), (Analogue-input,4), (Analogue-input,5), (Analogue-input,6), (Analogue-input,7), (Analogue-input,8), (Analogue-input,9),</td> <td>(Analogue-input,10), (Analogue-input,11), (Analogueinput, 12), (Analogue-input,13), (Analogue-input,14), (Analogueinput, 15), (Analogue-input,16), (Analogue-input,17),</td> <td>(Analogueinput, 18), (Analogue-input,19), (binary-input,1), (binary-input,2), (binaryinput, 3), (binary-input,4), (binary-value,1), (device,7) }</td> </tr> </table>	{(Analogue-input,1), (Analogue-input,2), (Analogue-input,3), (Analogue-input,4), (Analogue-input,5), (Analogue-input,6), (Analogue-input,7), (Analogue-input,8), (Analogue-input,9),	(Analogue-input,10), (Analogue-input,11), (Analogueinput, 12), (Analogue-input,13), (Analogue-input,14), (Analogueinput, 15), (Analogue-input,16), (Analogue-input,17),	(Analogueinput, 18), (Analogue-input,19), (binary-input,1), (binary-input,2), (binaryinput, 3), (binary-input,4), (binary-value,1), (device,7) }
{(Analogue-input,1), (Analogue-input,2), (Analogue-input,3), (Analogue-input,4), (Analogue-input,5), (Analogue-input,6), (Analogue-input,7), (Analogue-input,8), (Analogue-input,9),	(Analogue-input,10), (Analogue-input,11), (Analogueinput, 12), (Analogue-input,13), (Analogue-input,14), (Analogueinput, 15), (Analogue-input,16), (Analogue-input,17),	(Analogueinput, 18), (Analogue-input,19), (binary-input,1), (binary-input,2), (binaryinput, 3), (binary-input,4), (binary-value,1), (device,7) }		
max-apdu-length-accepted	300			
segmentation-supported	no-segmentation			
apdu-timeout	3000			
number-of-APDU-retries	1			
max-master	127			
max-info-frames	1			
device-address-binding	()			
database-revision	0			

Note - Device Communication Control: Password -"Spirax Sarco"

5.9.2 Analogue input object:

Vortex Mass flowmeters Analogue Input type objects are described in the below Table -

Object instance	Object name	Unit	Description
1	Volume flow	cubic-feet-per-second, cubic-feet-per-minute, us-gallons-per-minute, imperial-gallons-per- minute, litres-per-minute, litres-per-second, litres-per-hour, cubic-meters-per-second, cubic-meters-per-minute, cubic-meters-per-hour	This AI object is used to measure volume flow.
2	Mass flow	pounds-mass-per-second, grams-per-second, kilograms-per-second , kilograms-per-minute , kilograms-per-hour, pounds-mass-per-minute , pounds-mass-per-hour, tons-per-hour, grams-per-second , grams-per-minute	This AI object is used to measure mass flow.
3	Temperature 1	degrees-Celsius, degrees-Kelvin, degrees-Fahrenheit	This AI object measures temperature in one of the given Unit.
4	Temperature 2	degrees-Celsius, degrees-Kelvin, degrees-Fahrenheit	This AI object measures temperature in one of the given Unit.
5	Pressure	pounds-force-per-square-" "-of-water, "-of-mercury, millimeters-of-mercury, bars, millibars, pascals, kilopascals	TBD
6	Density	kilograms-per-cubic-meter	TBD
7	Energy Flow	Kilowatts, Horsepower, btus-per-hour,, kilo-btus-per-hour, megawatts	TBD

Object instance	Object name	Unit	Description
8	Totalizer 1 & Totalizer 2	<p>If Totalizer selection for Mass measure - pounds-mass-per-second, grams-per-second, kilograms-per-second , kilograms-per-minute , kilograms-per-hour, pounds-mass-per-minute , pounds-mass-per-hour, tons-per-hour, grams-per-second , grams-per-minute</p> <p>If Totalizer selection for Volume measure - cubic-feet-per-second, cubic-feet-per-minute, us-gallons-per-minute, imperial-gallons-per-minute, litres-per-minute, litres-per-second, litres-per-hour, cubic-meters-per-second, cubic-meters-per-minute, cubic-meters-per-hour</p> <p>If Totalizer selection for Energy measure - Kilowatts, Horsepower, btus-per-hour,, kilo-btus-per-hour, megawatts</p>	An electronic counter which records the total accumulated flow over a certain range of time.
10	StatusRegister	NO UNITS	TBD
11	Channel 1 (4-20mA)	milliamperes	TBD
12	Channel 2 (4-20mA)	milliamperes	TBD
13	Channel 3 (4-20mA)	milliamperes	TBD
14	Scaled Freq	hertz	TBD
15	Flow Velocity	feet-per-second	TBD
16	Viscosity	centipoises	TBD
17	Frequency	hertz	TBD
18	VorTex Amp	millivolts	TBD
19	FilterSetting	hertz	TBD

5.9.3 Binary input object:

Vortex Mass flowmeters Binary Input type objects are described in the below Table.

Object instance	Object name	Description
1	Alarm1	The status of the three alarms may be monitored via the Modbus command. The value returned indicates the state of the alarm, and will be 1 only if the alarm is enabled and active. A zero value is transmitted for alarms that are either disabled or inactive
2	Alarm2	
3	Alarm3	
4	External	TBD

Note - Binary Input 4, Present value always read zero, because no information available from client, so the polarity property doesn't impact on Present value property when the Out of service property is false.

5.9.4 Binary value object:

Vortex Mass flowmeters Binary Value type objects are described in the below Table.

Object instance	Object name	Description
1	Reset	Reset's Totalizer

5.10 ANNEX - BACnet protocol implementation conformance statement

Date: 19-April-2012

Applications Software Version: 1.07

Firmware Revision: N/A

BACnet Protocol Revision: 4

BACnet Standardized Device Profile (Annex L):

- BACnet Operator Workstation (B-OWS)
- BACnet Advanced Operator Workstation (B-AWS)
- BACnet Operator Display (B-OD)
- BACnet Building Controller (B-BC)
- BACnet Advanced Application Controller (B-AAC)
- BACnet Application Specific Controller (B-ASC)
- BACnet Smart Sensor (B-SS)
- BACnet Smart Actuator (B-SA)

5.10.1 List all BACnet interoperability building blocks supported (Annex K):

BIBBs
DS-RP-B
DS-WP-B
DM-DDB-B
DM-DOB-B
DM-DCC-B
DS-RPM-B
DS-WPM-B

Services supported	
Read Property	Execute
Write Property	Execute
Read Property Multiple	Execute
Write Property Multiple	Execute
Who-Is	Execute
I-Am	Initiate
Who-Has	Execute
I-Have	Initiate
Device Communication Control	Execute

5.10.2 Segmentation capability:

- Able to transmit segmented messages Window Size
- Able to receive segmented messages Window Size

5.10.3 Standard object types supported

Standard object types supported				
Object type	Dynamically creatable	Dynamically deleteable	Additional writable properties	Range restrictions
Analogue Input (AI)	No	No	None	None
Binary Input (BV)	No	No	None	None
Binary Value	No	No	None	None
Device	No	No	None	None

Standard object types supported writable properties			
Object type	Properties		
Analogue Input (AI)	Present Value	Out-Of-Service	
Binary Input (BV)	Present Value	Out-Of-Service	Polarity
Binary Value	Present Value	Out-Of-Service	
Device			

5.10.4 Object list

Properties of Analogue Input/Value Objects Type						
ID	Name	Present value	Status flags	Event state	Out of service	Units
A11	Volume Flow	?	F,F,F,F	Normal	False	?
A12	Mass Flow	?	F,F,F,F	Normal	False	?
A13	Temperature 1	?	F,F,F,F	Normal	False	?
A14	Temperature 2	?	F,F,F,F	Normal	False	?
A15	Pressure	?	F,F,F,F	Normal	False	?
A16	Density	?	F,F,F,F	Normal	False	?
A17	Energy Flow	?	F,F,F,F	Normal	False	?
A18	Totalizer 1	?	F,F,F,F	Normal	False	?
A19	Totalizer 2	?	F,F,F,F	Normal	False	?
A110	StatusRegister	?	F,F,F,F	Normal	False	?
A111	Channel 1 (4-20mA)	?	F,F,F,F	Normal	False	?
A112	Channel 2 (4-20mA)	?	F,F,F,F	Normal	False	?
A113	Channel 3 (4-20mA)	?	F,F,F,F	Normal	False	?
A114	Scaled Freq	?	F,F,F,F	Normal	False	?
A115	Flow Velocity	?	F,F,F,F	Normal	False	?
A116	Viscosity	?	F,F,F,F	Normal	False	?
A117	Frequency	?	F,F,F,F	Normal	False	?
A118	VorTex Amp	?	F,F,F,F	Normal	False	?
A119	FilterSetting	?	F,F,F,F	Normal	False	?

Properties of Analogue Input/Value Objects Type						
ID	Name	Present value	Status flags	Event state	Out of service	Polarity
B11	Alarm1	?	F,F,F,F	Normal	False	Normal
B12	Alarm2	?	F,F,F,F	Normal	False	Normal
B13	Alarm3	?	F,F,F,F	Normal	False	Normal
B14	External	?	F,F,F,F	Normal	False	Normal

Properties of Analogue Input/Value Objects Type						
ID	Name	Present value	Status flags	Event fstate	Out of fervice	out-of-service
BV1	Reset	?	F,F,F,F	Normal	False	False

5.10.5 Data link layer options:

- BACnet IP, (Annex J)
- BACnet IP, (Annex J), Foreign Device
- ISO 8802-3, Ethernet (Clause 7)
- ANSI/ATA 878.1, 2.5 Mb. ARCNET (Clause 8)
- ANSI/ATA 878.1, EIA-485 ARCNET (Clause 8), baud rate(s)
- MS/TP master (Clause 9), baud rate(s): 9600, 19200, 38400
- MS/TP slave (Clause 9), baud rate(s):
- Point-To-Point, EIA 232 (Clause 10), baud rate(s):
- Point-To-Point, modem, (Clause 10), baud rate(s):
- LonTalk, (Clause 11), medium:
- Other:

5.10.6 Device address binding:

Is static device binding supported? (This is currently necessary for two- way communication with MS/TP slaves and certain other devices.) :

- Yes No

5.10.7 Networking options:

- Router, Clause 6 - List all routing configurations, e.g., ARCNET- Ethernet, Ethernet-MS/TP, etc.
- Annex H, BACnet Tunneling Router over IP
- BACnet/IP Broadcast Management Device (BBMD)
 - Does the BBMD support registrations by Foreign Devices? Yes No
 - Does the BBMD support network address translation? Yes No

5.10.8 Network security options:

- Non-secure Device - is capable of operating without BACnet Network Security
- Secure Device - is capable of using BACnet Network Security (NS-SD BVBB)
- Multiple Application-Specific Keys:
- Supports encryption (NS-ED BVBB)
- Key Server (NS-KS BVBB)

5.10.9 Character sets supported:

Indicating support for multiple character sets does not imply that they can all be supported simultaneously.

- ANSI X3.4
- IBM™/Microsoft™DBCS
- ISO 8859-1
- ISO 10646 (UCS-2)
- ISO 10646 (UCS-4)
- JIS C 6226

If this product is a communication gateway, describe the types of non- BACnet equipment/networks(s) that the gateway supports:

N/A

5.11 Acronyms and definitions

Item	Description
APDU	Application Protocol Data Unit
BACnet	Building Automation and Control Network- Data communication protocol
MS/TP	Master-Slave Token passing(a twisted pair RS485 network created by BACnet)
BIBB	BACnet Interoperability Building Block (Specific individual function blocks for data exchange between interoperable devices).
BV	Binary Value
BI	Binary Input
AI	Analogue Input
RP	Read Property
WP	Write Property
RPM	Read Property Multiple
WPM	Write Property Multiple.
DDB	Dynamic Device Binding
DOB	Dynamic Object Binding
DCC	Device communication Control

6. Troubleshooting and repair



Warning!

Before attempting any flowmeter repair, verify that the line is not pressurized. Always remove main power before disassembling any part of the mass flowmeter.

6.1 Hidden diagnostics menus

The menus shown on the following page can be accessed using the password 16363, then moving to the display that reads "Diagnostics Menu" and pressing ENTER (rather than one of the arrow keys).

Use the right arrow key to move to the second column. Press EXIT to move from the second column back to the first, press EXIT while in the first column to return to the setup menus. Caution: password 16363 will allow full access to the configuration and should be used carefully to avoid changes that can adversely alter the function of the meter.

Each of the menus on the following page will first be defined followed by specific troubleshooting steps.

Level one values

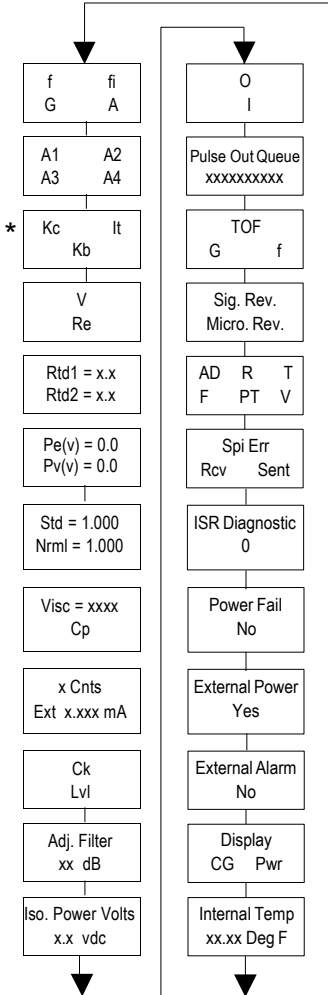

Level two values

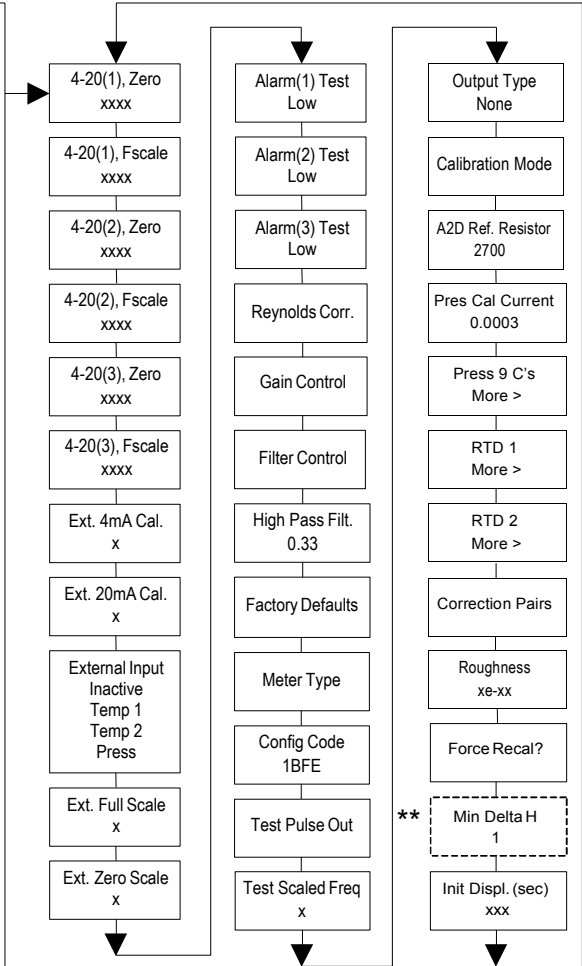

* Not present on VLM20s

** Energy EM Meters Only

6.2 Level one hidden diagnostics values

- f = Vortex shedding frequency (Hz).
- f_i = Adaptive filter - should be approximately 25% higher than the vortex shedding frequency, this is a low-pass filter. If the meter is using the Filter Control (see below) in the manual mode, f_i will be displayed as f_m .
- G = Gain (applied to vortex signal amplitude). Gain defaults to 1.0 and can be changed using the Gain Control (see below).
- A = Amplitude of vortex signal in Volts rms.
- A_1, A_2, A_3, A_4 = A/D counts representing the vortex signal amplitude. Each stage (A_1 - A_4) cannot exceed 512. Beginning with stage A_1 , the A/D counts increase as the flow increases.
When stage A_1 reaches 512, it will shift to stage A_2 . This will continue as the flow rate increases until all 4 stages read 512 at high flow rates. Higher flow rates (stronger signal strength) will result in more stages reading 512.
- K_c, I_t, K_b = Profile equation (factory use only). Model VIM20 only
- V = Calculated average pipe velocity (ft/sec).
- Re = Calculated Reynolds number.
- $RTD1$ = Resistance value of integral RTD in ohms.
- $RTD2$ = Optional RTD resistance value in ohms.
- $P_e(v)$ = Pressure transducer excitation voltage
- $P_v(v)$ = Pressure transducer sense voltage.
- $Stnd$ = Density of fluid at standard conditions.
- $Nrml$ = Density of fluid at normal conditions.
- $Viscosity$ = Calculated viscosity of flowing fluid.
- $x\ Cnts$ = A/D counts from the external 4-20 mA input.
- $Ext\ x.xxx\ mA$ = Calculated external 4-20 mA input from the digital counts.
- Ck = Calculated Ck at current operating conditions. Ck is a variable in the equation that relates signal strength, density, and velocity for a given application. It is used for noise rejection purposes. Ck directly controls the f_i value (see above). If the Ck is set too low (in the calibration menu), then the f_i value will be too low and the vortex signal will be rejected resulting in zero flow rate being displayed. The calculated Ck value in this menu can be compared to the actual Ck setting in the calibration menu to help determine if the Ck setting is correct.

- Lvl = Threshold level. If the Low Flow Cutoff in the calibration menu is set above this value, the meter will read zero flow. The Lvl level can be checked at no flow. At no flow, the Lvl must be below the Low Flow Cutoff setting or the meter will have an output at no flow.
- Adj. Filter = Adjustable filter. Displays the filtering in decibels. Normally reads zero. If this value is consistently -5 or -10, for example, the Ck or density setting may be wrong.
- Iso. Power Volts = Nominally 2.7 Vdc, if less than this check the flowmeter input power.
- O,I = Factory use only.
- Pulse Out Queue = Pulse output queue. This value will accumulate if the totalizer is accumulating faster than the pulse output hardware can function. The queue will allow the pulses to "catch up" later if the flow rate decreases. A better practice is to slow down the totalizer pulse by increasing the value in the (unit)/pulse setting in the totalizer menu.
- TOF, G, f = Factory use only.
- Sig. Rev = Signal board hardware and firmware revision.
- Miro Rev = Microprocessor board hardware and firmware revision.
- AD, R, T, F, PT, V = Factory use only.
- SPI Err, Rcv, Sent = Factory use only.
- ISR Diagnostic = Factory use only.
- Power Fail = Factory use only.
- External Power = Factory use only.
- External Alarm = Factory use only.
- Display CG, PWR = Factory use only.
- Internal Temperature = Electronics temperature.

6.3 Level two hidden diagnostics values

- 4-20(1) Zero = Analogue counts to calibrate zero on analog output 1.
- 4-20(1) FScale = Analogue counts to cal. full scale on analog output 1.
- 4-20(2) Zero = Analogue counts to calibrate zero on analog output 2.
- 4-20(2) FScale = Analogue counts to cal. full scale on analog output 2.
- 4-20(3) Zero = Analogue counts to calibrate zero on analog output 3.
- 4-20(3) FScale = Analogue counts to cal. full scale on analog output 3.
- Ext. 4 mA Cal. = Enter 0 for auto calibration or enter factory supplied A/D counts. Note: You must connect a known 4.00 mA input if you are going to calibrate the unit.
- Ext. 20 mA Cal. = Enter 0 for auto calibration or enter factory supplied A/D counts. Note: You must connect a known 20.00 mA input if you are going to calibrate the unit.
- External Input = Enter what the external 4-20 mA input represents, i.e. Temperature 1, Temperature 2, or Pressure. The meter will use this for its internal calculations.
- Ext. Full Scale = Enter the full scale units that correlate to the 20 mA point. Note: It must be in the units for the selected input type such as Deg F, Deg C, Psi a, Bar A, etc.
- Ext. Zero Scale = Same as above but for the 4 mA point.
- Alarm (1) Test = Used as a test to verify that the alarm circuit is functioning. When low is selected the alarm will initiate a low alarm on the output. When High is selected it will give a high alarm on the output.
- Alarm (2) Test = Used as a test to verify that the alarm circuit is functioning. When low is selected the alarm will initiate a low alarm on the output. When High is selected it will give a high alarm on the output.
- Alarm (3) Test = Used as a test to verify that the alarm circuit is functioning. When low is selected the alarm will initiate a low alarm on the output. When High is selected it will give a high alarm on the output.
- Reynolds Corr. = Reynolds number correction for the flow profile. Set to Enable for VIM20 insertion and set to Disable for VLM20 inline.
- Gain Control = Manual gain control (factory use only). Leave set at 1.
- Filter control = Manual filter control. This value can be changed to any number to force the fi value to a constant. A value of zero activates the automatic filter control which sets fi at a level that floats above the f value.
- High Pass Filter = Filter setting - Factory use only
- Factory Defaults = Reset factory defaults. If you change this to Yes and press Enter, all the factory configuration is lost and you must reconfigure the entire program. Consult the factory before performing this process, it is required only in very rare cases.

- Meter Type = Insertion (VIM20) or Inline (VLM20) meter.
- Config Code = Factory use only.
- Test Pulse Out = Force totalizer pulse. Set to Yes and press enter to send one pulse. Very useful to test totalizer counting equipment.
- Test Scaled Freq = Enter a frequency value in order to test the scaled frequency output. Return to 0 to stop the test.
- Output Type = Factory use only.
- Calibration Mode = Factory use only.
- A2D Ref. Resistor = Factory use only.
- Pressure Cal Current = Calibration value for the electronics and pressure transducer combination. Consult Factory for value.
- Pressure 9Cs = Nine pressure coefficients unique to the pressure transducer. Use the RIGHT ARROW to access all nine coefficients.
 - Press. Max psi = Based on installed sensor.
- Press. Min psi = 0 psi aRTD1. Press the RIGHT ARROW to access:
 - Ro = RTD resistance at 0 °C (1000 ohms).
 - A = RTD coefficient A (.0039083).
 - B = RTD coefficient B (-5.775e-07).
 - RTD1 Max Deg. F = 500
 - RTD1 Min Deg. F = -330
- RTD2 = Second RTD configuration, for special applications only.
- Correction Pairs
 - ft3/sec (1 through 10)
 - %Dev. (1 through 10)
- Roughness = Factory use only.
- Force Recal? = Factory use only.
- Min. Delta H - Energy EM meters only. Sets the deadband for totalization to begin. Must be greater than this number (1 default) to initiate the totalizer.
- Init Displ. (sec) = Enter a value in seconds to initialize the display every xxx seconds. Enter a value of 0 to disable initializing the display.

6.4 Analogue output calibration

To check the 4-20 mA circuit, connect a DVM in series with the output loop. Select zero or full scale (from the second column of the hidden diagnostics) and then actuate the enter key twice. This action will cause the meter to output its 4 mA or 20 mA conditions.

If the DVM indicates a current greater than ± 0.006 mA from 4 or 20, adjust the setting up or down until the output is calibrated.

Note: these settings are not for adjusting the output zero and span to match a flow range, that function is located in the Output Menu.

6.5 Troubleshooting the flowmeter



Warning!

Before attempting any flowmeter repair, verify that the line is not pressurized. Always remove main power before disassembling any part of the mass flowmeter. Use hazardous area precautions if applicable. Static sensitive electronics - use electro-static discharge precautions.

6.6 First check items:

- Installation direction correct
- Installation depth correct (insertion style meter)
- Power and wiring correct
- Application fluid correct
- Meter range correct for the application
- Meter configuration correct
- Describe Installation Geometry i.e. upstream diameters, valve position, downstream diameters, etc.

6.7 Record values:

Record the following values from the Run Menu with the meter installed in order to determine the operating state of the flowmeter:

	With Flow	With No Flow (if possible)
Flow =		
Temperature=		
Pressure =		
Density =		
Error Messages? =		

Record the following values from the Hidden Diagnostics Menu with the meter installed:

(Use password 16363 to access.)

	With Flow	With No Flow (if possible)
f =		
fi =		
A =		
A1 =		
A2 =		
A3 =		
A4 =		
V =		
RTD1 =		
RTD2 =		
Pe(V) =		
Pv(V) =		
Ck =		
Lvl =		
Adj. Filter =		
Iso. Power Volts =		
Sig. Rev =		

Record the following values from the Calibration Menu

Vortex Coef Ck =	
Low Flow Cutoff =	

6.8 Determine the fault

6.8.1 Symptom: output at no flow

1. The low flow cutoff is set too low. At no flow, go to the first level of the hidden diagnostics menu and record the Lvl value. The low flow cutoff must be set above this value.
2. Example: at no flow , Lvl = 25. Set the low flow cutoff in the Calibration Menu to approximately 28 and the meter will no longer read a flow rate at no flow.

6.8.2 Symptom: erratic output

1. The flow rate may be too low, just at the cutoff of the meter range, and the flow cycles above and below the cutoff making an erratic output. Consult the factory if necessary to confirm the meter range based on current operating conditions. It may be possible to lower the low flow cutoff to increase the meter range. See the example above for output at no flow, only this time the low flow cutoff is set too high. You can lower this value to increase the meter range as long as you do not create the output at no flow condition previously described.
2. Mechanical installation may be incorrect. Verify the straight run is adequate as described in Chapter 2. For in-line meters, make sure the meter is not installed backwards and there are no gaskets protruding into the flow stream. For insertion meters, verify the insertion depth and flow direction.
3. The meter may be reacting to actual changes in the flow stream. The output can be smoothed using a time constant.
The displayed values can be smoothed using the time constant in the Display Menu. The analog outputs can be smoothed using the time constant in the Output Menu. A time constant of 1 will result in the change in value reaching 63% of its final value in one second. A time constant of 4 is 22%, 10 is 9.5% and 50 is 1.9% of the final value in one second. The time constant equation is shown below (TC = Time Constant).

$$\% \text{ change to final value in one second} = 100 (1 - e^{-1/TC})$$

4. The vortex coefficient Ck may be incorrectly set. The Ck is a value in the equation used to determine if a frequency represents a valid vortex signal given the fluid density and signal amplitude. In practice, the Ck value controls the adaptive filter, fi, setting. During flow, view the f and fi values in the first level of the hidden diagnostics. The fi value should be approximately 10-20 % higher than the f value. If you raise the Ck setting in the Calibration Menu, then the fi value will increase. The fi is a low pass filter, so by increasing it or lowering it, you can alter the range of frequencies that the meter will accept. If the vortex signal is strong, the fi value will increase to a large number - this is correct.

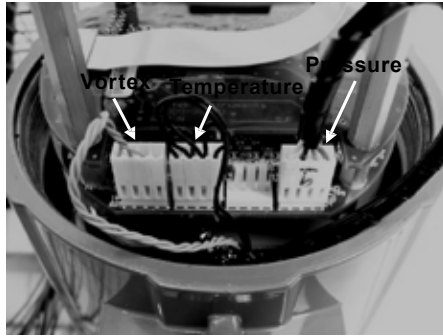

Fig. 59 Electronics stack sensor connections

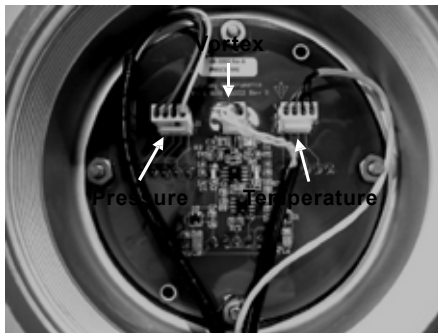

Fig. 60 Remote feed through board sensor connections

6.8.3 Symptom: no output

1. For remote mounted electronics, carefully check all the wiring connections in the remote mount junction box. There are 18 connections that must be correct, verify each color (black and red), shield, and wire number.

Turn on the pressure and temperature display in the Display Menu and verify that the pressure and temperature are correct.

Using ESD precautions and hazardous area precautions, remove the electronics enclosure window cover. Disconnect the vortex sensor from the electronics stack or remote feed through board. Refer to Figure 60 or 61. Measure the resistance from each outside pin to the meter ground should be open. Measure the resistance from the center pin to the meter ground - this should be grounded to the meter.

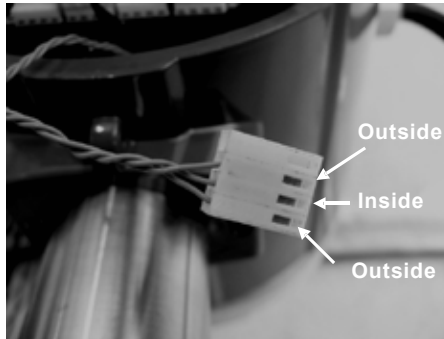

Fig. 61 Vortex Sensor Connector

With the sensor still disconnected, go to the first level of the hidden diagnostics and display the vortex shedding frequency, f . Hold a finger on the three exposed pins on the analog board. The meter should read electrical noise, 60 Hz for example. If all readings are correct, re-install vortex sensor wires.

4. Verify all meter configuration and troubleshooting steps previously described. There are many possible causes of this problem, consult factory if necessary

6.8.4 Symptom: meter displays temperature fault

1. For remote mounted electronics, carefully check all the wiring connections in the remote mount junction box. There are 18 connections that must be correct, verify each color (black and red), shield, and wire number.
2. Go to the first level of the hidden diagnostics and check the resistance of the rtd1. It should be about 1080 ohms at room temperature.
3. Using ESD precautions and hazardous area precautions, remove the electronics enclosure window cover. Disconnect the temperature sensor from the electronics stack or the remote feed through board. Refer to Figure 62 or 63. Measure the resistance across the outside pins of the temperature sensor connector. It should read approximately 1080 ohms at room temperature (higher resistance at higher temperatures).
4. Consult factory with findings

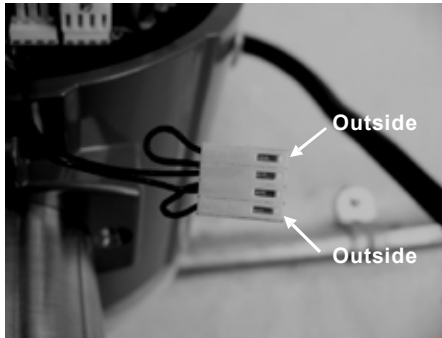

Fig. 62 Temperature Sensor Connector

6.8.5 Symptom: meter displays pressure fault

1. For remote mounted electronics, carefully check all the wiring connections in the remote mount junction box. There are 18 connections that must be correct, verify each color (black and red), shield, and wire number.
2. Using ESD precautions and hazardous area precautions, remove the electronics enclosure window cover. Disconnect the pressure sensor from the electronics stack or the remote feed through board. Measure the resistance across the outside pins of the pressure sensor connector, then across the inside pins. Both readings should be approximately 4000 ohms.

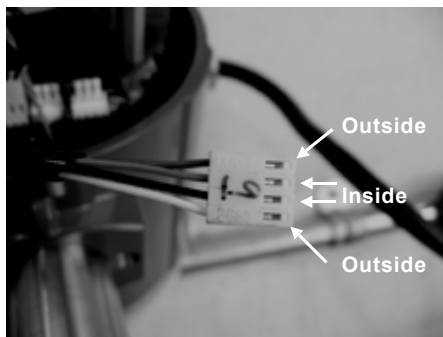

Fig. 63 Pressure Sensor Connector

3. Go to the first level of the hidden diagnostics and record the $P_e(V)$ and $P_v(V)$ values and consult the factory with findings

6.9 Electronics assembly replacement (all meters)



Warning!

Before attempting any flowmeter repair, verify that the line is not pressurized. Always remove main power before disassembling any part of the mass flowmeter.

The electronics boards are electrostatically sensitive. Wear a grounding wrist strap and make sure to observe proper handling precautions required for static-sensitive components.

1. Turn off power to the unit.
2. Locate and loosen the small set screw which locks the larger enclosure cover in place. Unscrew the cover to expose the electronics stack.
3. Locate the sensor harnesses which come up from the neck of the flowmeter and attaches to the circuit boards. Make note of the location of each sensor connection. Refer to Figures 59 and 60. The vortex sensor connection is on the left, the temperature sensor connection (if present) is second from the left, and the pressure sensor connection (if present) is the right most connector. Use small pliers to pull the sensor wiring connectors off of the circuit boards.
4. Locate and loosen the small set screw which locks the smaller enclosure cover in place. Unscrew the cover to expose the field wiring strip. Tag and remove the field wires.
5. Remove the screws that hold the black wiring label in place, remove the label.
6. Locate the 4 Phillips head screws which are spaced at 90° around the terminal board. These screws hold the electronics stack in the enclosure. Loosen these screws (Note: that these are captive screws, they will stay inside the enclosure).
7. Carefully remove the electronics stack from the opposite side of the enclosure. If the electronics stack will not come out, gently tap the terminal strip with the screw driver handle. This will loosen the rubber sealing gasket on the other side of the enclosure wall. Be careful that the stack does not hang up on the loose sensor harnesses.
8. Repeat steps 1 through 6 in reverse order to install the new electronics stack.

6.10 Pressure sensor replacement (VLM20 only)

1. For local mounted electronics, remove the electronics stack as previously described. For remote mount electronics, remove all wires and sensor connectors from the remote feed through board in the junction box at the meter.
2. Loosen the three set screws at the center of the adapter between the meter and the enclosure.
3. Remove the top half of the adapter to expose the pressure transducer.
4. Remove the transducer and replace it with the new one using appropriate thread sealant.
5. Reassemble in reverse order.

6.11 Returning equipment to the factory

Before returning any flowmeter to the factory, you must request a Return Material Authorization (RMA) number. To obtain an RMA number and the correct shipping address, contact Customer Service at:

Spirax Sarco Blythwood, S.C. 803-714-2000.

When contacting Customer Service, be sure to have the meter serial number and model code.

Please see the Meter Troubleshooting Checklist for additional items which may help with problem isolation. When requesting further troubleshooting guidance, please record the values on the checklist at no flow and during flow if possible.

7. Appendixes

7.1 Appendix A - Product specifications

7.1.1 Accuracy

Process Variables	VLM20 In-Line Meters		VIM20 Insertion Meters(1)	
	Liquids	Gas & Steam	Liquids	Gas & Steam
Mass Flow Rate	±1% of rate over a 30:1 range(3)	±1.5% of rate(2) over a 30:1 range(3)	±1.5% of rate over a 30:1 range(3)	±2% of rate(2) over a 30:1 range(3)
Volumetric Flow Rate	±0.7% of rate over a 30:1 range(3)	±1% of rate over a 30:1 range(3)	±1.2% of rate over a 30:1 range(3)	±1.5% of rate over a 30:1 range(3)
Temperature	± 2 °F (± 1 °C)	± 2 °F (± 1 °C)	± 2 °F (± 1 °C)	± 2 °F (± 1 °C)
Pressure	0.3% of transducer full scale	0.3% of transducer full scale	0.3% of transducer full scale	0.3% of transducer full scale
Density	0.3% of reading	0.5% of reading(2)	0.3% of reading	0.5% of reading(2)

Notes:

(1) Accuracies stated are for the total mass flow through the pipe.

(2) ver 50 to 100% of the pressure transducer's full scale.

(3) Nominal rangeability is stated. Precise rangeability depends on fluid and pipe size.

Repeatability

Mass Flow Rate: 0.2% of rate.

Volumetric Flow Rate: 0.1% of rate. Temperature: ± 0.2 °F (± 0.1 °C). Pressure: 0.05% of full scale.

Density: 0.1% of reading.

Stability Over 12 Months

Mass Flow Rate: 0.2% of rate maximum.

Volumetric Flow Rate: Negligible error. Temperature: ± 0.1 °F (± 0.5 °C) maximum. Pressure: 0.1% of full scale maximum.

Density: 0.1% of reading maximum.

Response Time

Adjustable from 1 to 100 seconds.

Material Capability

VLM20 In-Line Flowmeter: Any gas, liquid or steam compatible with 316L stainless steel or A105 carbon steel. Not recommended for multi-phase fluids.

VIM20 Vortex Insertion Flowmeter: Any gas, liquid or steam compatible with 316L stainless steel. Not recommended for multi-phase fluids.

Flow Rates

Typical mass flow ranges are given in the following table. Precise flow depends on the fluid and pipe size. VIM20 insertion meters are applicable to pipe sizes from DN50 (2") and above. Consult factory for sizing program.

Water minimum and maximum flowrates											
Process Connection	½"	¾"	1"	1.5"	2"	3"	4"	6"	8"	10"	12"
	15 mm	20 mm	25 mm	40 mm	50 mm	80 mm	100 mm	150 mm	200 mm	250 mm	300 mm
gpm Minimum	1	1.3	2.2	5.5	9.2	21	36	81	142	224	317
gpm Maximum	22	40	67	166	276	618	1076	2437	4270	6715	9501
m3/hr Minimum	0.23	0.3	0.5	1.3	2.1	4.7	8.1	18	32	51	72
m3/hr Maximum	5	9.1	15	38	63	140	244	554	970	1525	2158

VLM20 - Typical Metric flowrates

Saturated steam (kg/h)

Pressure		Nominal pipe size										
		15 mm	20 mm	25 mm	40 mm	50 mm	80 mm	100 mm	150 mm	200 mm	250 mm	300 mm
0 bar g	Min.	3	5	8	19	32	72	126	286	500	786	1113
	Max.	18	42	91	224	375	838	1459	3309	5797	9116	12898
5 bar g	Min.	6	11	18	45	75	167	290	658	1153	1813	2565
	Max.	95	224	485	1192	1992	4455	7754	17581	30799	48434	68530
10 bar g	Min.	8	15	24	59	99	222	387	877	1537	2417	3419
	Max.	168	397	862	2118	3539	7915	13777	31237	54720	86053	121758
15 bar g	Min.	9	17	29	71	119	266	463	1050	1840	2893	4094
	Max.	241	569	1236	3036	5073	11347	19750	44779	78444	123360	174543
20 bar g	Min.	11	20	33	81	136	304	529	1199	2100	3303	4673
	Max.	314	742	1610	3956	6611	14787	25738	58355	102226	160761	227463
30 bar g	Min.	13	24	40	99	165	369	642	1455	2548	4007	5669
	Max.	463	1092	2370	5822	9729	21763	37880	85884	150451	236599	334766

Air (nm³/h) at 20 °C

Pressure		Nominal pipe size										
		15 mm	20 mm	25 mm	40 mm	50 mm	80 mm	100 mm	150 mm	200 mm	250 mm	300 mm
0 bar g	Min.	3	5	9	21	36	79	138	313	549	863	1221
	Max.	28	66	142	350	584	1307	2275	5157	9034	14207	20102
5 bar g	Min.	7	13	21	52	87	194	337	764	1339	2105	2979
	Max.	165	390	847	2080	3476	7775	13533	30682	53749	84525	119596
10 bar g	Min.	9	17	29	70	117	262	457	1035	1814	2853	4036
	Max.	304	716	1554	3819	6381	14273	24844	56329	98676	155178	219563
15 bar g	Min.	11	21	34	85	142	317	551	1250	2190	3444	4873
	Max.	442	1044	2265	5565	9299	20801	36205	82087	143801	297386	319968
20 bar g	Min.	13	24	40	97	162	363	632	1434	2511	3949	5588
	Max.	582	1373	2979	7318	12229	27354	47612	107949	189105	297386	420775
30 bar g	Min.	16	29	48	118	198	442	770	1745	3057	4807	6801
	Max.	862	2034	4414	10843	18119	40529	70544	159942	280187	440621	623439

Linear Range

Smart electronics corrects for lower flow down to a Reynolds number of 5,000. The Reynolds number is calculated using the fluid's actual temperature and pressure monitored by the meter. Rangeability depends on the fluid, process connections and pipe size. Consult factory for your application. Typical velocity range ability in standard applications is as follows:

Liquids 30:1

0.30 metre per second velocity minimum 9.14 metre per second velocity maximum

Gases 30:1

3.05 metre per second velocity minimum 91.4 metre per second velocity maximum

VLM20 - Typical Imperial flowrates

Saturated steam (lb/h)

Pressure		Nominal pipe size										
		½"	¾"	1"	1½"	2"	3"	4"	6"	8"	10"	12"
5 psi g	Min.	6.5	12	20	49	82	183	318	722	1264	1988	2813
	Max.	52	122	265	650	1087	2431	4231	9594	16806	26429	37395
100 psi g	Min.	15	27	46	112	187	419	728	1652	2893	4550	6438
	Max.	271	639	1386	3405	5690	12729	22156	50233	87998	138386	195803
200 psi g	Min.	20	37	62	151	253	565	983	2229	3905	6141	8689
	Max.	493	1163	2525	6203	10365	23184	40354	91494	160279	252055	356635
300 psi g	Min.	24	45	74	182	304	680	1184	2685	4704	7397	10466
	Max.	716	1688	3664	9000	15040	33642	58556	132763	232575	365747	517499
400 psi g	Min.	28	51	85	209	349	780	1358	3079	5393	8481	12000
	Max.	941	2220	4816	11831	19770	44222	76971	174516	305717	480771	680247
500 psi g	Min.	31	57	95	233	389	870	1514	3433	6014	9457	13381
	Max.	1170	2760	5988	14711	24582	54987	95710	217001	380148	597812	845850

Air (SCFM) at 70 °F

Pressure		Nominal pipe size										
		½"	¾"	1"	1½"	2"	3"	4"	6"	8"	10"	12"
5 psi g	Min.	1.8	3	5	13	22	50	87	198	347	546	773
	Max.	18	41	90	221	369	826	1437	3258	5708	8976	12701
100 psi g	Min.	5	9	15	38	63	141	245	555	972	1529	2163
	Max.	138	325	704	1730	2890	6466	11254	25515	44698	70292	99456
200 psi g	Min.	7	13	21	52	86	193	335	761	1332	2059	2965
	Max.	258	609	1322	3248	5427	12140	21131	47911	83931	131895	186752
300 psi g	Min.	8	15	25	63	104	234	407	922	1615	2540	3594
	Max.	380	896	1944	4775	7978	17847	31064	70431	123375	19025	274529
400 psi g	Min.	10	18	29	72	120	269	467	1060	1857	2920	4132
	Max.	502	1183	2568	6309	10542	23580	41043	93057	163000	256358	362724
500 psi g	Min.	11	20	33	80	134	300	521	1182	2071	3257	4608
	Max.	624	1472	3195	7849	13115	28034	51063	115775	203000	318941	451272

Linear Range

Smart electronics corrects for lower flow down to a Reynolds number of 5,000. The Reynolds number is calculated using the fluid's actual temperature and pressure monitored by the meter. Rangeability depends on the fluid, process connections and pipe size. Consult factory for your application. Typical velocity range ability in standard applications is as follows:

Liquids 30:1

1 foot per second velocity minimum 30 feet per second velocity maximum

Gases 30:1

10 feet per second velocity minimum 300 feet per second velocity maximum

VIM20 - Typical Metric flowrates

Saturated steam (kg/h)

Pressure		Nominal pipe size					
		80 mm	150 mm	200 mm	300 mm	400 mm	600 mm
0 bar g	Min.	81	316	548	1226	1936	4404
	Max.	938	3667	6350	14209	22432	51039
5 bar g	Min.	187	729	1263	2826	4461	10151
	Max.	4986	19486	33742	75495	119189	271187
10 bar g	Min.	249	972	1683	3767	5947	13530
	Max.	8859	34620	59949	134132	211764	481821
15 bar g	Min.	298	1164	2016	4510	7120	16200
	Max.	12700	49629	85939	192283	303570	690705
20 bar g	Min.	340	1329	2301	5148	8128	18493
	Max.	16550	64676	111995	250581	395609	900119
30 bar g	Min.	413	1612	2791	6246	9860	22435
	Max.	24357	95187	164827	368789	582234	1324739

Air (nm³/h) at 20 °C

Pressure		Nominal pipe size					
		80 mm	150 mm	200 mm	300 mm	400 mm	600 mm
0 bar g	Min.	89	347	601	1345	2124	4833
	Max.	1463	5716	9897	22145	34962	79547
5 bar g	Min.	217	847	1467	3282	5181	11788
	Max.	8702	34006	58885	131751	208004	473266
10 bar g	Min.	294	1148	1987	4446	7020	15972
	Max.	15975	62430	108105	241878	381870	868857
15 bar g	Min.	355	1385	2399	5368	8474	19282
	Max.	23280	90979	157542	352487	556497	1266182
20 bar g	Min.	407	1589	2751	6156	9718	22112
	Max.	30615	119642	207175	463539	731823	1665095
30 bar g	Min.	495	1934	3349	7493	11829	26915
	Max.	45361	177268	306961	686801	1084302	2467081

Linear Range

Smart electronics corrects for lower flow down to a Reynolds number of 5,000. The Reynolds number is calculated using the fluid's actual temperature and pressure monitored by the meter. Rangeability depends on the fluid, process connections and pipe size. Consult factory for your application. Typical velocity range ability in standard applications is as follows:

Liquids 30:1

0.30 metre per second velocity minimum

9.14 metre per second velocity maximum

Gases 30:1

3.05 metre per second velocity minimum

91.4 metre per second velocity maximum

VIM20 - Typical Imperial flowrates

Saturated steam (lb/h)

Pressure		Nominal pipe size					
		3"	6"	8"	12"	16"	24"
5 psi g	Min.	205	800	1385	3099	4893	11132
	Max.	2721	10633	18412	41196	65039	147954
100 psi g	Min.	468	1831	3170	7092	11197	25472
	Max.	14246	55674	96407	215703	340546	774698
200 psi g	Min.	632	2471	4278	9572	15111	34377
	Max.	25948	101405	175595	392880	620268	1411029
300 psi g	Min.	762	2976	5153	11530	18203	41410
	Max.	37652	147145	254799	570093	900047	2047489
400 psi g	Min.	873	3412	5908	13219	20870	47477
	Max.	49494	193420	334930	749382	1183103	2691404
500 psi g	Min.	974	3805	6588	14741	23272	52942
	Max.	61543	240507	416468	931816	1471125	3346615

Air (SCFM) at 70 °F

Pressure		Nominal pipe size					
		3"	6"	8"	12"	16"	24"
5 psi g	Min.	56	220	381	852	1345	3059
	Max.	924	3611	6253	13991	22089	50250
100 psi g	Min.	157	615	1065	2383	3763	8560
	Max.	7236	28279	48969	109564	172977	393500
200 psi g	Min.	216	843	1460	3266	5156	11729
	Max.	13588	53101	91950	205732	324804	738886
300 psi g	Min.	262	1022	1770	3960	6251	14221
	Max.	19974	78059	135169	302430	477467	1086176
400 psi g	Min.	301	1175	2034	4551	7186	16346
	Max.	26391	103136	178593	399588	630859	1435121
500 psi g	Min.	335	1310	2269	5077	8015	18233
	Max.	32834	128314	222191	497136	784865	1785464

Linear Range

Smart electronics corrects for lower flow down to a Reynolds number of 5,000. The Reynolds number is calculated using the fluid's actual temperature and pressure monitored by the meter. Rangeability depends on the fluid, process connections and pipe size. Consult factory for your application. Typical velocity range ability in standard applications is as follows:

Liquids 30:1

1 foot per second velocity minimum 30 feet per second velocity maximum

Gases 30:1

10 feet per second velocity minimum 300 feet per second velocity maximum

7.1.2 Process fluid pressure

VLM20 Pressure Ratings		
Process connection	Material	Rating
Flanged	316L SS, A105 Carbon Steel	150, 300, 600 lb, PN40, PN100
Wafer	316L SS, A105 Carbon Steel	600 lb, PN64

VIM20 Pressure Ratings		
Probe Seal	Process Connection	Rating
Compression fitting	2" Male NPT	ASME 600 lb
	2" 150 lb flange, DN50 PN16	ANSI 150 lb, PN16
	2" 300 lb flange, DN50 PN40	ANSI 300 lb, PN40
	2" 600 lb flange, DN50 PN63	ANSI 600 lb, PN63
Packing gland	2" Male NPT	ASME 300 lb
	2" 150 lb flange, DN50 PN16	ANSI 150 lb, PN16
	2" 300 lb flange, DN50 PN40	ANSI 300 lb, PN40
Packing gland and permanent retractor	2" Male NPT	ASME 600 lb
	2" 150 lb flange, DN50 PN16	ANSI 150 lb, PN16
	2" 300 lb flange, DN50 PN40	ANSI 300 lb, PN40
	2" 600 lb flange, DN50 PN63	ANSI 600 lb, PN63

7.1.3 Pressure transducer ranges

Pressure sensor ranges(1) , psi a (bar a)			
Full scale operating pressure		Maximum Over-Range Pressure	
psi a	(bar a)	psi a	(bar a)
30	2	60	4
100	7	200	14
300	20	600	41
500	34	1000	69
1500	100	2500	175

Note:

(1) To maximize accuracy, specify the lowest full scale operating pressure range for the application. To avoid damage, the flowmeter must never be subjected to pressure above the over-range pressure shown above.

12 to 36 Vdc, 25 mA, 1 W max., Loop Powered Volumetric or Mass
 12 to 36 Vdc, 300 mA, 9 W max. Multiparameter Mass options
 100 to 240 VAC, 50/60 Hz, 5 W max. Multiparameter Mass options
 Class I Equipment (Grounded Type)

Power

requirements

Installation (Over-voltage) Category II for transient over-voltages
 ac & dc Mains supply voltage fluctuations are not to exceed +/-10% of the rated supply voltage range.
 User is responsible for the provision of an external Disconnect Means (and Over-Current Protection) for the equipment (both ac and dc models).

Display

Alphanumeric 2 x 16 LCD digital display.
 Six push-button switches (up, down, right, left, enter, exit) operable through explosion-proof window using hand-held magnet.
 Viewing at 90-degree mounting intervals.



Process fluid and ambient temperature

Process fluid:
 Standard temperature sensor: -200 to 260 °C (-330 to 500 °F)
 High temperature sensor: 260 to 400 °C (500 to 750 °F)
Ambient:
 Operating temperature range: -40 to 60 °C (-40 to 140 °F)
 Storage temperature range: -40 to 85 °C (-40 to 185 °F)
 Maximum relative humidity: 0-98%, non-condensing conditions
 Maximum altitude: 2,000 meters (6,560 feet)
 Pollution Degree 2 for the ambient environment

Enclosure

protection classification

NEMA 4X and IP66 cast enclosure.

Output signals (1)	<p>Analogue: Volumetric Meter: field rangeable linear 4-20 mA output signal (1200 Ohms maximum loop resistance) selected by user for mass flow rate or volumetric flow rate.</p> <p>Communications: HART, MODBUS, RS485</p> <p>Multiparameter Meter: up to three field rangeable linear 4-20 mA output signals (1200 Ohms maximum loop resistance) selected from the five parameters-mass flow rate, volumetric flow rate, temperature, pressure and density.</p> <p>Pulse:Pulse output for totalization is a 50-millisecond duration pulse operating a solid-state relay capable of switching 40 Vdc, 40 mA maximum.</p> <p>Note: (1) All outputs are optically isolated and require external power for operation.</p>				
Alarms	Up to three programmable solid-state relays for high, low or window alarms capable of switching 40 Vdc, 40 mA maximum.				
Totalizer	Based on user-determined flow units, six significant figures in scientific notation. Total stored in non-volatile memory.				
Wetted materials	<p>VLM20 In-Line Flowmeter: 316L stainless steel standard. C276 hastelloy or A105 carbon steel optional.</p> <p>VIM20 Vortex Insertion Flowmeter: 316L stainless steel standard. Teflon® packing gland below 260 °C (500 °F). Graphite packing gland above 260 °C (500 °F).</p>				
Electrical ports	<p>Series VLM20 In-Line Flowmeter:</p> <p>Non  marked versions Two ¾" female NPT ports.</p> <p> marked versions Two M20 female ports.</p> <p>Series VIM20 Vortex Insertion Flowmeter:</p> <p>Two ¾" female NPT ports.</p>				
Mounting connections	<p>VLM20: Wafer, 150, 300, 600 lb ANSI flange, PN40, PN100 flange.</p> <p>VIM20 Permanent installation: 2" MNPT; 150, 300, 600 lb ANSI flange, PN16, PN40, PN64 flange with compression fitting probe seal.</p> <p>VIM20 Hot Tap(1) Installation: 2" MNPT; 150, 300, 600 lb ANSI flange, PN16, PN40, PN64 flange and optional retractor with packing gland probe seal.</p> <p>Note: (1) Removable under line pressure.</p>				
Mounting position	<p>Series VLM20 In-Line Flowmeter: No effect.</p> <p>Series VIM20 Vortex Insertion Flowmeter: Meter must be perpendicular within ± 5° of the pipe centerline.</p>				
Certifications	<table border="0"> <tr> <td data-bbox="269 1342 667 1390">Material Certificate - US Mill certs on all wetted parts</td> <td data-bbox="706 1342 1003 1390">Certificate of Conformance</td> </tr> <tr> <td data-bbox="269 1390 516 1422">Pressure Test Certificate</td> <td data-bbox="706 1366 1003 1422">NACE Certification (MR0175) Oxygen Cleaning (CGA G-4).</td> </tr> </table>	Material Certificate - US Mill certs on all wetted parts	Certificate of Conformance	Pressure Test Certificate	NACE Certification (MR0175) Oxygen Cleaning (CGA G-4).
Material Certificate - US Mill certs on all wetted parts	Certificate of Conformance				
Pressure Test Certificate	NACE Certification (MR0175) Oxygen Cleaning (CGA G-4).				
Conformity	 marked only				

7.2 Appendix B Approvals

Low Voltage Directive

Directive 2014/35/EU

EN 61010-1:2010

Electromagnetic Compatibility Directive

Directive 2014/30/EU

EN 61000-6-2:2005

EN 55011:2009 + A1:2010 Group 1 Class A



7.3 Appendix C flowmeter calculations

7.3.1 In-line flowmeter calculations

Flowing velocity

$$Q_v = \frac{f}{K}$$

Volume flowrate

$$Q_M = Q_v P$$

Mass flowrate

$$V_f = \frac{QV}{A}$$

Where:

A = Cross sectional area of the pipe (ft²)

f = Vortex shedding frequency (pulses / sec)

K = Meter factor corrected for thermal expansion (pulses / ft³)

Q_M = Mass flow rate (lb / sec)

Q_v = Volume flow rate (ft³ / sec)

V_f = Flowing velocity (ft / sec)

r = Density (lb / ft³)

7.3.2 Insertion flowmeter calculations

Flowing velocity

$$V_f = \frac{f}{K_C}$$

Volume flowrate

$$Q_v = V_f A$$

Mass flowrate

$$Q_M = V_f A \rho$$

Where:

A = Cross sectional area of the pipe (ft²)

f = Turbine meter frequency (pulses / sec)

K_C = Meter factor corrected for Reynolds Number (pulses / ft)

Q_v = Volume flowrate (ft³ / sec)

Q_M = Mass flowrate (lb / sec)

V_f = Flowing velocity (ft / sec)

ρ = Density (lb / ft³)

7.3.3 Fluid calculations

Calculations for Steam T & P

When "Steam T & P" is selected in the "Real Gas" selection of the Fluid Menu, the calculations are based on the equations below.

Density

The density of steam is calculated from the formula given by Keenan and Keys. The given equation is for the volume of the steam.

$$v = \frac{4.555.04 \cdot T}{\rho} + B$$

$$B = B_0 + B_0^2 g_1(\tau) \tau \cdot \rho + B_0^4 g_2(\tau) \tau^3 \cdot \rho^3 - B_0^{13} g_3(\tau) \tau^{12} \cdot \rho^{12}$$

$$B_0 = 1.89 - 2641.62 \cdot \tau \cdot 10^{80870r^2}$$

$$g_1(\tau) = 82.546 \cdot \tau - 1.6246 \cdot 10^5 \cdot \tau^2$$

$$g_2(\tau) = 0.21828 - 1.2697 \cdot 10^5 \cdot \tau^2$$

$$g_3(\tau) = 3.635 \cdot 10^{-4} - 6.768 \cdot 10^{64} \cdot \tau^{24}$$

Where tau is 1/ temperature in Kelvin.

The density can be found from 1/(v/ standard density of water).

Viscosity

The viscosity is based on an equation given by Keenan and Keys.

$$\eta(\text{poise}) = \frac{1.501 \cdot 10^{-5} \sqrt{T}}{1 + 446.8 / T}$$

Where T is the temperature in Kelvin

7.3.4 Calculations for Gas ("Real Gas" and "Other Gas")

Use this formula to determine the settings for "Real Gas; Gas" selections and "Other Gas" selections entered in the Fluid Menu. The calculations for gas were taken from Richard W. Miller, Flow Measurement Engineering Handbook (Third Edition, 1996).

Density

The density for real gases is calculated from the equation:

$$\rho = \frac{GM_{w, Air} P_f}{Z_f R_0 T_f}$$

Where G is the specific gravity, M_w is the molecular weight of air, p_f is the flowing pressure, Z is flowing compressibility, R_0 is the universal gas constant, and T is the flowing temperature. The specific gravity, and R_0 are known and are stored in a table used by the Turbine meter. The hard coefficient to find is the compressibility, Z. Z is found using the Redlich-Kwong Equation (Miller page 2-18).

The Redlich-Kwong Equation uses the reduced temperature and pressure to calculate the compressibility factor. The equations are non linear and an iterative solution is used. The Turbine program uses Newton's Method on the Redlich-Kwong equations to iteratively find the compressibility factor. The critical temperature and pressure used in the Redlich-Kwong equation are stored in the fluid data table with the other coefficients.

Viscosity

The viscosity for real gases is calculated using the exponential equation for two known viscosities. The equation is:

$$\mu_{cP} = aT_{Kn}$$

Where a and n are found from two known viscosities at two temperatures.

$$n = \frac{\ln [(\mu_{cP})_2 / (\mu_{cP})_1]}{\ln(T_{K2} / T_{K1})}$$

and

$$a = \frac{(\mu_{cP})_1}{T_{K1}^n}$$

7.3.5 Calculations for liquid

Use this formula to determine the settings for "Goyal-Dorais" selections and "Other Liquid" selections entered in the Fluid Menu. The liquid calculations were taken from Richard W. Miller, Flow Measurement Engineering Handbook (Third Edition, 1996).

Density

The liquid density is found using the Goyal-Doraiswamy Equation.

Goyal-Doraiswamy uses the critical compressibility, critical pressure and critical temperature, along with the molecular weight to find the density.

The equation for specific gravity is:

$$G_F = \frac{p_c Mw}{T_c} \left(\frac{0.008}{Z_c^{0.773}} - 0.01102 \frac{T_f}{T_c} \right)$$

The specific gravity can then be converted into density.

Viscosity

The liquid viscosity is found by Andrade's equation. This uses two viscosities at different temperatures to extrapolate the viscosity.

Andrade's equation:

$$\mu = A_L \exp \frac{B_L}{T_{deg R}}$$

To find A and B

$$B_L = \frac{T_{deg R1} T_{deg R2} \ln(\mu_1 / \mu_2)}{T_{deg R1} - T_{deg R2}}$$

$$A_L = \frac{\mu_1}{\exp(B_L / T_{deg R1})}$$

The temperatures are all in degrees Rankin. Do not believe the subscript R means they are reduced temperatures.

7.4 Appendix D glossary

	A	Cross sectional area.
A	ACFM	Actual Cubic Feet Per Minute (volumetric flowrate).
	ASME	American Society of Mechanical Engineers.
B	BTU	British Thermal Unit, an energy measurement.
C	Cenelec	European Electrical Code.
	Compressibility factor	A factor used to correct for the non-ideal changes in a fluid is density due to changes in temperature and/or pressure.
	CSA	Canadian Standards Association.
D	D	Diameter of a flow channel.
	f	Frequency generated by a turbine flowmeter, usually in Hz.
	Flow channel	A pipe, duct, stack, or channel containing flowing fluid.
	Flow profile	A map of the fluid velocity vector (usually non- uniform) in a cross-sectional plane of a flow channel (usually along a diameter).
F	FM	Factory Mutual.
	Ft	Foot, a measure of length.
	Ft²	Square feet, measure of area.
	Ft³	Cubic feet, measure of volume.
G	GPM	Gallons Per Minute.
H	Hz	Hertz, cycles per second.

I	Insertion flowmeter	A flowmeter which is inserted into a hole in the user's pipeline.
J	Joule	A unit of energy equal to one watt for one second. Also equal to a Newton meter.
L	LCD	Liquid crystal display.
M	\dot{m}	Mass flowrate.
	mA	Milli-amp, one thousandth of an ampere of current.
	μ	Viscosity, a measure of a fluid's resistance to shear stress. Honey has high viscosity, alcohol has low viscosity.
P	ΔP	Permanent pressure loss.
	P	Line pressure (psi a or bar absolute).
	ρ_{act}	The density of a fluid at the actual temperature and pressure operating conditions.
	ρ_{std}	The density of a fluid at standard conditions (usually 14.7 psi a and 20 °C).
	Permanent	Unrecoverable drop in pressure. Pressure Loss
	Pitch	The angle of the blades of a turbine rotor.
	PRTD	An resistance temperature detector (RTD) with platinum as its element. Used because of high stability.
	psi a	Pounds per square" absolute (equals psi g + atmospheric pressure). Atmospheric pressure is typically 14.696 psi at sea level.
	psi g	Pounds per square inch gauge.
	PV	Liquid vapor pressure at flowing conditions (psi a or bar absolute).

Q	Q	Flowrate, usually volumetric.
R	Rangeability	Highest measurable flowrate divided by the lowest measurable flowrate.
	Reynolds number	A dimensionless number equal to the density of a fluid or Retimes the velocity of the fluid times the diameter of the fluid channel, divided by the fluid viscosity (i.e., $Re = \rho VD/\mu$). The Reynolds number is an important number for turbine flowmeters because it is used to determine the minimum measurable flowrate. It is the ratio of the inertial forces to the viscous forces in a flowing fluid.
	Rotor	The velocity sensing element of a turbine flowmeter. Rotors are manufactured with the blades at a certain pitch. The pitch of the rotor blades determine the maximum velocity the turbine flowmeter can be used in.
	RTD	Resistance temperature detector, a sensor whose resistance increases as the temperature rises.
S	scfm	Standard cubic feet per minute (flowrate converted to standard conditions, usually 14.696 psi a and 68 °F).
T	Totalizer	An electronic counter which records the total accumulated flow over a certain range of time.
	Traverse	The act of moving a measuring point across the width of a flow channel.
U	Uncertainty	The closeness of agreement between the result of a measurement and the true value of the measurement.
	V	Velocity or voltage.
V	Vac	Volts, alternating current.
	Vdc	Volts, direct current.

