

Colima Visco and Colima Viscorol Magnetic Level Indicators

Installation and Maintenance Instructions

**Colima
Visco**

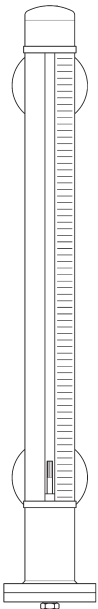

**Colima
Viscorol**

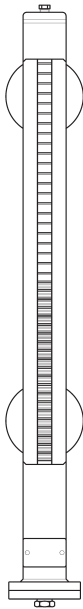

**Colima
Viscorol PH**

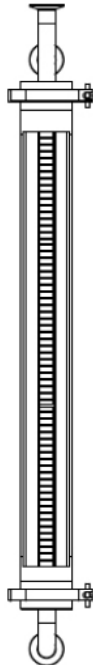

1. Safety information
2. General product information
3. Installation and Maintenance
4. Accessories
5. Grounding
6. Spare parts

1. Safety information

1.1 Type of application

The suitability of the Colima Visco and Colima Viscorol has to be verified for the specific usage and application according to the product name-plate, technical specifications and to these Installation and Maintenance instructions.

The Colima Visco and Colima Viscorol comply with the requirements of the following European Directives: 2014/68/EU (PED) and 2014/34/EU (ATEX) (for the electric equipment only).

1.2 Accessibility

Ensure safe access and, where necessary, a safe and correctly protected platform before working on the product. Use suitable lifting mechanisms where required.

1.3 Lighting

Ensure adequate lighting, particularly where detailed or intricate work is required.

1.4 Hazardous gases or liquids in the pipeline

Consider the present or previous content of the pipeline paying attention to inflammable materials, substances dangerous to health and to extremes of temperature.

1.5 Dangerous environment

Take account of areas at risk of explosion, lack of oxygen (e.g. tanks or pits), dangerous gases, temperature extremes, hot surfaces, fire hazard (e.g. during welding), excessive noise, moving machinery.

1.6 The system

Consider the effect on the complete system of the work proposed. Will any proposed action (e.g. closing isolation valves, electrical isolation) put any other part of the system or any personnel at risk? Dangers might include isolation of vents or protective devices or the rendering ineffective of controls or alarms. Ensure isolation valves are turned on and off in a gradual way to avoid system shocks.

1.7 Pressure

Ensure that all parts exposed to pressure are isolated or adequately vented to atmospheric pressure. Do not assume a system is de-pressurized even when the pressure gauge reads zero.

1.8 Temperature

To avoid the risk of burns, wait until the unit has reached ambient temperature before handling after isolation.

1.9 Tools and consumables

Before starting a work, ensure the availability of appropriate tools and / or consumables. Only use the spare parts listed in Section 5.

1.10 Protective clothing

Consider whether you and/or other personnel need protective clothing, against for example chemical products, high or low temperatures, noise, falling objects and hazards to eyes and face.

1.11 Other risks

During normal operation the product surface could be very hot. The surface temperature of some products operating at the maximum allowable temperature may reach 350°C.

Please take this information into account before disassembly or removal from the plant!

1.12 Freezing

The Colima Visco and Colima Viscorol are non auto-drainage products. Where they are exposed to temperatures below zero they must be protected from the damage caused by freezing conditions.

1.13 Disposal

Unless otherwise stated within these Installation and Maintenance Instructions, these products are recyclable. Therefore, provided appropriate precaution is taken, there is no potential ecological risk after their disposal.

1.14 Returning products

According to European Community laws on Health, Safety and Environmental Protection, upon returning products for their testing and/or repairs to Spirax Sarco, customers and distributors are reminded that they must supply the necessary information on hazards and precautions to be taken with regard to the presence of contaminated product residues or instrument damage which may present a health and/or environmental safety hazard.

2. General product information

2.1 Description

Colima Visco and Colima Viscorol magnetic level indicators have been designed for optical viewing of liquid levels in most industrial applications. They are suitable for high pressure and high temperature applications and the range is complemented by having a pharmaceutical grade option available when requested.

The indicators can be equipped with electrical contacts or with a potentiometer transmitter for full automation of process management, including pressurised tanks, vats, boilers, for the control of pumps, valves and alarm systems.

Mounting - The Colima Visco and Colima Viscorol magnetic level indicators are installed on the side of the tank (bypass system) or vertically on the top of the tank.

Optional extras - Electrical bistable reed switch contacts, placed at the required levels; thus allowing control of several operating points with a single instrument.

When equipped with a potentiometer transmitter, they allow continuous reading of liquid level.

Standards and certification - Colima Visco and Colima Viscorol magnetic level indicators comply with the following regulations and European Directives:

- PED 2014/68/EU - up to Class IV (plastic materials excluded)
- ATEX 2014/34/EU (for explosion proof area's application)
- 2014/30/EU Electromagnetic compatibility
- 2014/35/EU Low tension, for electrical components only
- DNV, RINA, LRS and M.M.I. for naval/marine sectors
- Conformity declaration EC1935
- Conformity declaration DM174

Remark: any request of inspection and/or certification shall be defined in phase of order.

2.1.1 Operation

The indicator's body houses a float which rises or falls following the level of the liquid in a vessel. The float is provided with a magnetic system that attracts the two-colour rollers (Colima Viscorol) or a two-colour indicator (Colima Visco) vertically aligned in a transparent tube sealed at both ends. The tube stands vertically outside the indicator's body and is retained by a scale.

Colima Visco - The line between red and white marks the level of liquid in the tank.

Colima Viscorol - When the tank is empty all the rollers have the white side facing the observer. As the level of the float rises the rollers are actuated magnetically, they rotate through 180° to show their red side. The line between red and white marks the level of liquid in a vessel.

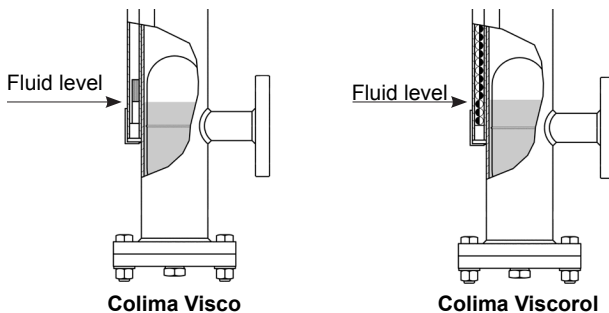

Warning

The correct selection of the diameter of the indicator body and the connection rating must always relate to the specific installation and application conditions.

2.2 Materials

No.	Part	Material
1	Vertical chamber	304 / 316L / 316Ti / PVC / PP / PVDF 316 Ti no R25 and Viscorol 40 316L for Viscorol PH
2	Scale	Neutral or graduated with the exception of R25 and 40
3	Glass tube	Polycarbonate or Pyrex
4	Bicolour indicator	Plastic or Alnico
5	Bicolour rolling cylinders	Plastic or Aluminium
6	Float (not shown)	316L / 316Ti / Titanium / Hastelloy PVC / PP / PVDF 316L for Viscorol PH

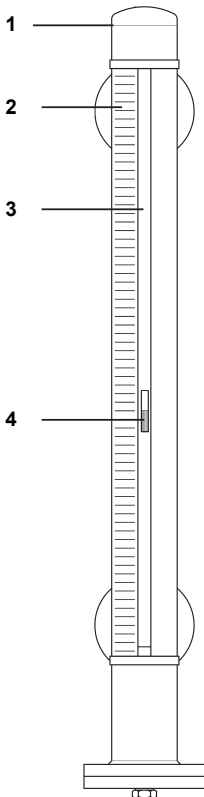

**Colima
Visco**

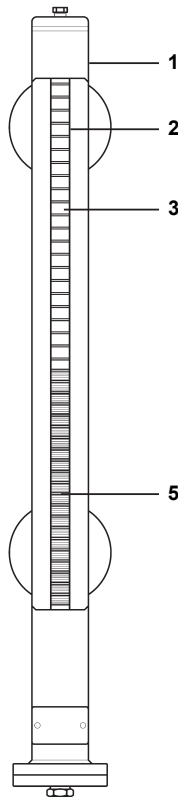

**Colima
Viscorol**

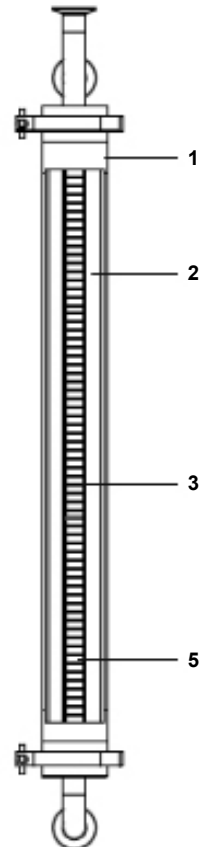

**Colima
Viscorol PH**

2.3 Design limits - Colima Visco and Colima Viscorol

TMA - Maximum allowable temperature	Steel	Ø 40	-25 to	+180°C	
		Ø 50-60-70	-25 to	+350°C	
	Plastic	Viscorol 70 PH		-25 to	+191,7°C
		PVC		-20 to	+70°C
		PP		-20 to	+105°C
		PVDF		-20 to	+130°C
PMA - Maximum allowable pressure	Steel	120 bar g		350°C	
		140 bar g		150°C	
	Viscorol 70 PH	7 bar @		191,7°C	
		10 bar @		184,1°C	
	Plastic		< 6 bar g		
Specific gravity of fluid	Steel and plastic			> 0.8 kg/l	
	Titanium			> 0.5 kg/l	
Two-colour line marker material and rollers	Polycarbonate			T < 230°C	
	Aluminium			T < 350°C	
Protection degree graduated scale	Viscorol			IP67	
	Visco			IP40	

3. Installation and Maintenance

Note: Before actioning any installation or maintenance work observe the 'Safety information' in Section 1.

Referring to the Installation and Maintenance Instructions, name-plate and Technical Information Sheet, check that the product is suitable for the intended installation.

- Check materials, pressure and temperature to ensure compatibility of the product with the required application.
- Remove protective covers from all connections and the protective film from the name-plate.

3.1 Assembly

The Colima Visco and Colima Viscorol magnetic level indicators are delivered with the float packed and locked at its lower flange.

Caution before installation disassemble the lower flange and remove the float from its package.

Confirm the presence of supplied gaskets.

3.1.1

Insert the float inside the indicator body following the direction arrow: ' → ' and 'TOP'.

3.1.2

Reassemble the lower flange, and tighten the bolts.

3.1.3

Mount the level indicator onto the tank; ensuring that all connections are aligned and tighten.

Note: we recommend that isolation valves are installed between the tank and the indicator connections to facilitate quicker and safer product removal.

3.1.4

lowly fill the tank allowing the float to become buoyant.

3.1.5

Ensure that there is no particulate matter suspended in the fluid that may affect the float's movement.

3.1.6

In order to improve its visibility, it is also possible to rotate the visual scale around the axis of the indicator.

Executing this action (by acting on the metallic fixing clamps), be careful not to move longitudinally the graduated scale, as this may result in incorrect level readings.

Caution: in presence of electrical contacts mounted on an adjustment rod, these electrical contacts should also be rotated respecting the same angle and rotation direction provided by the visual scale.

3.2 Disassembly

Before disassembly of the level indicator disconnect or isolate any electricity supply or circuit and depressurize the tank. Warning: do not disassemble the level switch before the isolation valves have been closed or tank emptied.

3.2.1

Close isolation valves or empty the tank. Ensure that isolation valves cannot be opened when the level indicator has been removed.

3.2.2

Unscrew thread or connection bolts.

3.2.3

Disassemble the level indicator from the tank connections.

Caution: support the float during the disassembly ensuring that it does not drop and hit the base of the body. Avoid any accidental damage to the body, scale or float.

Periodical inspections are necessary to guarantee complete efficiency of the instrument. A regular maintenance programme starting from its initial installation is recommended. The suggested precautions are important to obtain the best operating conditions of the level control.

The instrument does not require preventative maintenance, however it is recommended that from time-to-time a check of the liquid fluidity is actioned to avoid any suspensions or deposits that can influence wetted parts. Some versions are provided with a drain hole. Also check that the float moves freely and check the serviceability of the rollers/indicator.

Models:



Colima Visco and Colima Viscorol LL

Side / side connections to vessel.
All wetted parts made of Stainless Steel or Plastic material.



Colima Visco and Colima Viscorol LF

Side / bottom connections.
All wetted parts made of Stainless Steel or Plastic material.



Colima Visco and Colima Viscorol LT

Top / side connections.
All wetted parts made of Stainless Steel or Plastic material.



Colima Visco and Colima Viscorol TF

Axial connections.
All wetted parts made of Stainless Steel or Plastic material.



Colima Visco and Colima Viscorol R

Top connection with immersed float.
Recommended model for tanks or vessels in areas difficult to access and in case of particularly viscous fluids, covering fluids, sludges.
All wetted parts made of Stainless Steel or Plastic material.

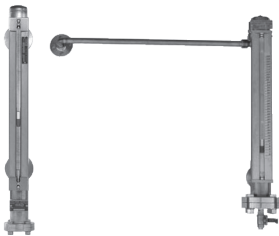

Colima Visco GV and GDV

Side / side connections.
All wetted parts made of Stainless Steel.
Specifically designed to control methane-gas odorant.



Colima Viscorol PH

Side / side connections (see figure).
All wetted parts are made of Stainless Steel.
Specifically designed for the pharmaceutical market.

4. Accessories

For a complete automated management of barrels (even under pressure), tanks, boilers, and for the control of pumps, valves and alarm systems, Visco and Viscorol Magnetic Level Indicators may be equipped with electrical contacts and with potentiometric transmitter.

4.1 Electric contacts

Limit switches are fitted onto the of the indicator tube, and positioned behind the visual scale. They must be installed at the intervention point required for the automated level control.

As the level of liquid reaches the expected level, the magnetic system fitted inside the float activates the contacts. When the liquid level returns to the required band the contact switches, maintaining the state even beyond the threshold itself. The contact will be restored only when the float passes in the opposite direction.

The status switch for each contact always takes place quickly and safely. Parameter settings are factory-defined at the required set- points, however they are adjustable as needed. With a single device it is possible to control multiple levels.

4.1.1 Contact features

Contacts can be SPDT and DPDT (two SPDT contacts with simultaneous action) running bistable.

Type	Reed switch contact.
	Hermetically sealed in inert gas.
	Tungsten coated Rhodio.
	60 W/VA 1A 250 V ≡
	Shock and vibration resistance 30g 11ms
	Maximum allowable temperature -20°C +200°C

4.1.2 Electrical connection of the contacts

Note: always perform the ground connection.

Colima Visco

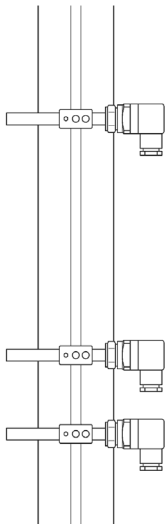

In order to control the rising up fluid, electrical contacts wiring shall be as follows:

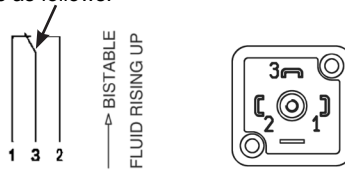

In order to control the falling down fluid, electrical contacts wiring shall be as follows:

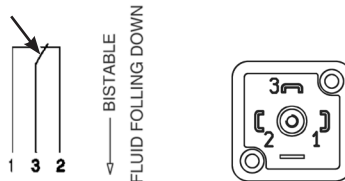

Contact position: 90° respect to the visual indicating scale.

Colima Viscorol

DPDT bistable reed switch contact (two SPDT contacts alongside each other). The position of the contacts is always field adjustable

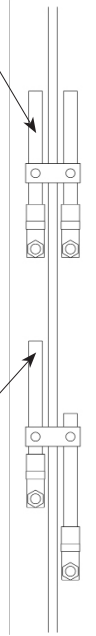

In order to control the rising up fluid, electrical contacts wiring shall be as follows:



↑ BISTABLE
FLUID RISING UP



In order to control the falling down fluid, electrical wiring contacts wiring shall be as follows:



↓ BISTABLE
FLUID FOLLING DOWN



SPDT bistable reed switch contact. The position of the contact is always field adjustable

Contact position: 180° respect to the visual indicating scale

Warning

Electric contacts can be damaged by the following:

- Installation accidental damage.
- Over supply of voltage.
- Electromagnetic interference.

Before installing the contacts, verify their integrity by performing a blank check using a multimeter. Handle with care.

Damaged contacts due to any of the above will invalidate the warranty.

Table

Correspondence between coloured cables of previous contacts type and the cable entry of the current contacts type, in case of replacement.

Cables colour of previous contacts with integral cable	Cable entry of current contacts with PG7 connector
Brown	1
Green	2
White (common)	3

4.2 Potentiometer transmitter

The potentiometer transmitter allows continuous remote reading of the liquid level. A potentiometer is a device comprising a printed circuit board on which a reed / resistance chain is welded and is placed inside the float's vertical weather-proof tube (outside the level indicator). The total resistance of a known value is measured at the ends of this potentiometer.

The float, following the liquid level trend, activates the potentiometer's reed contact chain through its own magnetic field, locally closing the signal. The total resistance value is measured between 0 and 100% of the maximum or total travel. The end poles of the potentiometer are connected to a converter that transforms the input value into Ohm and the output into mA.

4.2.1 Transmitter characteristics

	5 mm
Reading resolution available	10 mm
	20 mm
Resistance input	0,5 k ÷ 100 k Ohm
Maximum allowable temperature	-20°C to +100°C

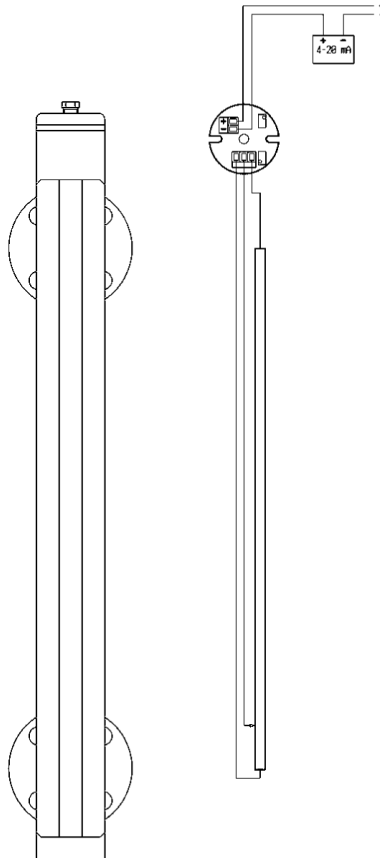

4.2.2 Converter's housings

Three types of housings are available, depending on the design conditions:

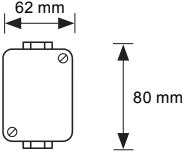
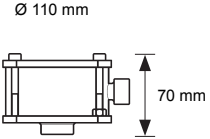
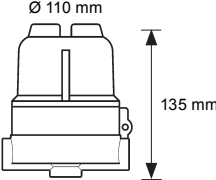
<p>Housing for safe area</p> <p>Weather-proof IP65, Plastic material. Process temperature max 180°C min -20°C</p>	
<p>Housing for safe area, low / high temperature</p> <p>Special design suitable for low temperatures or installation in high concentration saline environments and for use in the food industry. Fully in Stainless Steel material. Enclosure IP67. On request IP68. Up to two cable entries. Operating temperature >180°C</p>	
<p>Housing for hazardous area</p> <p>Explosion version ATEX certified (Ex) II 2GD Ex db IIC T6 Gb Ex tb IIIC T85°C Db for use in hazardous areas. Die-cast Aluminium material, with a Polyamide painting. Enclosure degree IP67. Up to two cable entries maximum.</p>	

Explosion-proof housing operating limits

Technical data	Class I: simple protective-earth connection requirements
-----------------------	--

Employment data for potentially explosive atmospheres

Ambient temperature limits	-20 ÷ 40°C
Marking	(Ex) II 2GD Ex db IIC T6 Gb Ex tb IIIC T85°C Db
Temperature class	T6
Allowed temperature range	-20 ÷ 40°C
Suitability for class areas: 1, 2, GAS Group II (European Directive ATEX 1999/92/EC)	

Remark: ATEX not applicable to Viscorol PH.

Warning:

1. Do not make any modification to the housing. Any alterations or modifications to the product will invalidate any warranties, explosion proof characteristics and any CEx marking.
2. Install at the inlet of the housing a suitable fixing or locking device with filling material. The absence of these components will result in the loss of responsibility of the manufacturer.
3. These products should only be used for what they are designed for. Anything outside of the stipulated application range may be subject to unforeseen and dangerous circumstances and full responsibility will be with the installer.

-
4. All accessories intended for the entrance of the cables and for the closure of the holes not used, must be certified according to the standards EN 60079-0, EN 60079-1, EN 61241-0, EN 61241-1 and must be at least IP66/IP67.
 5. The temperature inside the housing can be $>70^{\circ}\text{C}$ at the cable entry point. Consequently, the cables must be dimensioned appropriately.
 6. **Attenzione:** always verify the correct performance of the grounding devices. Specific connecting points are provided on board the instrument (see next section).

4.2.3 Converter features

Ohm-mA signal converters are fitted inside the housing. Three types of converter are available:

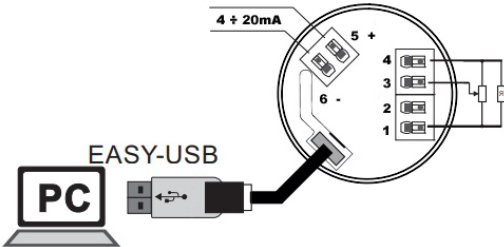
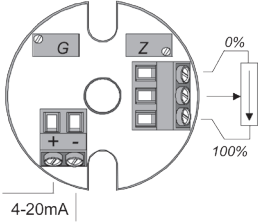
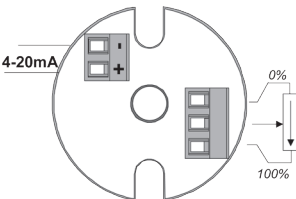
<p>Converter for safe area</p> <p>Field-adjustable converter by software.</p>	
<p>Converter for intrinsically safe area, ATEX certified</p> <p>II 1 G Ex ia IIC T6, T5 o T4 II 1 D iaD A20 IP6X T80°C, T95°C, T130°C</p> <p>Field-adjustable converter with two 10-turns trimmers for the calibration of Z (Zero) and G (Gain), without any interconnection system.</p>	
<p>Converter Hart® protocol version 5.3 for intrinsically safe area, ATEX certified</p> <p>Adjustable converter with interconnection cable.</p>	

Resistance input	0,5 k ÷ 100 k Ohm
Current output	4÷20 mA

4.3 Valves

The level indicators are supplied as standard, with a drainage hole and a SS plug. (A vent hole can also be supplied on request). Upon request drain and vent valves can be supplied.

Note: Isolation valves between the indicator attachments and the tank should be installed to aid maintenance work.

5. Grounding

The requirement for compliance with the 2014/34/UE (ATEX) Directive, even on the instrument scale devoid of electrical equipment, involves the use of the grounding in the methods described below.

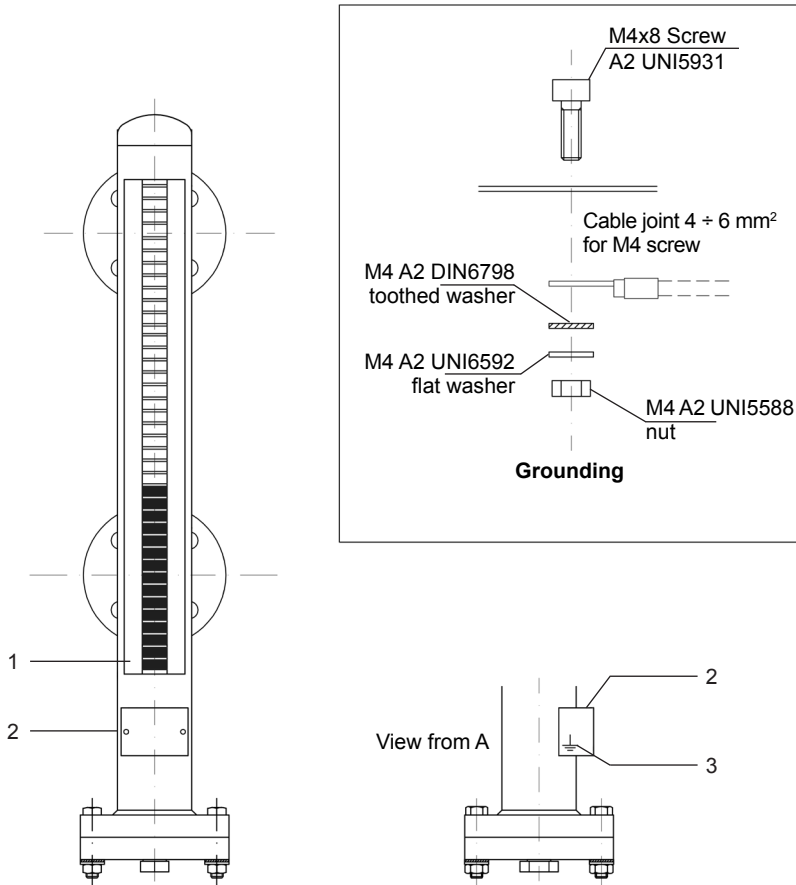

spirax sarco Made in Italy		MODELLO Model	
CE		N° FABBRICA Serial nr	
CAE		T min _____ °C	
PISCO Weight		PRESSIONE DI PROVA Test pressure	
Kg		bar/MPa	
GRUPPO FLUIDO Fluid group		VOLUME Volume	
CONDIZIONI DI PROGETTO Design condition		LITRI Litres	
bar/°C		ANNO Year	
CE Ex II 2GD			

Do not remove or tamper with the connection between the instrument scale (1) and the nameplate bracket (2).

Connect the earthing screw (3) to the ground as shown in the picture of the instrument on pag. 16 (minimum cross-section cable grounding = 4 mm²).

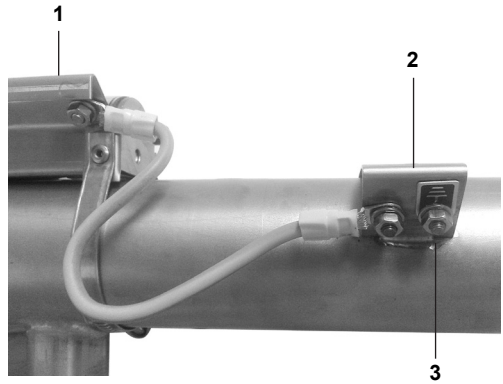
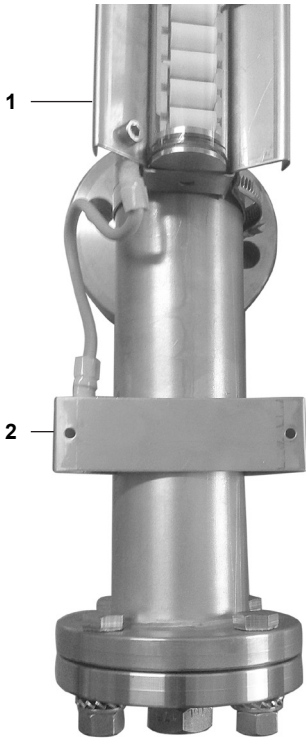

Caution: after every disassembly and reassembly of the closure flange, always make sure of the presence of locking washers (see below).

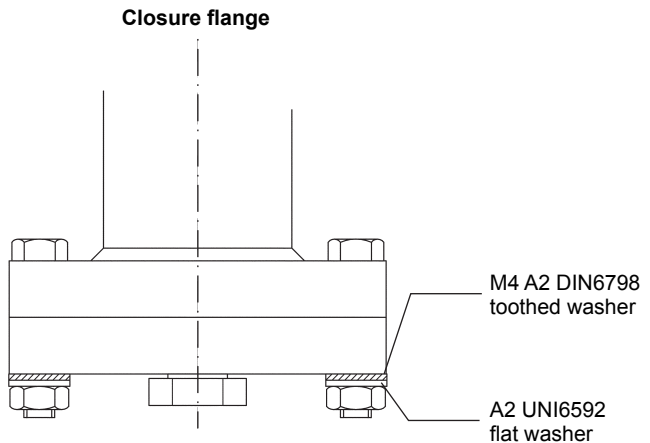

6. Spare parts

The available spare parts are detailed below. No other parts are supplied as spares.

Available spares

Float	5
Tube with rollers / indicator	2, 3 and 4
Scale	1
Electric components	6 and 7

How to order spares

Always order spares by using the description given in the column headed 'Available spares' and state the size and serial number of the unit which is indicated on the name-plate.

Example: 1 Float for a Spirax Sarco Colima Visco having the following serial number: 000000.

spirax sarco Made in Italy		MODELLO Model
CE		N° FABBRICA Serial nr
CAT		T min _____ °C
PIESO Weight	Kg	GRUPPO FLUIDO Fluid group
CONDIZIONI DI PROGETTO Design condition		PRESSIONE DI PROVA Test pressure
		bar/g
		VOLUME Volume
		LITRI Litres
		ANNO Year

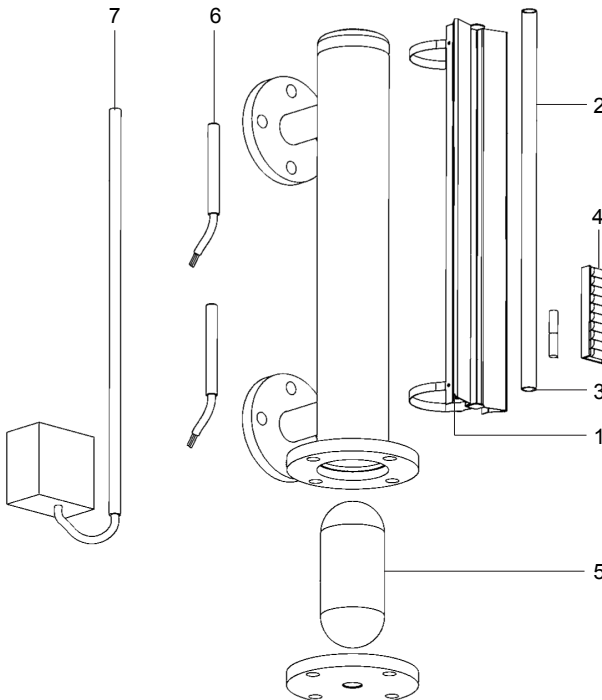

SERVICE

For technical support, please contact our local Sales Engineer or our Head Office directly:

Spirax Sarco S.r.l. - Technical Assistance

Via per Cinisello, 18 - 20834 Nova Milanese (MB) - Italy

Tel.: (+39) 0362 4917 257 - (+39) 0362 4917 211 - Fax: (+39) 0362 4917 315

E-mail: support@it.spiraxsarco.com

LOSS OF GUARANTEE

Total or partial disregard of above instructions involves loss of any rights to guarantee.

Spirax-Sarco S.r.l. - Via per Cinisello, 18 - 20834 Nova Milanese (MB) - Tel.: 0362 49 17.1 - Fax: 0362 49 17 307