

# spirax sarco

## UTD30L, UTD30LA, UTD30H and UTD30HA

### Thermodynamic Steam Traps with Swivel Connector

#### Description

The UTD30 series are stainless steel thermodynamic steam traps with integral strainer having an electroless nickel preparation finish (ENP) which is both energy efficient and corrosion resistant. They are attached to a suitable pipeline connector by two bolts for quick and easy replacement.

- UTD30L** - Low capacity for mains drainage and tracing applications.
- UTD30LA** - Low capacity for mains drainage and tracing applications plus anti-air-binding disc.
- UTD30H** - For higher capacity applications.
- UTD30HA** - For higher capacity applications plus anti-air-binding disc.

#### Standards and Certification

These products fully comply with the requirements of the Indian Boiler Regulations, 1950.

**Note:** All certification / inspection requirements must be stated at the time of order placement.

#### Pipeline connector options

The UTD30 can be fitted to a variety of pipeline connectors:

<b>PC10HP</b>	Straight connector	ASME 600
<b>PC3_</b>	Straight connector with one piston isolation valve	ASME 600
<b>PC4_</b>	Straight connector with two piston isolation valves	ASME 600

#### Pressure / temperature limits (ISO 6552)

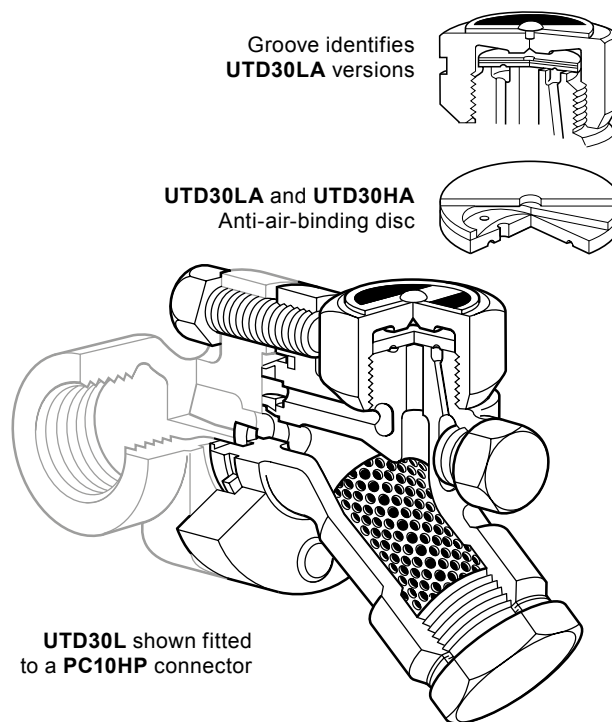
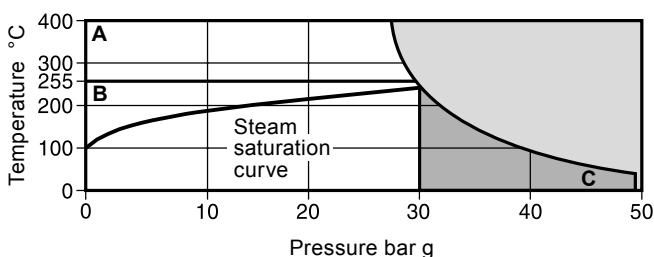

- The product **must not** be used in this region.
- For optimum product performance the PMO should not exceed 30 bar g.
- A - C** UTD30L and UTD30H
- B - C** UTD30LA and UTD30HA

**Note:** The model of pipeline connector and connection selected will dictate the maximum operating limits of the complete assembly. Reference the specific pipeline connector Technical Information sheet as detailed in 'Pipeline connector options'.

Body design conditions		PN50
PMA	Maximum allowable pressure	50 bar g @ 38 °C
TMA	Maximum allowable temperature	400 °C @ 27.5 bar g
Minimum allowable temperature		0 °C
PMO	Maximum operating pressure for saturated steam service	30 bar g
TMO	Maximum operating temperature	UTD30L and UTD30H 400 °C @ 27.5 bar g
		UTD30LA and UTD30HA 255 °C @ 30 bar g
Minimum operating temperature		<b>Note:</b> For lower operating temperatures consult Spirax Sarco 0 °C
ΔPMX	Maximum differential pressure	30 bar
PMOB	Maximum operating backpressure should not exceed 80% of the upstream pressure	
Minimum inlet pressure for satisfactory operation		0.25 bar g
Designed for a maximum cold hydraulic test pressure of		75 bar g

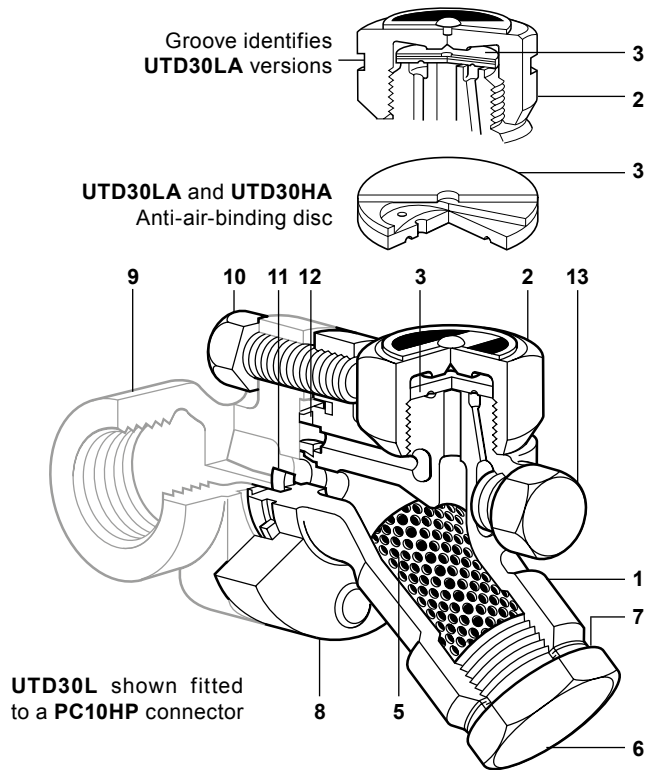

**Materials**

No.	Part	Material	
1	Body	Stainless steel - ENP	ASTM A743 Gr. CA 40
2	Cap	Stainless steel	ASTM A582 416
3	Disc	UTD30L and UTD30H	Stainless steel AISI 420
		UTD30LA and UTD30HA	Stainless steel AISI 420
			Bimetal
5	Strainer screen	Stainless steel	AISI 304
6	Strainer cap	Stainless steel	ASTM A582 416
7	Strainer cap gasket	Stainless steel	AISI 304
8	Flange	Alloy steel - ENP	ASTM A193 B7
9	Pipeline connector	Stainless steel	ASTM A351 CF8
10	Connector screw	Steel	ASTM A193 B7
11	Inner gasket	Graphite/ Stainless steel laminate	AISI 316 strip
12	Outer gasket	Graphite/ Stainless steel laminate	AISI 316 strip
13	Plug	Stainless steel	ASTM A276.431
14	Insulating cover (optional)	Aluminium	

**Dimensions / weights (approximate) in mm and kg**

A	B	C	D	E	F	Weight
67	41	55	85	57	38	1.10

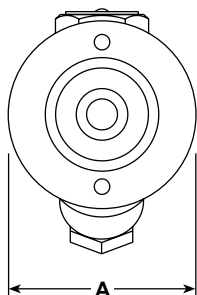

Withdrawal distance for strainer screen

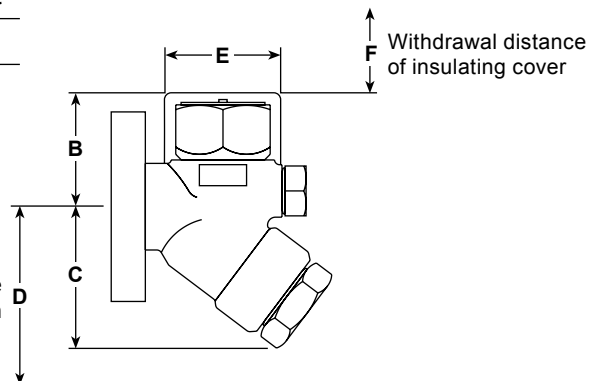

## Capacities

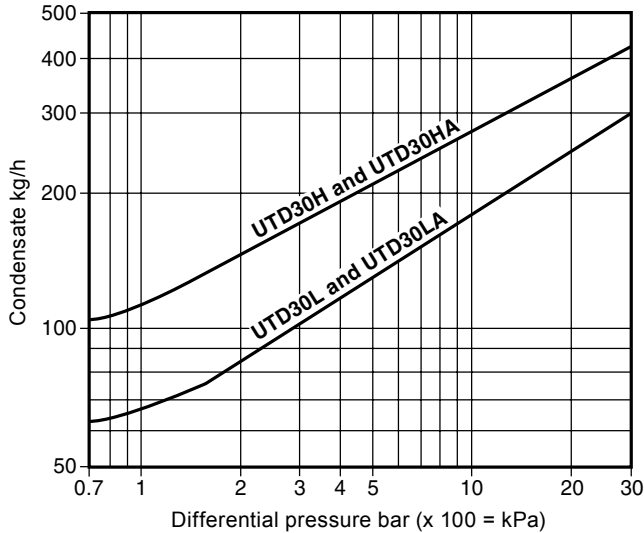

## Optional extras

**Insulating cover:** To prevent the trap being unduly influenced by excessive heat loss such as when subjected to low outside temperatures, wind, rain etc.

**How to order** The UTD30 is supplied in two parts:-

	PC10HP	Standard connection
1. The swivel pipeline connector	PC3_	+ 1 integral ISO valve
	PC4_	+ 2 integral ISO valves

The UTD30 trap complete with inner and outer gaskets and two connector screws.

- Available as follows: UTD30L, UTD30H, UTD30LA or UTD30HA.  
Items will be supplied in a protective box.

**Note:** Any optional extras need to be specified at the time of order placement.

### How to order example:

1 off Spirax Sarco DN20 PC10HP swivel pipeline connector with socket weld connections.

1 off Spirax Sarco UTD30LA thermodynamic steam trap fitted with an anti-air-binding disc. The unit is supplied complete with connector screws and gaskets.

1 off Insulating cover to fit a UTD30LA.

## Safety information, installation and maintenance

For full details see the Installation and Maintenance Instructions (IM-IBR15-23-IN) supplied with the product.

### Installation note:

The pipeline connector can be installed in either horizontal or vertical pipework but the trap body must always have the cap (2) uppermost.

### Disposal:

This product is recyclable. No ecological hazard is anticipated with the disposal of this product providing due care is taken.

## Spare parts

The spare parts available are shown in solid outline. Parts drawn in a grey line are not supplied as spares.

### Available spares

Complete trap unit assembled (state unit nomenclature), excluding pipeline connector.

Gasket set (packet of 3)		<b>11, 12</b>
Disc (packet of 3)	UTD30L and UTD30H	<b>3</b>
Strainer screen	UTD30L and UTD30H	<b>5</b>
Disc and strainer screen	UTD30LA and UTD30HA	<b>3, 5</b>
Strainer screen gasket		<b>7</b>
Insulating cover		<b>14</b>

### How to order spares

Always order spare parts by using the description given in the column headed 'Available spares' and state the size and type of trap.

**Example:** 1 off packet of 3 discs for a Spirax Sarco UTD30L thermodynamic steam trap with swivel connector.

