



TD42LC and TD42 Thermodynamic Steam Traps

Description

The TD42LC and TD42 are maintainable thermodynamic steam traps. The TD42LC is specifically designed for relatively small condensate loads and therefore is ideal for mains drainage applications. For process type loads the TD42 is available. For those applications where the release of air is a concern, an anti-air-binding disc is available i.e. TD42LCA and TD42A.

Standards

These products fully comply with the requirements of the Indian Boiler Regulations, 1950.

Certification

This product is available with a manufacturer's Typical Test Report and IBR certification.

Note: All certification/inspection requirements must be stated at time of order placement.

Sizes and pipe connections

TD42LC	3/8", 1/2" and 3/4"	screwed BSP or NPT
TD42	1/2", 3/4" and 1"	screwed BSP or NPT
TD42LCA	3/8", 1/2" and 3/4"	screwed BSP or NPT
TD42A	1/2" and 3/4"	screwed BSP or NPT

Optional extras

Insulating cover: to prevent the trap being unduly influenced by excessive heat loss such as when subjected to low outside temperatures, wind, rain etc.

Pressure / temperature limits (ISO 6552)

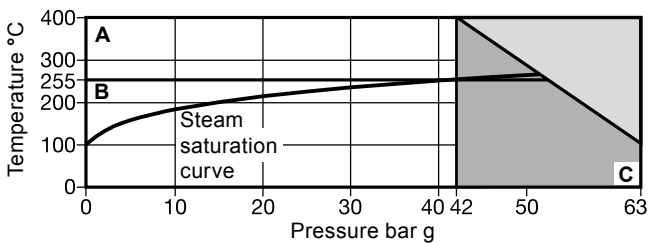

The product **must not** be used in this region.

For optimum product performance the PMO should not exceed 42 bar g.

A - C TD42LC and TD42 **B - C** TD42LCA and TD42A

Body design conditions		PN63
PMA	Maximum allowable pressure	63 bar g @ 100 °C
TMA	Maximum allowable temperature	400 °C @ 42 bar g
Minimum allowable temperature		0 °C
PMO	Maximum operating pressure	42 bar g
TMO	Maximum operating temperature	TD42LC and TD42 400 °C @ 42 bar g
		TD42LCA and TD42A 255 °C @ 42 bar g
Minimum operating temperature		0 °C
Minimum inlet pressure for satisfactory operation	TD42LC and TD42	0.25 bar g
	TD42LCA and TD42A	0.80 bar g
PMOB	Maximum operating backpressure should not exceed 80% of the upstream pressure	
Designed for a maximum cold hydraulic test pressure of 94.5 bar g		

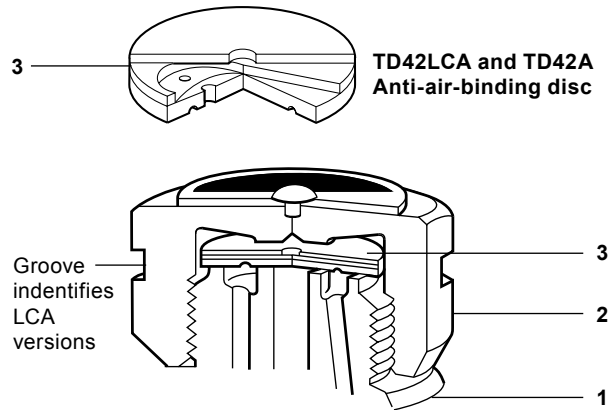
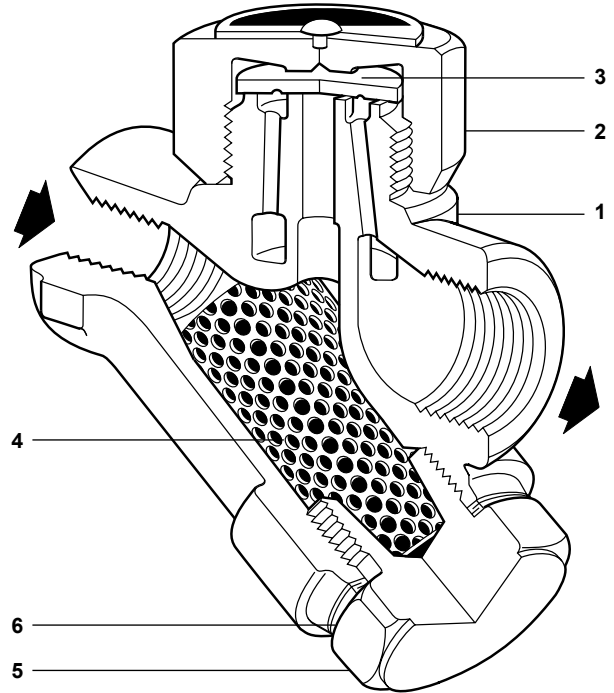

Materials

No.	Part	Material
1	Body	Stainless steel ASTM A743 CA 40
2	Cap	Stainless steel ASTM A582 416
3	Disc	Stainless steel AISI 420
4	Strainer screen	Stainless steel AISI 304
5	Strainer cap	Stainless steel ASTM A582 416
6	Strainer cap gasket	Stainless steel AISI 304
7	Insulating cover (optional extra)	Aluminium

Capacities

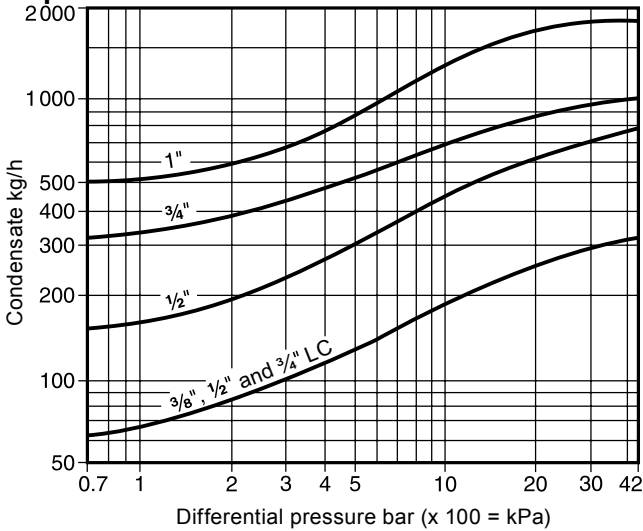

Dimensions/weights (approximate) in mm and kg

Size	A	B	E	G	H	J	K	L	Weight
3/8"	41	78	55	85	20	52	57	38	0.80
1/2" LC	41	78	55	85	20	52	57	38	0.75
3/4" LC	44	85	60	100	20	52	57	38	0.95
1/2"	41	78	55	85	41	57	57	38	0.80
3/4"	47	90	60	100	41	63	57	38	1.00
1"	53	96	66	100	41	-	-	-	1.50

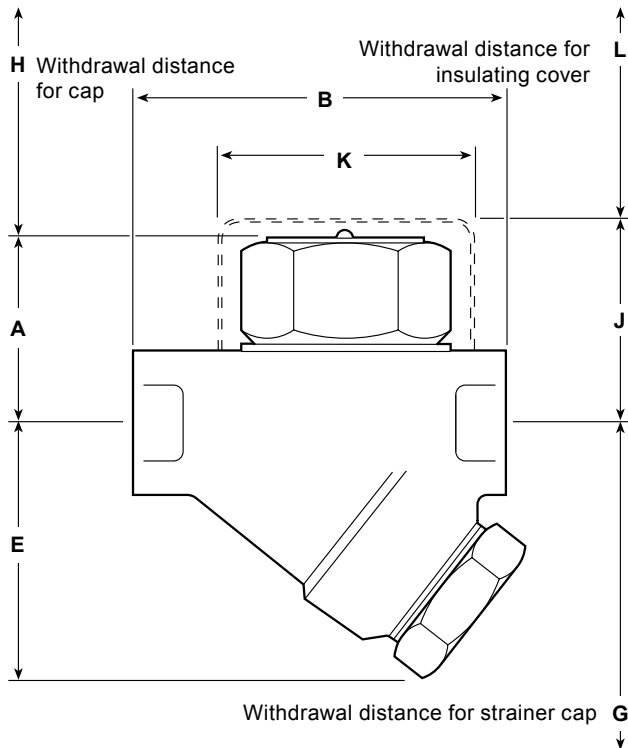

Safety information, installation and maintenance

For full details see the Installation and Maintenance Instructions (IM-IBR15-17IN) supplied with the product.

Installation note: The TD42LC and TD42 should be installed in the horizontal plane, with a small drop leg proceeding them.

Disposal: This product is recyclable. No ecological hazard is anticipated with the disposal of this product providing due care is taken.

How to order

Example: 1 off Spirax Sarco 1/2" TD42LC thermodynamic steam trap having screwed BSP connections.

Spare parts

The spare parts available are shown in solid outline. Parts drawn in broken line are not supplied as spares.

Available spares

Disc (packet of 3)	(TD42LC or TD42)	3
Disc and strainer screen	(TD42LCA or TD42A)	3, 4, 6
Strainer screen and gasket	(TD42LC or TD42)	4, 6
Insulating cover		7
Strainer cap gasket (packet of 3)		6

How to order spares

Always order spares by using the description given in the column headed 'Available spares' and state the size and type of trap.

Example: 1 - Strainer screen and gasket for a Spirax Sarco 1/2" TD42LC thermodynamic steam trap.

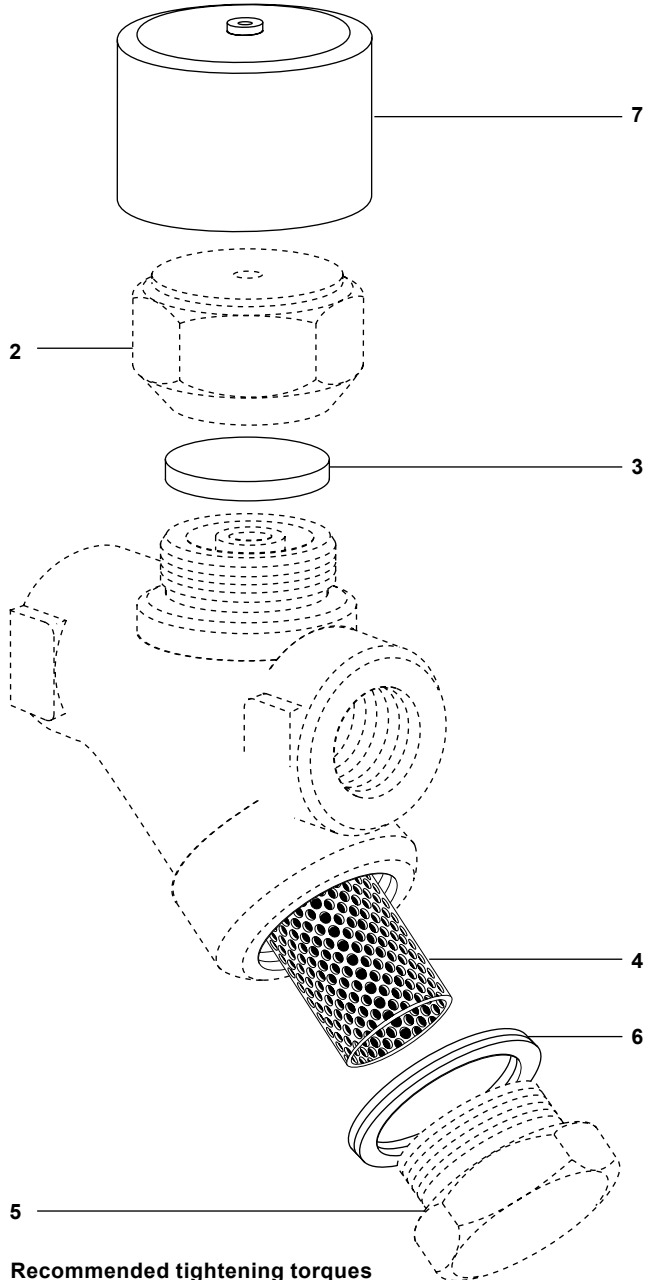

Recommended tightening torques

Item	or mm	N m
(TD42LC - all sizes)	36 A/F	135 - 150
2 (TD42 - 1/2", 3/4")	41 A/F	180 - 200
(TD42 - 1")	55 A/F	250 - 275
5	32 A/F M28	170 - 190