

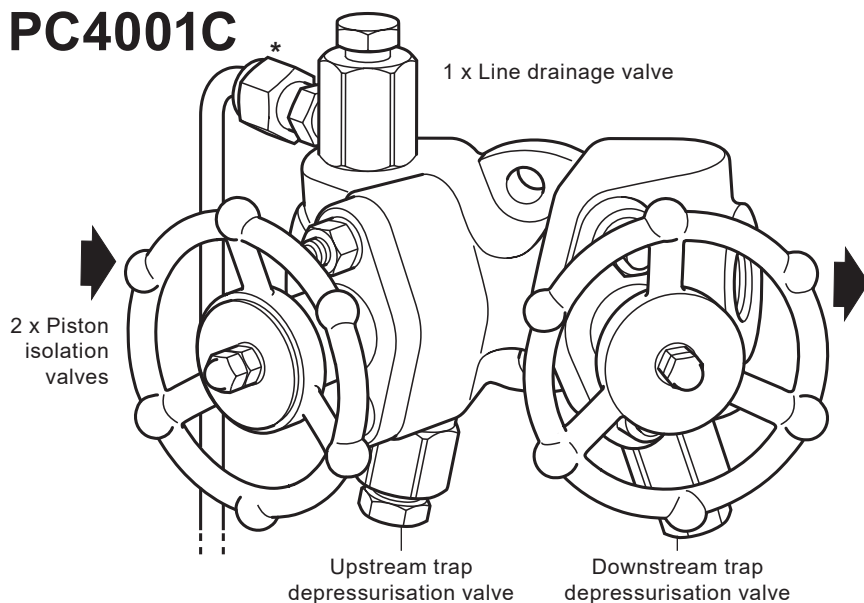

TI-IBR17-70IN
CMGT Issue 1

PC4001C and PC4000C Pipeline Connectors For the Oil & Gas Industry

PC4001C



* **Please note** that the line drain outlet is shown out of position for clarity and that the line drain pipework is to be supplied by the customer.

PC4000C

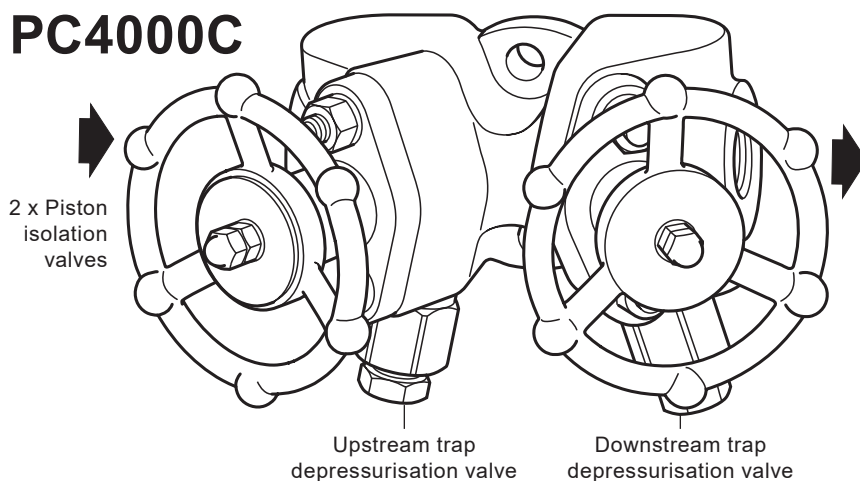

Description

The PC4001C and PC4000C range of pipeline connectors are a complete 'Trap valve station solution' developed for use with two bolt universal swivel connector steam traps.

As the unit has been designed with two integral piston stop valves, it is possible to isolate both upstream and downstream of the universal trap connection.

PC4001C and PC4000C models only

Through the use of the fitted depressurisation valves it is possible to depressurise, test and drain the pipeline.

The trap depressurisation port also incorporates a maintainable 40 mesh stainless steel strainer screen to provide trap protection from system dirt and debris, which can be cleared through the use of the line pressure.

Available types

Model	Valve connections	P and ID diagram	Flow direction
PC4001C	2 x Piston isolation valves 1 x Upstream trap depressurisation valve 1 x Downstream trap depressurisation valve 1 x Line drain valve		Left to right or Right to left
PC4000C	2 x Piston isolation valves 1 x Upstream trap depressurisation valve 1 x Downstream trap depressurisation valve		Left to right or Right to left

For available options to the pipeline connections detailed within this Technical Information sheet please reference TI-F01-37.

Standards - These products fully comply with the requirements of the Indian Boiler Regulations, 1950.

Note: All certification / inspection requirements must be stated at the time of order placement. For other certification contact Spirax Sarco.

Sizes and pipe connections

DN15 and DN20 condensate inlet / outlet connections are available with screwed BSP or NPT and as a socket weld connection to ASME B16.11 class 3000. Drainage and venting connections have an M18 thread as standard.

Flanged versions are also available upon request. Please contact Spirax Sarco for further details.

How to order

Example: 1 off ½" Spirax Sarco PC4001C pipeline connector having right to left flow and socket weld end connections to ASME B 16.11 Class 3000.

No.	Part	Material	
1	Pipeline connector body	Carbon steel	A105 / A350 LF2
2	Bonnet	Carbon steel (Zinc plated)	ASTM A105N / LF2
3	Studs	Steel (plated)	ASTM A193 B7
4	Nuts	Steel (plated)	ASTM A194 2H
5	Washers	Stainless steel	
6	Piston	Stainless steel	AISI 410 : 1.4006
7	Lantern bush	Stainless steel	ASTM A276 : AISI 431
8	Upper ring	Graphite and stainless steel	
9	Lower ring	Graphite and stainless steel	
10	Handwheel	Carbon steel (Zinc plated)	EN 10213 : 1.0619N
11	Handwheel nuts	Stainless steel	
12	Washers	Steel	
13	Name-plate	Stainless steel	
14	Depressurisation valve	Stainless steel	ASTM A182 : 304 / 304L
15	Line drain valve	Stainless steel	ASTM A182 : 304 / 304L
16	Valve screw	Stainless steel	ASTM A276 : AISI 431
17	Valve cone	Stainless steel	AISI 440 B
18	Retaining ring	Stainless steel	BS 2056 302 S26
19	Compression fitting for the line drain valve only	Carbon steel (Zinc plated)	
20	Valve gasket	Graphite and stainless steel	
21	Strainer screen	Stainless steel	
22	Depressurisation valve gasket	Graphite	

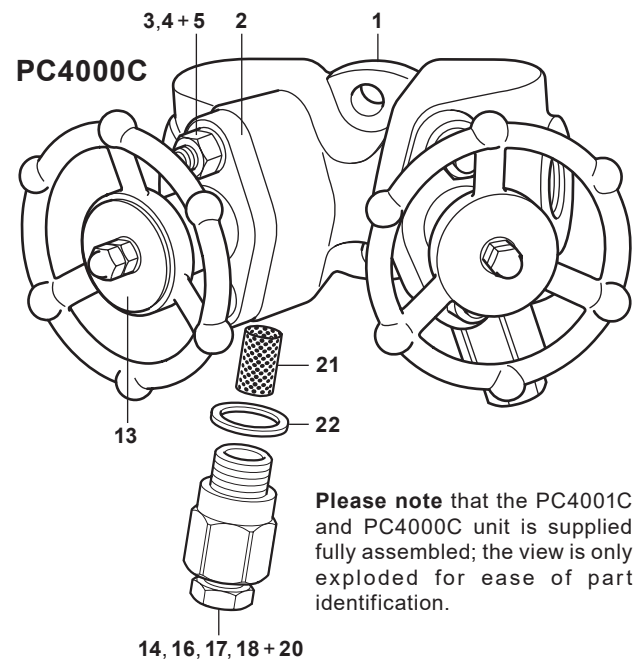
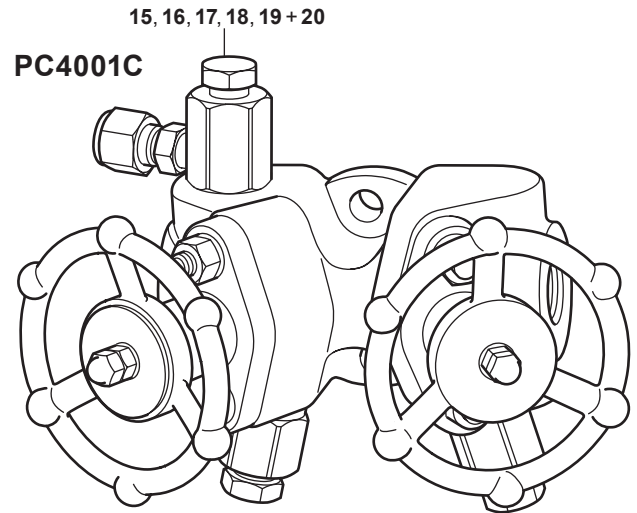

Please note that the PC4001C and PC4000C unit is supplied fully assembled; the view is only exploded for ease of part identification.

View showing valve internals

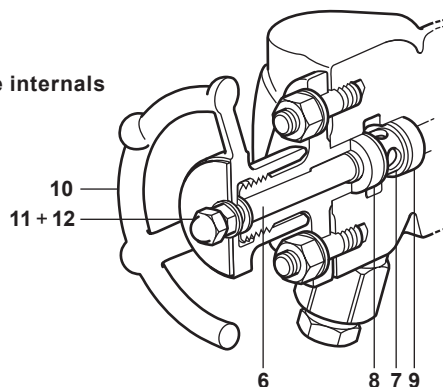

Pressure / temperature limits (ISO 6552)

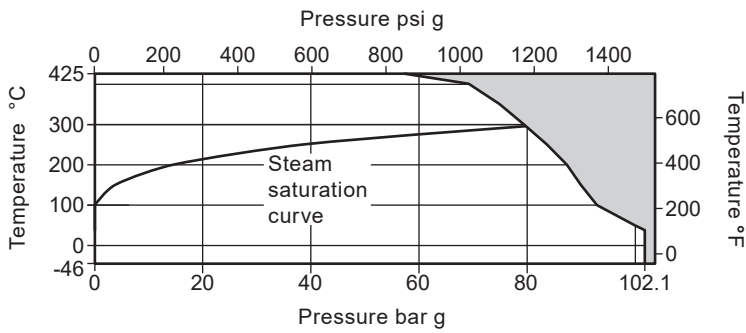

The product **must not** be used in this region or beyond the parameter of the PMA or TMA of the relative end connection - See notes below.

Body design condition			ASME 600
PMA	Maximum allowable pressure	102.1 bar g @ 38 °C	1 480 psi g @ 100 °F
TMA	Maximum allowable temperature	425 °C @ 57.5 bar g	797 °F @ 833 psi g
	Minimum allowable temperature	-46 °C	-51 °F
PMO	Maximum operating pressure for saturated steam service	79.6 bar g @ 300 °C	1 154.5 psi g @ 572 °F
TMO	Maximum operating temperature	425 °C @ 57.5 bar g	797 °F @ 833 psi g
	Minimum operating temperature	-46 °C	-51 °F
Designed for a maximum cold hydraulic test pressure of:			153.2 bar g / 2 221.9 psi g

Notes:

1. If flange connections are fitted then these will limit the maximum and minimum design conditions of the pipeline connector.
2. The maximum operating limits of the complete assembly will be dictated by the steam trap of choice. Reference the specific steam trap technical information sheet for its 'Pressure/temperature limits'.

Dimensions / weight (approximate)

Units	A	B	C	D	E	F	G	H	I	J	Weight
Metric mm	72	36	90	25	50	35	90	99	115	50	3.6 kgs
Imperial inches	2.8"	1.4"	3.5"	1"	2"	1.4"	3.5"	3.9"	4.53"	1.97"	7.9 lbs

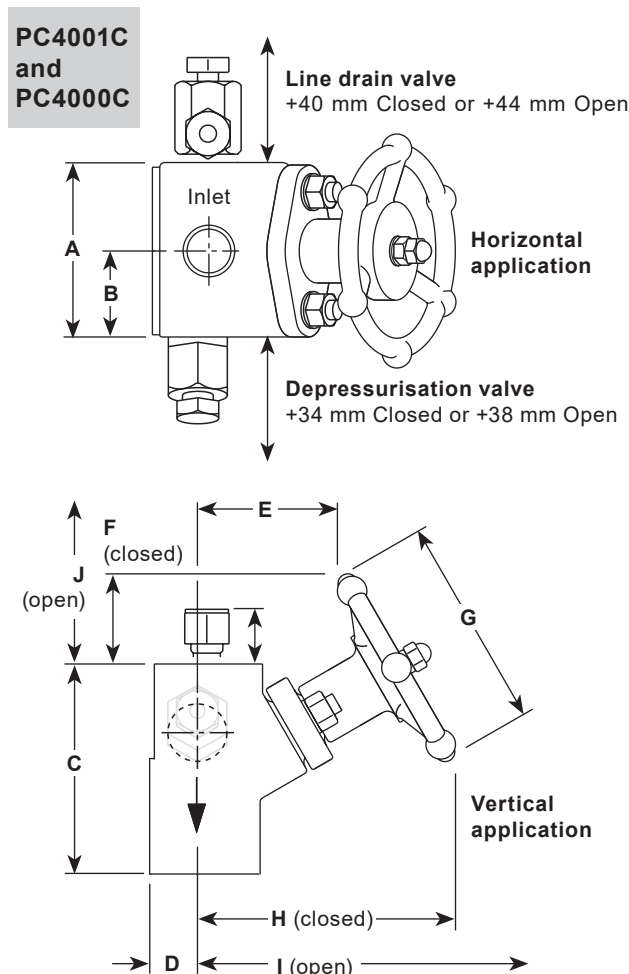

Safety information, installation and maintenance

For full details see the Installation and Maintenance Instructions supplied with the product.

General information

There are two criteria which must be satisfied to ensure that the swivel connector trap will operate correctly and ensure effective condensate removal:

1. The PC4001C, PC4000C and PC40C shall be installed with flow in the direction of the arrow. Flow can be horizontal (left to right or right to left), vertical or inclined.
2. The connection face for the swivel connector steam trap must be in the vertical plane unless stated on relevant steam trap Installation and Maintenance Instructions.

After installation it is recommended that the pipeline connector is insulated to minimise radiated heat losses and to protect personnel from burns risk: Please note that some steam trap types should not be insulated.

Depressurisation and line drainage

The PC4001C and PC4000C assemblies are supplied fitted with valves which allow depressurisation of the system to enable safe removal and maintenance of the steam trap. The PC4001C is also supplied with line drainage fitted, however consideration must be given to the position of the discharge which should be directed or piped to a safe place where it will not injure personnel or damage equipment.

Disposal

This product is recyclable. No ecological hazard is anticipated with the disposal of this product, providing due care is taken.

Spare parts

The spare parts available are shown in heavy outline. Parts drawn in grey line are not supplied as spares. For ease of replacement an extractor tool is available for removing the sealing rings.

Available spares



Sealing ring set	8 and 9
Piston valve assembly	2, 4, 5, 6, 7, 8, 9, 10, 11 and 12
Piston valve sub-assembly	6, 7, 8 and 9
Extractor tool	Not shown
PC depressurisation valve and gasket	14 and 22
PC line drain valve and gasket	15 and 22
Strainer screen and gasket (pack of 3)	21 and 22
Valve gasket set (pack of 10)	22

How to order spares

Always order spares by using the description given in the column headed 'Available spares' and state type and size of equipment.

Example: 1 off Sealing ring set for an integral piston valve on a PC4001C pipeline connector having DN15 socket weld connections.

Recommended tightening torques

Item	 or mm		N m
4	14	5/16" x 18 UNC	12.0
11	10	M6	12.0
14 and 15	24	M18	74 - 78

