

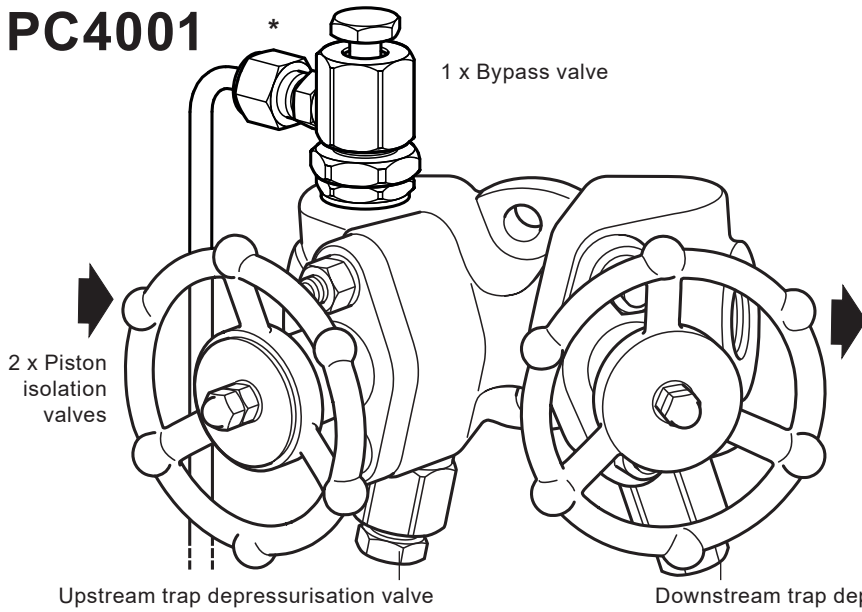

PC4001, PC4000 and PC40 Pipeline Connectors

PC4001



* Please note that the line drain outlet is shown out of position for clarity and that the line drain pipework is to be supplied by the customer.

PC4000

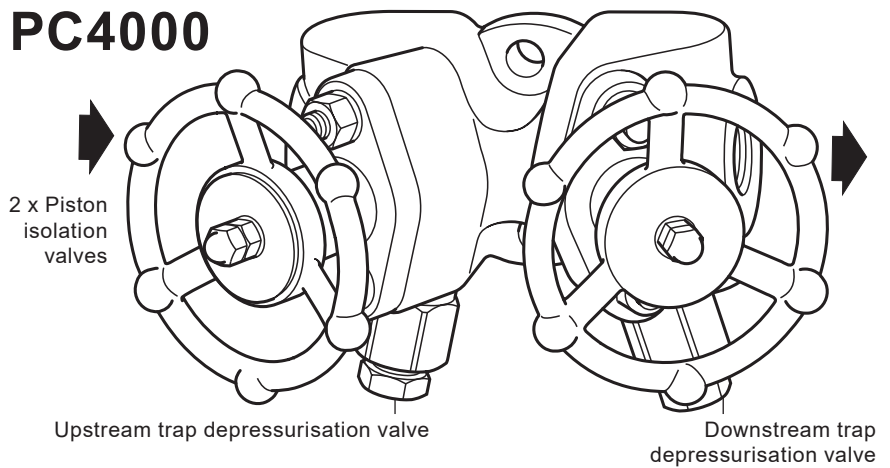

PC40

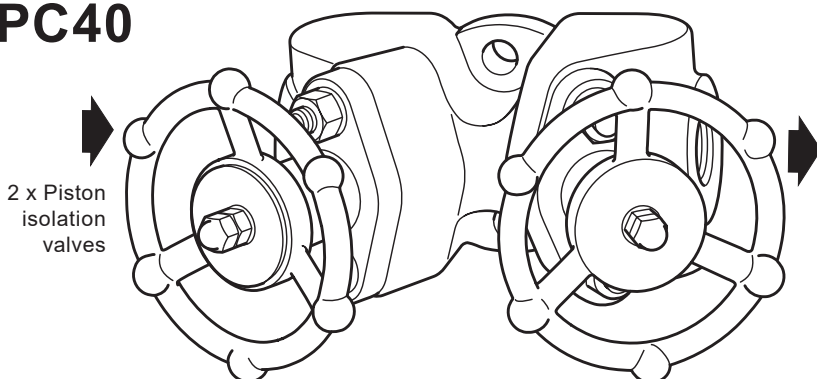

Description

The PC4001, PC4000 and PC40 range of pipeline connectors are a complete 'Trap valve station solution' developed for use with two bolt universal swivel connector steam traps.

As the unit has been designed with two integral piston stop valves, it is possible to isolate both upstream and downstream of the universal trap connection.

PC4001 and PC4000 models only

Through the use of the fitted depressurisation valves it is possible to depressurise, test and drain the pipeline.

The trap depressurisation port also incorporates a maintainable 40 mesh stainless steel strainer screen to provide trap protection from system dirt and debris, which can be cleared through the use of the line pressure.

Available types

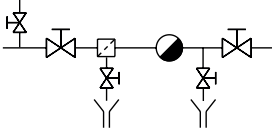
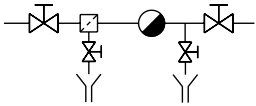
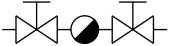
Model	Valve connections	P and ID diagram	Flow direction
PC4001	2 x Piston isolation valves 1 x Upstream trap depressurisation valve 1 x Downstream trap depressurisation valve 1 x Bypass valve		<p>Left to right</p> <p>→</p> <p>or</p> <p>←</p> <p>Right to left</p>
PC4000	2 x Piston isolation valves 1 x Upstream trap depressurisation valve 1 x Downstream trap depressurisation valve		
PC40	No valve connections		

For available options to the pipeline connections detailed within this Technical Information sheet please reference TI-F01-37.

Standards - These products fully comply with the requirements of the Indian Boiler Regulations 1950.

Note: All certification/inspection requirements must be stated at the time of order placement. For other certification contact Spirax Sarco.

Sizes and pipe connections

DN15 and DN20 condensate inlet / outlet connections are available with screwed BSP or NPT and as a socket weld connection to ASME B16.11 class 3000. Drainage and venting connections have an M18 thread as standard.

Flanged versions are also available upon request. Please contact Spirax Sarco for further details.

How to order

Example: 1 off ½" Spirax Sarco PC4001 pipeline connector having right to left flow and socket weld end connections to ASME B 16.11 Class 3000.

Materials

No.	Part	Material	
1	Pipeline connector body	Austenitic stainless steel	ASTM A182F : 304/304L
2	Bonnet	Carbon steel (Zinc plated)	ASTM A105N/LF2
3	Studs	Steel (plated)	ASTM A193 B7
4	Nuts	Steel (plated)	ASTM A194 2H
5	Washers	Stainless steel	
6*	Piston	Stainless steel	AISI 410 : 1.4006
7*	Lantern bush	Stainless steel	ASTM A276 : AISI 431
8*	Upper ring	Graphite and stainless steel	
9*	Lower ring	Graphite and stainless steel	
10*	Handwheel	Carbon steel (Zinc plated)	EN 10213 : 1.0619N
11*	Handwheel nuts	Stainless steel	
12*	Nitronic 60 washers	Stainless steel	
13	Name-plate	Stainless steel	
14	Depressurisation valve	Stainless steel	ASTM A182 : 304/304L
15	Bypass valve	Stainless steel	ASTM A182 : 304/304L
16	Valve screw	Stainless steel	ASTM A276 : AISI 431
17	Valve cone	Stainless steel	AISI 440 B
18	Retaining ring	Stainless steel	BS 2056 302 S26
19	Compression fitting for the line drain valve only	Carbon steel (Zinc plated)	
20	Valve gasket	Graphite and stainless steel	
21	Bypass locknut	Stainless steel	ASTM A276: AISI 431
22	Graphite ring	Die-formed graphite	
23	Bypass bottom body	Stainless steel	ASTM A182 304/304L
24	Strainer screen	Stainless steel	

PC4001

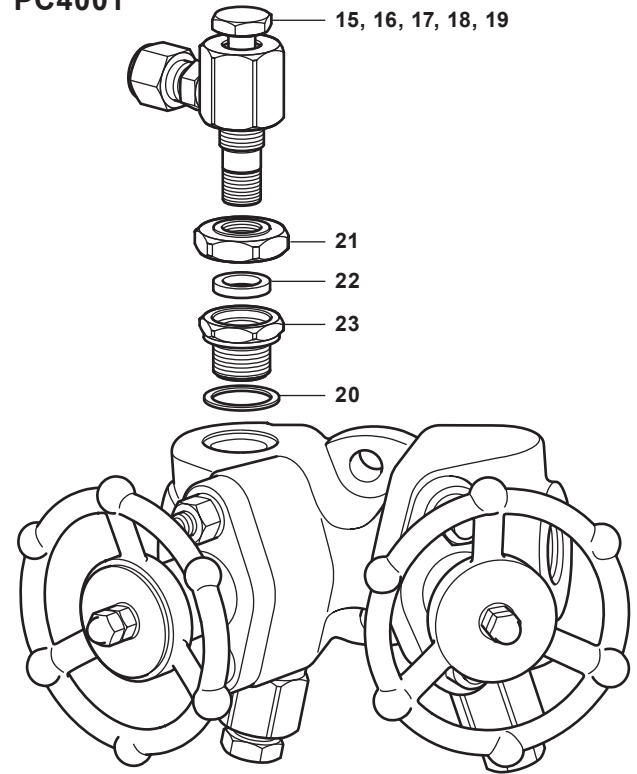

PC4000

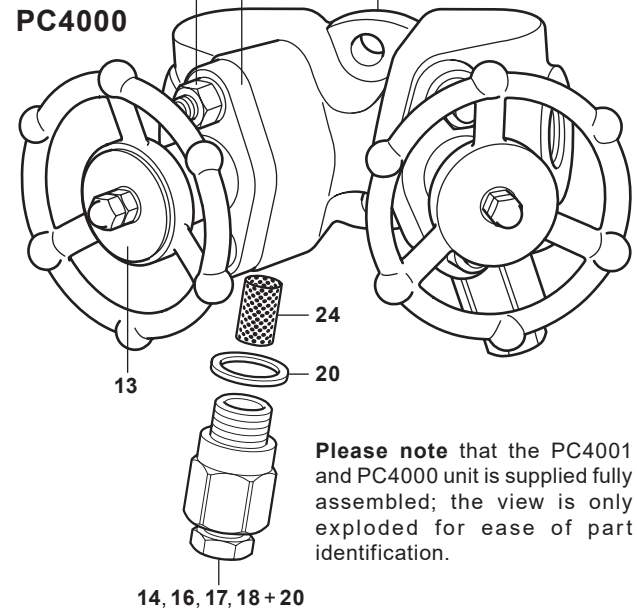

Please note that the PC4001 and PC4000 unit is supplied fully assembled; the view is only exploded for ease of part identification.

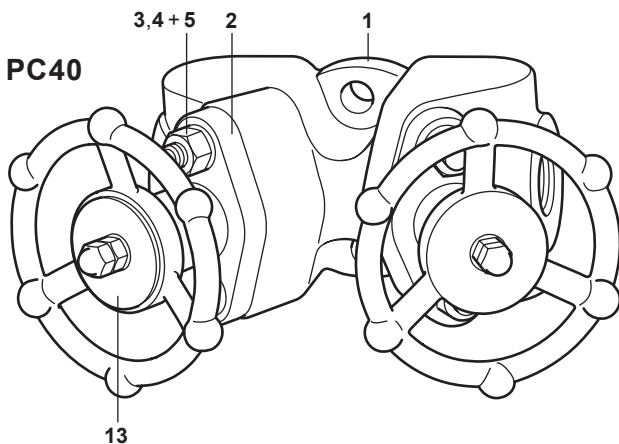

* For valve internal materials, see next page

Valve internal materials

No. Part	Material		
6	Piston	Stainless steel	AISI 410 : 1.4006
7	Lantern bush	Stainless steel	ASTM A276 : AISI 431
8	Upper ring	Graphite and stainless steel	
9	Lower ring	Graphite and stainless steel	
10	Handwheel	Carbon steel (Zinc plated)	EN 10213 : 1.0619N
11	Handwheel nuts	Stainless steel	
12	Nitronic 60 washers	Stainless steel	

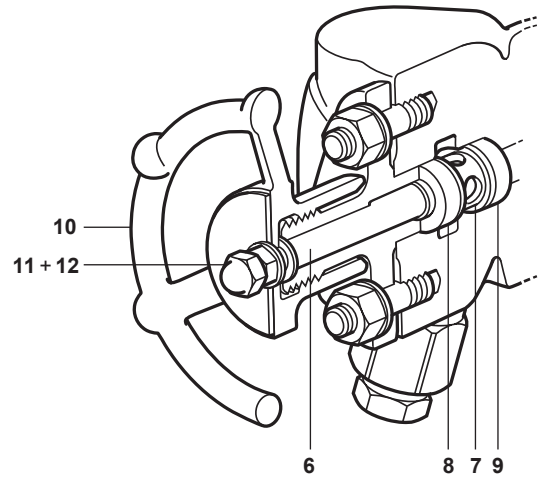

Pressure/temperature limits (ISO 6552)

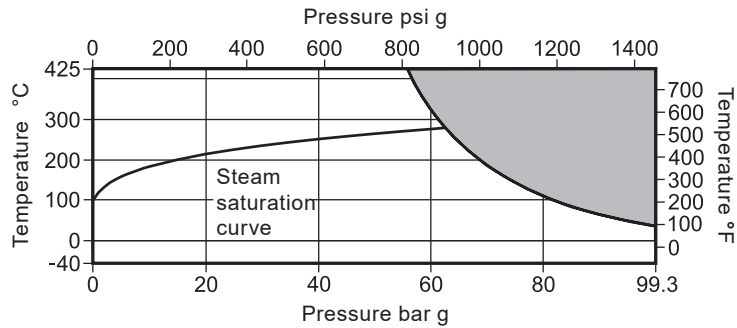

The product **must not** be used in this region or beyond the parameter of the PMA or TMA of the relative end connection - See notes below.

Body design condition	ASME 600	
PMA Maximum allowable pressure	99.3 bar g @ 38 °C	1440 psi g @ 100 °F
TMA Maximum allowable temperature	425 °C @ 56 bar g	797 °F @ 812 psi g
Minimum allowable temperature	-46 °C	-51 °F
PMO Maximum operating pressure for saturated steam service	62 bar g @ 279 °C	899 psi g @ 534°F
TMO Maximum operating temperature	425 °C @ 56 bar g	797 °F @ 812 psi g
Minimum operating temperature	-46 °C	-51 °F
Designed for a maximum cold hydraulic test pressure of:	149 bar g	2161.06 psi g

Notes:

1. If flange connections are fitted then these will limit the maximum and minimum design conditions of the pipeline connector.
2. The maximum operating limits of the complete assembly will be dictated by the steam trap of choice. Reference the specific steam trap technical information sheet for its 'Pressure/temperature limits'.

Dimensions/weight (approximate)

Units	A	B	C	D	E	F	G	H	I	J	Weight
Metric mm	72	36	124	25	52	37	95	100	118	50	3.6 kgs
Imperial inches	2.8"	1.4"	4.9"	1"	2"	1.5"	3.7"	3.9"	4.64"	1.97"	7.9 lbs

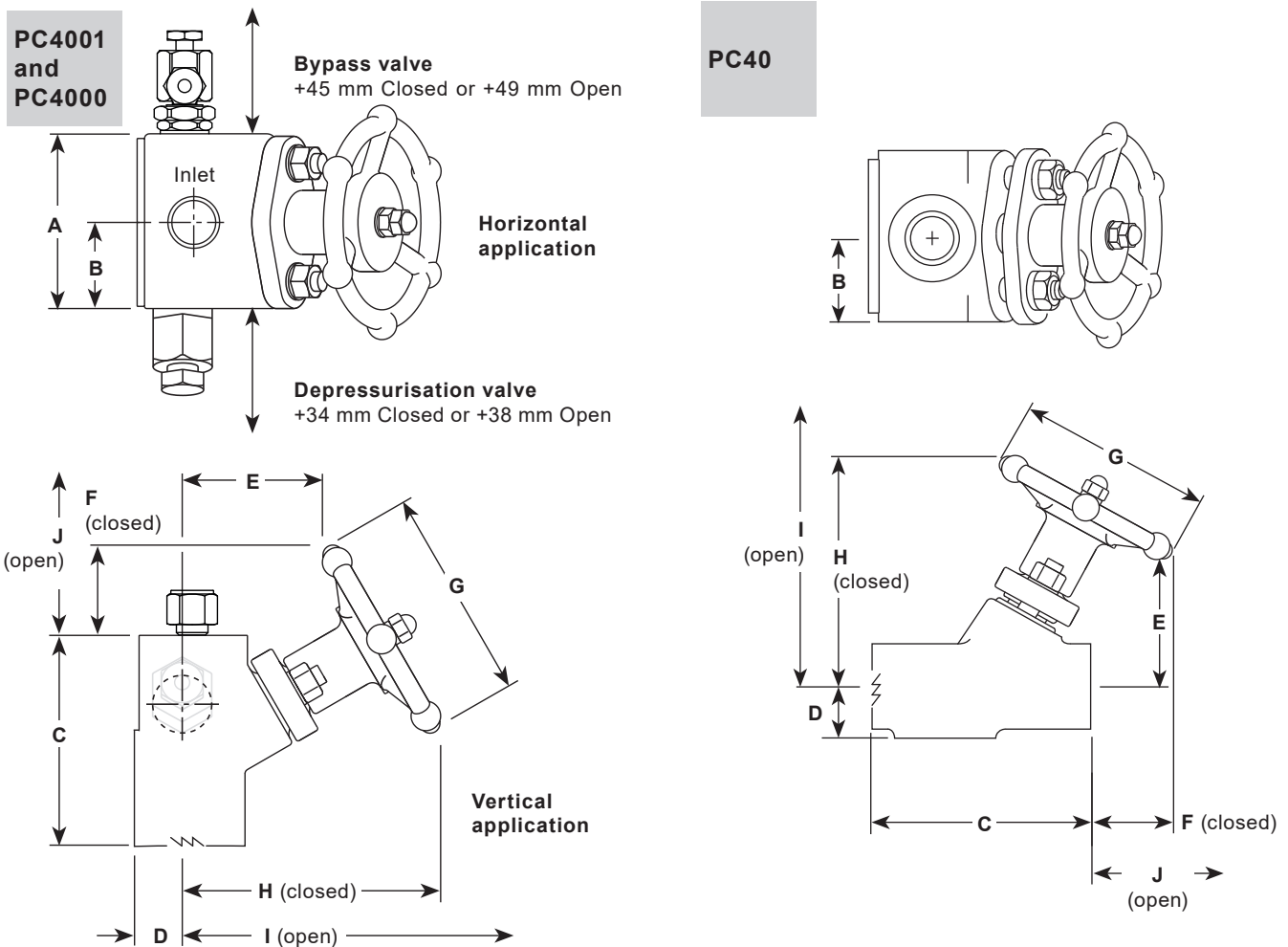

Safety information, installation and maintenance

For full details see the Installation and Maintenance Instructions (IM-IBR128-35) supplied with the product.

General information

There are two criteria which must be satisfied to ensure that the swivel connector trap will operate correctly and ensure effective condensate removal:

1. The PC4001, PC4000 and PC40 shall be installed with flow in the direction of the arrow on connector body. Flow can be horizontal (left to right or right to left), vertical or inclined.
2. The connection face for the swivel connector steam trap must be in the vertical plane unless stated on relevant steam trap Installation and Maintenance Instructions.

After installation it is recommended that the pipeline connector is insulated to minimise radiated heat losses and to protect personnel from burns risk: Please note that some steam trap types should not be insulated.

Depressurisation and line drainage

The PC4001 and PC4000 assemblies are supplied fitted with valves which allow depressurisation of the system to enable safe removal and maintenance of the steam trap. The PC4001 is also supplied with bypass/line drainage fitted, however consideration must be given to the position of the discharge which should be directed or piped to a safe place where it will not injure personnel or damage equipment. PC40 only - Following isolation slightly loosen the trap bolts to ensure the full release of hot steam and condensate prior to commencing work. Safety equipment should be used and care taken to avoid potential injury.

Disposal

This product is recyclable. No ecological hazard is anticipated with the disposal of this product, providing due care is taken.

Spare parts

The spare parts available are shown in heavy outline. Parts drawn in grey line are not supplied as spares. For ease of replacement an extractor tool is available for removing the sealing rings.

Available spares



Sealing ring set	8 and 9
Piston valve assembly	2, 4, 5, 6, 7, 8, 9, 10, 11 and 12
Piston valve sub-assembly	6, 7, 8 and 9
Extractor tool	Not shown
PC depressurisation valve and gasket	14 and 20
PC bypass valve assembly and gasket	15, 16, 17, 18, 19, 21, 22, 23 and 20
Strainer screen and gasket (pack of 3)	24 and 20
Valve gasket set (pack of 10)	20

How to order spares

Always order spares by using the description given in the column headed 'Available spares' and state type and size of equipment.

Example: 1 off Sealing ring set for an integral piston valve on a PC4001 pipeline connector having DN15 socket weld connections.

Recommended tightening torques

Item		or mm		N m
4	14		5/16" x 18 UNC	12.0
11	10		M6	12.0
14 and 23	24		M18	74 - 78
21	27		M14	45-50

