

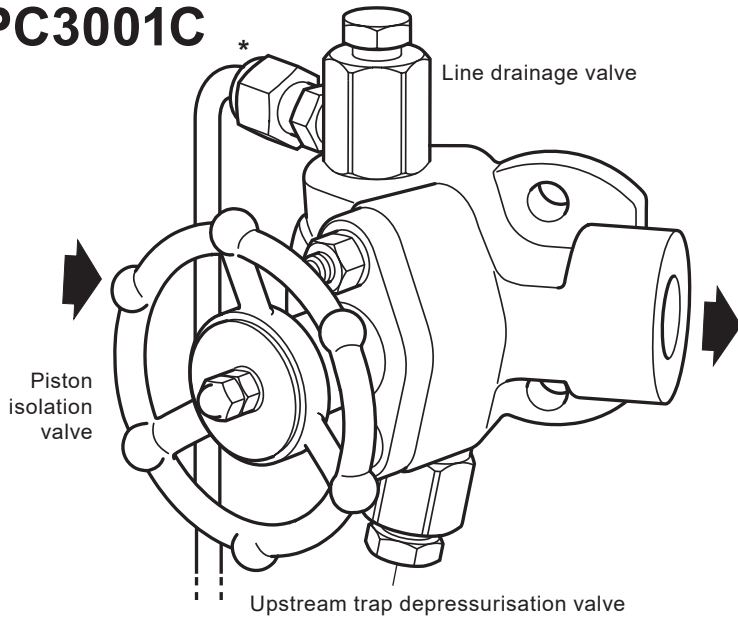

# PC3001C and PC3000C Pipeline Connectors For the Oil & Gas Industry

## PC3001C



\* **Please note** that the line drain outlet is shown out of position for clarity and that the line drain pipework is to be supplied by the customer.

## PC3000C

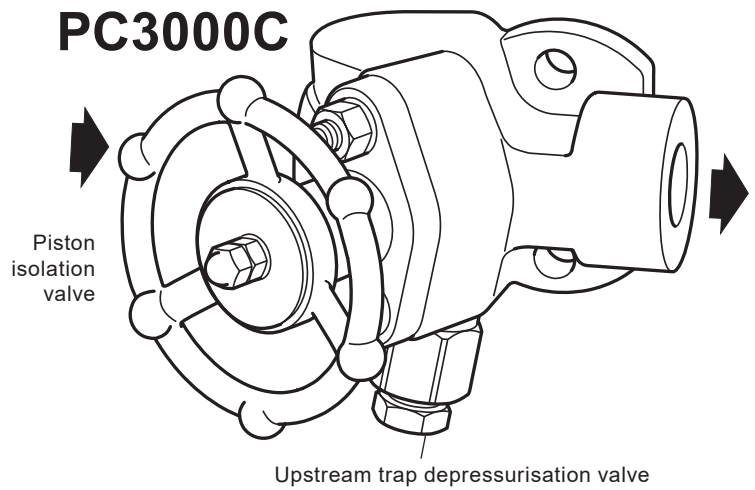



## Description

The PC3001C and PC3000C range of pipeline connectors are designed for use with two bolt universal swivel connector steam traps. Incorporating one integral piston stop valve it is possible to isolate upstream of the steam trap.

### PC3001C and PC3000 models only

The trap depressurisation port also incorporates a maintainable 40 mesh stainless steel strainer screen to provide trap protection from system dirt and debris. The PC3001C is also fitted with a line drainage valve upstream of the isolation valve.

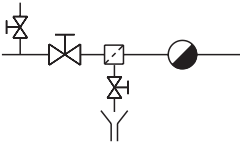
## Available types

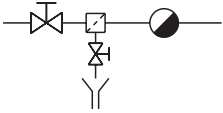
Model	Valve connections	P and ID diagram	Flow direction
<b>PC3001C</b>	1 x Piston isolation valves 1 x Upstream trap depressurisation valve 1 x Line drain valve		Left to right  or  Right to left
<b>PC3000C</b>	1 x Piston isolation valves 1 x Upstream trap depressurisation valve		

For available options to the pipeline connections detailed within this Technical Information sheet please reference TI-F01-37.

**Standards** - These products fully comply with the requirements of the Indian Boiler Regulations, 1950.

**Note:** All certification/inspection requirements must be stated at the time of order placement. For other certification contact Spirax Sarco.

## Sizes and pipe connections

DN15 and DN20 condensate inlet / outlet connections are available with screwed BSP or NPT and as a socket weld connection to ASME B16.11 class 3000. Drainage and venting connections have an M18 thread as standard.

Flanged versions are also available upon request. Please contact Spirax Sarco for further details.

## How to order

Example: 1 off ½" Spirax Sarco PC3001C pipeline connector having right to left flow and socket weld end connections to ASME B 16.11 Class 3000.

## Materials

No. Part	Material	
1 Pipeline connector body	Carbon steel	A105 / A350 LF2
2 Bonnet	Carbon steel (Zinc plated)	ASTM A105N / LF2
3 Studs	Steel (plated)	ASTM A193 B7
4 Nuts	Steel (plated)	ASTM A194 2H
5 Washers	Stainless steel	
6 Piston	Stainless steel	AISI 410 : 1.4006
7 Lantern bush	Stainless steel	ASTM A276 : AISI 431
8 Upper ring	Graphite and stainless steel	
9 Lower ring	Graphite and stainless steel	
10 Handwheel	Carbon steel (Zinc plated)	EN 10213 : 1.0619N
11 Handwheel nuts	Stainless steel	
12 Washers	Steel	
13 Name-plate	Stainless steel	
14 Depressurisation valve	Stainless steel	ASTM A182 : 304 / 304L
15 Line drain valve	Stainless steel	ASTM A182 : 304 / 304L
16 Valve screw	Stainless steel	ASTM A276 : AISI 431
17 Valve cone	Stainless steel	AISI 440 B
18 Retaining ring	Stainless steel	BS 2056 302 S26
19 Compression fitting for the line drain valve only	Carbon steel (Zinc plated)	
20 Valve gasket	Graphite and stainless steel	
21 Strainer screen	Stainless steel	
22 Depressurisation valve gasket	Graphite	

View showing valve internals

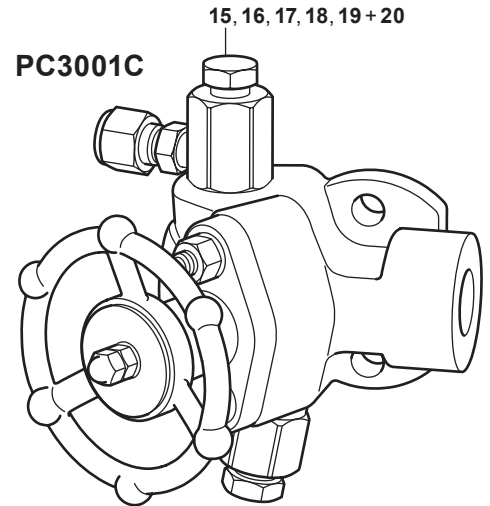
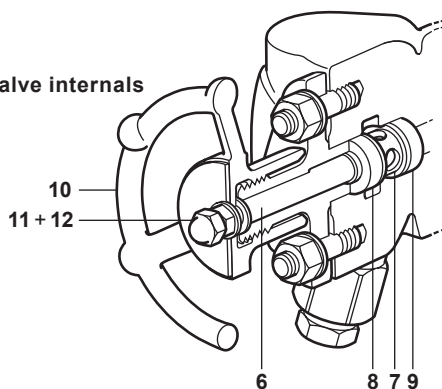

**Please note** The PC3001C and PC3000C unit is supplied fully assembled; the view is only exploded for ease of part identification.

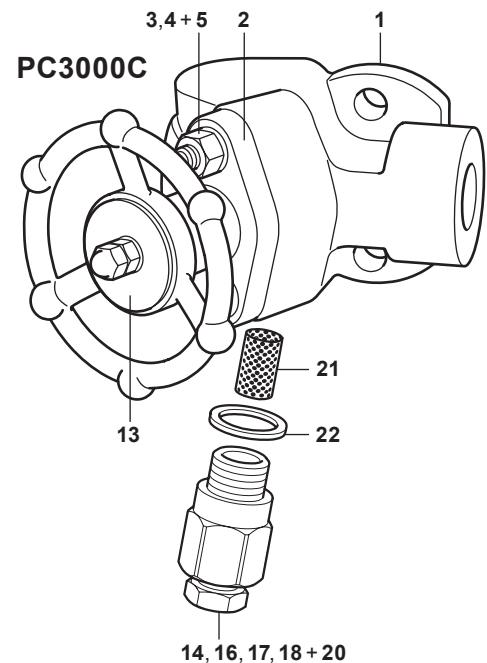

## Pressure / temperature limits (ISO 6552)

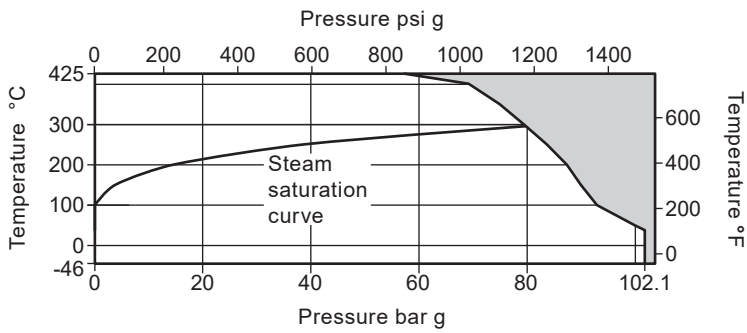

The product **must not** be used in this region or beyond the parameter of the PMA or TMA of the relative end connection - See notes below.

Body design condition			ASME 600
PMA	Maximum allowable pressure	102.1 bar g @ 38 °C	1480 psi g @ 100 °F
TMA	Maximum allowable temperature	425 °C @ 57.5 bar g	797 °F @ 833 psi g
	Minimum allowable temperature	-46 °C	-51 °F
PMO	Maximum operating pressure for saturated steam service	79.6 bar g @ 300 °C	1 154.5 psi g @ 572 °F
TMO	Maximum operating temperature	425 °C @ 57.5 bar g	797 °F @ 833 psi g
	Minimum operating temperature	-46 °C	-51 °F
Designed for a maximum cold hydraulic test pressure of:			153.2 bar g / 2 221.9 psi g

### Notes:

1. If flange connections are fitted then these will limit the maximum and minimum design conditions of the pipeline connector.
2. The maximum operating limits of the complete assembly will be dictated by the steam trap of choice. Reference the specific steam trap technical information sheet for its 'Pressure/temperature limits'.

## Dimensions / weight (approximate)

Units	A	B	C	D	E	F	G	H	I	J	Weight
Metric mm	72	36	90	25	50	35	90	99	115	50	3.6 kgs
Imperial inches	2.8"	1.4"	3.5"	1"	2"	1.4"	3.5"	3.9"	4.53"	1.97"	7.9 lbs

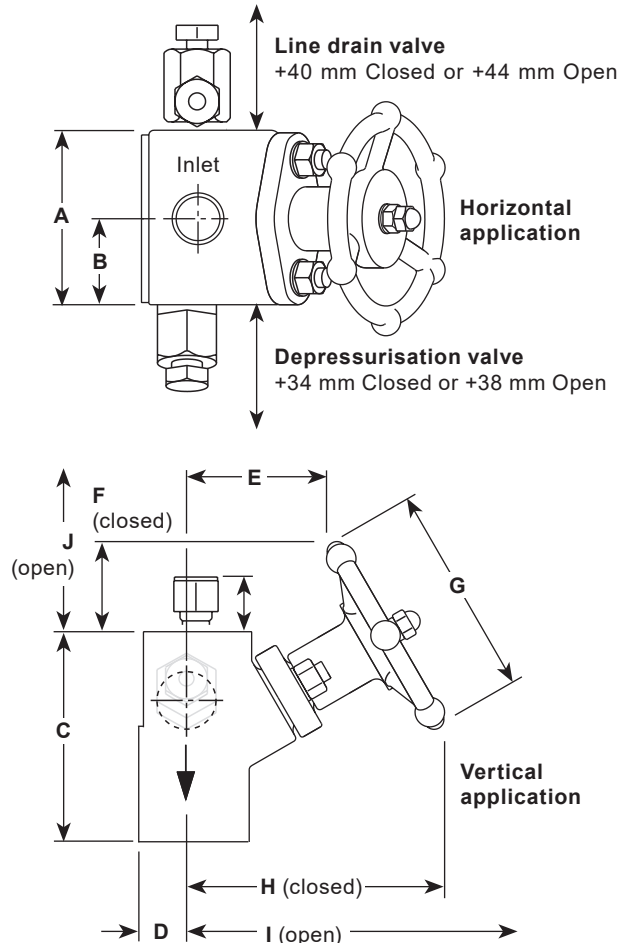

## Safety information, installation and maintenance

For full details see the Installation and Maintenance Instructions supplied with the product.

### General information

There are two criteria which must be satisfied to ensure that the swivel connector trap will operate correctly and ensure effective condensate removal:

1. The PC3001C and PC3000C and shall be installed with flow in the direction of the arrow. Flow can be horizontal (left to right or right to left), vertical or inclined.
2. The connection face for the swivel connector steam trap must be in the vertical plane unless stated on relevant steam trap Installation and Maintenance Instructions.

After installation it is recommended that the pipeline connector is insulated to minimise radiated heat losses and to protect personnel from burns risk: Please note that some steam trap types should not be insulated.

### Depressurisation and line drainage

The PC3001C and PC3000C assemblies are supplied fitted with valve(s) which allow depressurisation of the system to enable safe removal and maintenance of the steam trap. The PC3001C is also supplied with line drainage fitted, however consideration must be given to the position of the discharge which should be directed or piped to a safe place where it will not injure personnel or damage equipment.

### Disposal

This product is recyclable. No ecological hazard is anticipated with the disposal of this product, providing due care is taken.

## Spare parts

The spare parts available are shown in heavy outline. Parts drawn in grey line are not supplied as spares. For ease of replacement an extractor tool is available for removing the sealing rings.

### Available spares



Sealing ring set	8 and 9
Piston valve assembly	2, 4, 5, 6, 7, 8, 9, 10, 11 and 12
Piston valve sub-assembly	6, 7, 8 and 9
Extractor tool	Not shown
PC depressurisation valve and gasket	14 and 22
PC line drain valve and gasket	15 and 22
Strainer screen and gasket (pack of 3)	21 and 22
Valve gasket set (pack of 10)	22

### How to order spares

Always order spares by using the description given in the column headed 'Available spares' and state type and size of equipment.

**Example:** 1 off Sealing ring set for an integral piston valve on a PC3001C pipeline connector having DN15 socket weld connections.

## Recommended tightening torques

Item	 or mm		N m
4	14	5/16" x 18 UNC	12.0
11	10	M6	12.0
14 and 15	24	M18	74 - 78

