

## PV4 and PV6 Piston Valves

### Installation and Maintenance Instructions

---

---

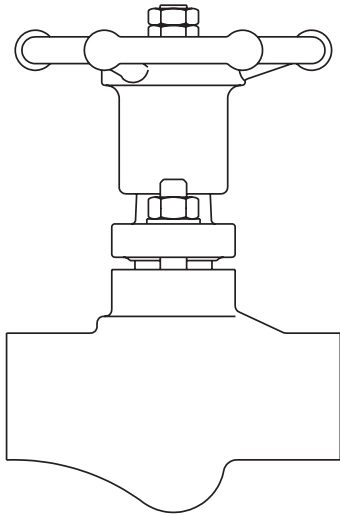

1. Safety information
2. General product information
3. Installation
4. Commissioning
5. Operation
6. Maintenance
7. Spare parts



# 1. Safety information

Safe operation of these products can only be guaranteed if they are properly installed, commissioned, used and maintained by qualified personnel (see Section 1.11) in compliance with the operating instructions. General installation and safety instructions for pipeline and plant construction, as well as the proper use of tools and safety equipment must also be complied with.

## 1.1 Intended use

Referring to the Installation and Maintenance Instructions, name-plate and Technical Information Sheet, check that the product is suitable for the intended use / application. The products listed below comply with the requirements of the Indian Boiler Regulations, 1950

- i) The PV4 has been specifically designed for use on steam, air or condensate. The PV4 and PV6 range have been designed for use on steam, air and water / condensate. The products' use on other fluids may be possible but, if this is contemplated, Spirax Sarco should be contacted to confirm the suitability of the product for the application being considered.
- ii) Check material suitability, pressure and temperature and their maximum and minimum values. If the maximum operating limits of the product are lower than those of the system in which it is being fitted, or if malfunction of the product could result in a dangerous overpressure or overtemperature occurrence, ensure a safety device is included in the system to prevent such over-limit situations.
- iii) A number of products are supplied for the intention of the end user (or agent thereof) modifying the flange configuration from that supplied. It is the responsibility of the organisation carrying out the modification to do so in accordance with the internationally recognised flange standards and to ensure that the design rating and operation of the product are not compromised. Spirax Sarco will not be held responsible for any unapproved modification or consequential liability resulting in failure to observe these requirements.
- iv) Determine the correct installation situation and direction of fluid flow.
- v) Spirax Sarco products are not intended to withstand external stresses that may be induced by any system to which they are fitted. It is the responsibility of the installer to consider these stresses and take adequate precautions to minimise them.
- vi) Remove protection covers from all connections and protective film from all name-plates, where appropriate, before installation on steam or other high temperature applications.

## 1.2 Access

Ensure safe access and if necessary a safe working platform (suitably guarded) before attempting to work on the product. Arrange suitable lifting gear if required.

## 1.3 Lighting

Ensure adequate lighting, particularly where detailed or intricate work is required.

## **1.4 Hazardous liquids or gases in the pipeline**

Consider what is in the pipeline or what may have been in the pipeline at some previous time. Consider: flammable materials, substances hazardous to health, extremes of temperature.

## **1.5 Hazardous environment around the product**

Consider: explosion risk areas, lack of oxygen (e.g. tanks, pits), dangerous gases, extremes of temperature, hot surfaces, fire hazard (e.g. during welding), excessive noise, moving machinery.

## **1.6 The system**

Consider the effect on the complete system of the work proposed. Will any proposed action (e.g. closing isolation valves, electrical isolation) put any other part of the system or any personnel at risk?

Dangers might include isolation of vents or protective devices or the rendering ineffective of controls or alarms. Ensure isolation valves are turned on and off in a gradual way to avoid system shocks.

## **1.7 Pressure systems**

Ensure that any pressure is isolated and safely vented to atmospheric pressure. Consider double isolation (double block and bleed) and the locking or labelling of closed valves. Do not assume that the system has depressurised even when the pressure gauge indicates zero.

## **1.8 Temperature**

Allow time for temperature to normalise after isolation to avoid the danger of burns.

## **1.9 Tools and consumables**

Before starting work ensure that you have suitable tools and/or consumables available. Use only genuine Spirax Sarco replacement parts.

## **1.10 Protective clothing**

Consider whether you and/or others in the vicinity require any protective clothing to protect against the hazards of, for example, chemicals, high/low temperature, radiation, noise, falling objects, and dangers to eyes and face.

## **1.11 Permits to work**

All work must be carried out or be supervised by a suitably competent person. Installation and operating personnel should be trained in the correct use of the product according to the Installation and Maintenance Instructions.

Where a formal 'permit to work' system is in force it must be complied with. Where there is no such system, it is recommended that a responsible person should know what work is going on and, where necessary, arrange to have an assistant whose primary responsibility is safety.

Post 'warning notices' if necessary.

## **1.12 Handling**

Manual handling of large and/or heavy products may present a risk of injury. Lifting, pushing, pulling, carrying or supporting a load by bodily force can cause injury particularly to the back. You are advised to assess the risks taking into account the task, the individual, the load and the working environment and use the appropriate handling method depending on the circumstances of the work being done.

## **1.13 Residual hazards**

In normal use the external surface of the product may be very hot. If used at the maximum permitted operating conditions the surface temperature of some products may reach temperatures in excess of 425 °C (797 °F) for PV4 and 538 °C (1000 °F) for PV6.

Many products are not self-draining. Take due care when dismantling or removing the product from an installation (refer to 'Maintenance instructions').

## **1.14 Freezing**

Provision must be made to protect products which are not self-draining against frost damage in environments where they may be exposed to temperatures below freezing point.

## **1.15 Disposal**

Unless otherwise stated in the Installation and Maintenance Instructions, this product is recyclable and no ecological hazard is anticipated with its disposal providing due care is taken.

## **1.16 Returning products**

Customers and stockists are reminded that under EC Health, Safety and Environment Law, when returning products to Spirax Sarco they must provide information on any hazards and the precautions to be taken due to contamination residues or mechanical damage which may present a health, safety or environmental risk. This information must be provided in writing including Health and Safety data sheets relating to any substances identified as hazardous or potentially hazardous.

# 2. General product information

## 2.1 General description

The PV4 and PV6 are piston isolation valves that have been designed for use on steam, condensate and other liquid systems.

### Available types:

Screwed, butt weld and socket weld connections	<b>PV4</b>	Carbon steel body/bonnet and stainless steel internals
	<b>PV6</b>	Stainless steel body/bonnet and internals

### Standards

This product fully complies with the requirements of the Indian Boiler Regulations, 1950.

**Note:** All certification/inspection requirements must be stated at the time of order placement.

**Note:** For further data regarding the PV range see Technical Information sheet TI-IBR-P174-02-EN-ISS1.

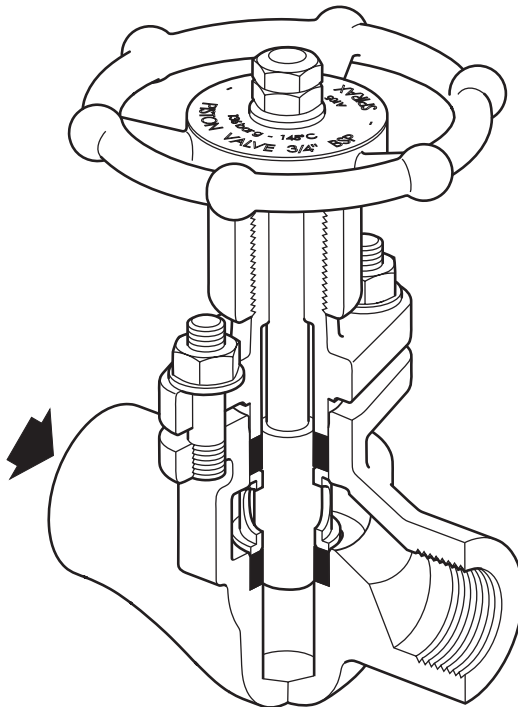
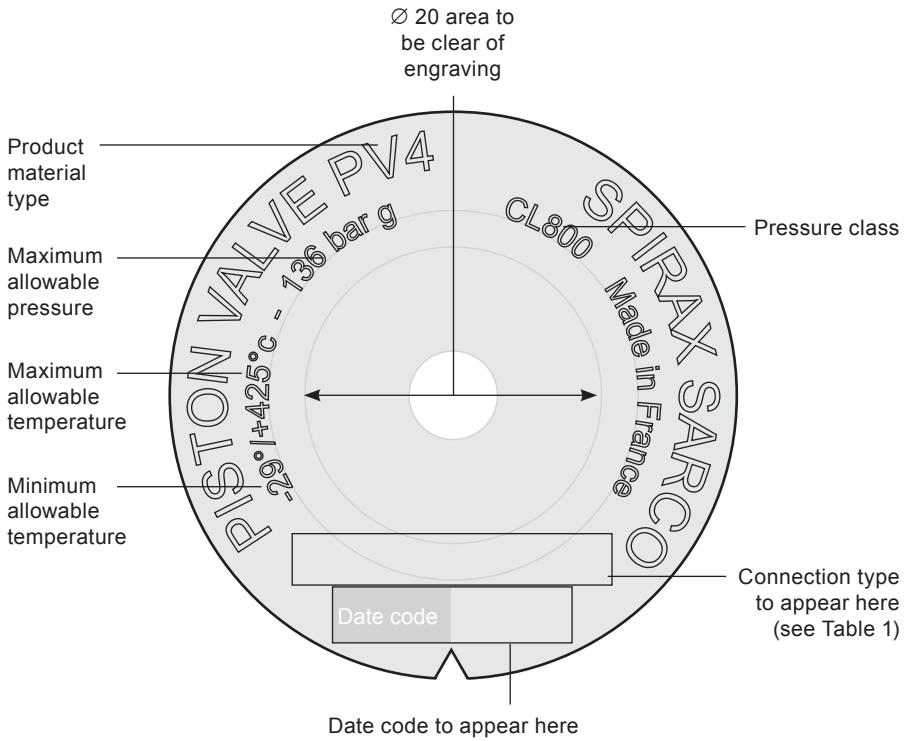

Fig. 1 PV with screwed connections



**Fig. 2 Name plate**

## 2.2 Sizes and pipe connections

½", ¾", 1", 1¼", 1½" and 2"

Butt welded ends to EN 12627:1999BW - ASME B16.25

Screwed BSP (BS 21 / DIN 2999) or NPT to (ASME B1.20.1)

Socket weld ends to ASME B 16.11

## 2.3 PV4 Pressure / temperature limits

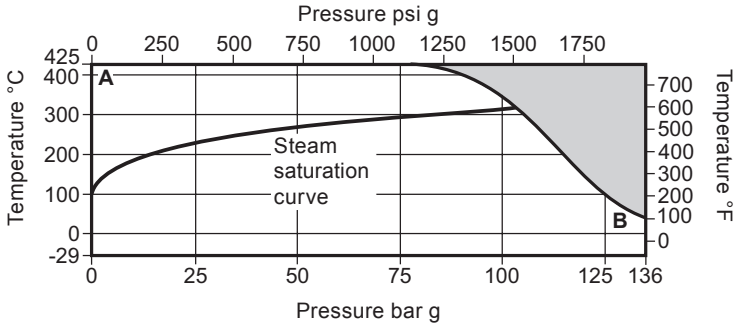

The product **must not** be used in this region.

**A - B** Screwed, socket weld and butt weld

Body design conditions		API Class 800	
PMA	Maximum allowable pressure	136 bar g @ 38 °C	(1 972.5 psi g @ 100 °F)
TMA	Maximum allowable temperature	425 °C @ 76 bar g	(797 °F @ 1 102 psi g)
Minimum allowable temperature		-29 °C	(-20 °F)
PMO	Maximum operating pressure for saturated steam service	101 bar g	(1465 psi g)
TMO	Maximum operating temperature	425 °C @ 76 bar g	(797 °F @ 1 102 psi g)
Minimum operating temperature		-29 °C	(-20 °F)
<b>Note:</b> For lower operating temperatures consult Spirax Sarco			
Designed for a maximum cold hydraulic test pressure:		204 bar g	(2958.8 psi g)



## 2.4 PV6 Pressure / temperature limits

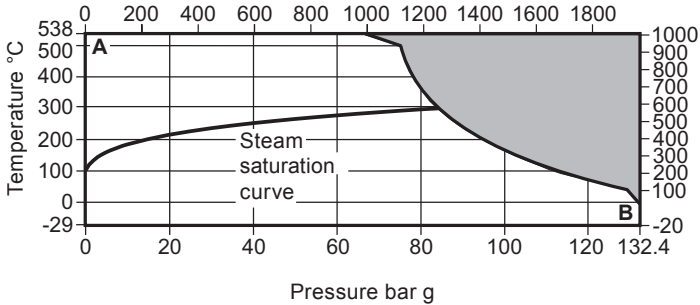

The product **must not** be used in this region.

**A - B** Screwed, socket weld and butt weld

Body design conditions		API Class 800
PMA	Maximum allowable pressure	132 bar g @ 0 °C (1 914.5 psi g @ 32 °F)
TMA	Maximum allowable temperature	538 °C @ 67 bar g (1 000.4 °F @ 971.7 psi g)
	Minimum allowable temperature	-29 °C (-20 °F)
PMO	Maximum operating pressure for saturated steam service	84 bar g (1 218 psi g)
TMO	Maximum operating temperature	538 °C @ 67 bar g (1 000.4 °F @ 971.7 psi g)
	Minimum operating temperature	-29 °C (-20 °F)
<b>Note:</b> For lower operating temperatures consult Spirax Sarco		
Designed for a maximum cold hydraulic test pressure:		198 bar g (2 871.8 psi g)

# 3. Installation

Note: Before actioning any installation observe the 'Safety information' in Section 1.



The valve can be installed from the vertical to the horizontal plane.

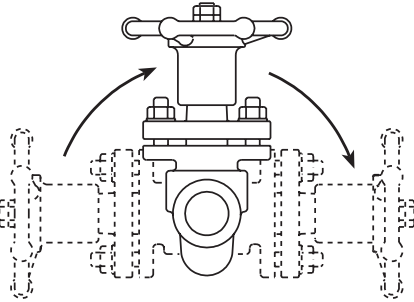

The valve can be installed in vertical pipework.

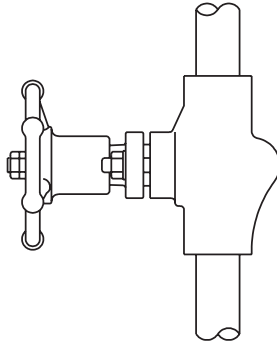

The preferred orientation for installation.

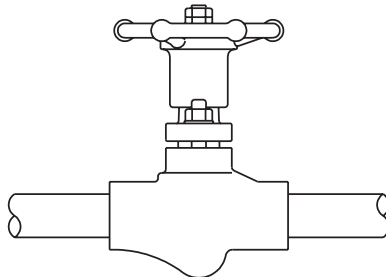
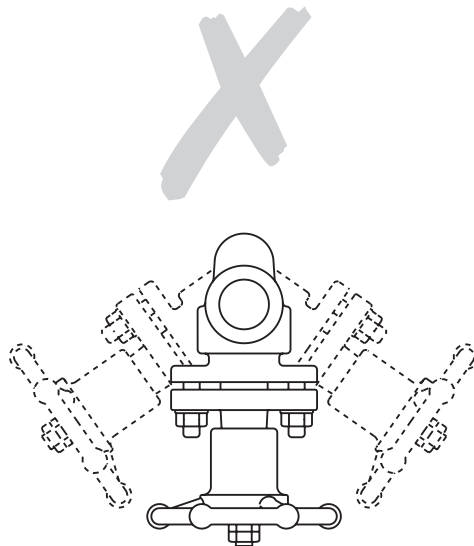

Fig. 3 Correct orientation for installation

- 3.1 Install the valve in the direction of flow given by the arrow on the body. The preferred position is with the spindle vertical. The valve can be installed from the vertical to the horizontal plane (see Figure 3 opposite). **Do not mount the valve upside down (Figure 4).**
- 3.2 Wherever practicable, valves should be installed where there is adequate space available so that they can be conveniently operated and maintained.
- 3.3 Before installing a valve, check to ensure that the size, pressure rating, materials of construction, end connections, etc. are suitable for the service conditions of the particular application. Remove any plastic plugs from the ports.
- 3.4 Care must be taken to ensure that all dirt which may have accumulated in the valve during storage is removed before installation: maintain cleanliness during installation since the introduction of dirt can result in damage to the valve seats and operating mechanism.
- 3.5 When a socket weld valve is being installed the welding should be carried out to an approved procedure to a recognised standard. During welding the valve should be in the open position to allow maximum heat dissipation.
- 3.6 Ensure that the discharged flow is directed to a safe place.



**Fig. 4 Incorrect orientation for installation**

# 4. Commissioning

After installation or maintenance ensure that the system is fully functioning. Carry out tests on any alarms or protective devices.

# 5. Operation

The Spirax Sarco PV4 and PV6 piston valves are operated manually by a handwheel. Special care must be taken to ensure that the movement is made in the correct direction; **Anticlockwise** to open - **Clockwise** to close.

To open the valve fully, turn the handwheel until the shaft is raised to the maximum position, then turn the handwheel clockwise a ¼ turn to remove any backlash. This is to prevent the possibility of attempting to force open a valve, which is already fully open, resulting in damage to the stem or other components.

Due to the unique design of the piston valve it is fully closed as soon as the piston engages into the lower sealing rings. Therefore there is no need to continue closing the valve until the spindle movement stops.

**Note:** The valve spindle should be periodically checked (typically 12 months) to ensure adequate grease is present to ensure efficient valve operation. Grease such as 'Never Seize' is recommended. When fitted on high temperature applications or where severe weather conditions prevail, the grease should be checked more regularly.

**Important:** The use of a valve key is therefore not recommended or required. If the handwheel is overtightened, damage to the valve internals may occur.

# 6. Maintenance

**Note:** Before actioning any maintenance programme observe the 'Safety information' in Section 1.

## 6.1 General information

As with all mechanical devices, regular maintenance is the most efficient means of ensuring continued operational efficiency.

Regular scheduled inspection of all valves is essential especially on valves which are operated only occasionally. With a piston valve, the bonnet must be tightened down to prevent stem gland seal leaks. Applying the recommended torque (see Table 1) to nut (10) will ensure any steam leaks are avoided.

The piston valve is designed for either bonnet assembly replacement which includes all the necessary internal parts, or simple in-line replacement of the upper and lower sealing rings.

**Note:** The valve spindle should be periodically checked (typically 12 months) to ensure adequate grease is present to ensure efficient valve operation. Grease such as 'Never Seize' is recommended. When fitted on high temperature applications or where severe weather conditions prevail, the grease should be checked more regularly.

## 6.2 How to replace the bonnet assembly and sealing rings:

- Close the piston valve.
- Remove the 2 x bonnet nuts (10) and 2 x washers (13).
- Withdraw the bonnet (2) complete with the piston (6).
- Remove the upper sealing rings (4), lantern bush (5) and lower sealing ring (3).
- Ensure the inside surfaces of the valve are clean.
- Refit the new lower sealing ring (2), lantern bush (4) and the upper sealing ring (3).
- Refit the bonnet (2) complete with the piston (6) and tighten the bonnet nuts (10) to the recommended torque (see Table 1).

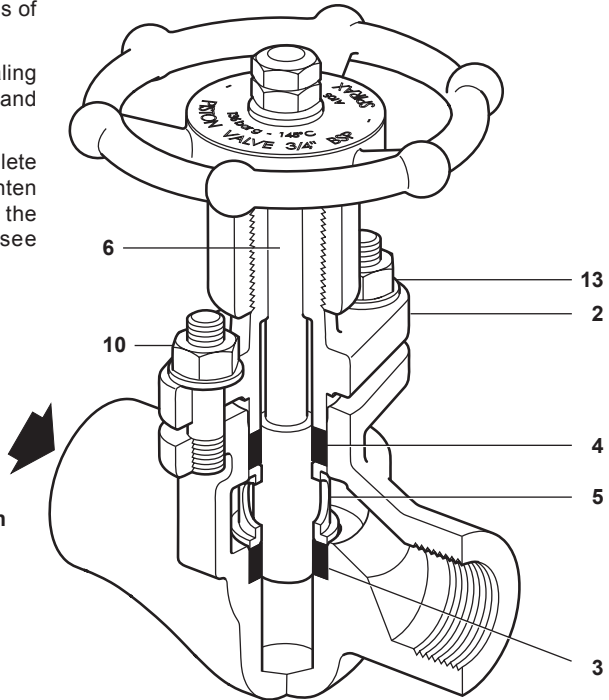



Fig. 5 PV4 (screwed) shown

Table 1 Recommended tightening torques

Item	Size		or mm		N m	(lbf ft)
10	1/2"	13 A/F			12	(9)
	3/4"	13 A/F			9	(7)
	1"	13 A/F			9	(7)
	1 1/4"	17 A/F			30	(22)
	1 1/2"	22 A/F			35	(26)
	2"	26 A/F			70	(52)

**Caution:** The torque of the studs is calculated to optimise the use of the product. An excessive torque can damage the valve internals (particularly if the product is open). The studs of valve can be retightened to extend the life of it, but only when it is closed and not more than the recommended torque.

# 7. Spare parts

Spare parts are available as indicated below. No other parts are supplied as spares.

## Available spares

Set of sealing rings	3 and 4
Bonnet assembly	2, 3, 4, 5, 6, 7, 8 and 11

## How to order spares

Always order spares by using the description given in the column headed 'Available spares' and state the size and type of valve.

**Example:** 1 - Bonnet assembly for a 1/2" Spirax Sarco PV4 (screwed) piston valve.

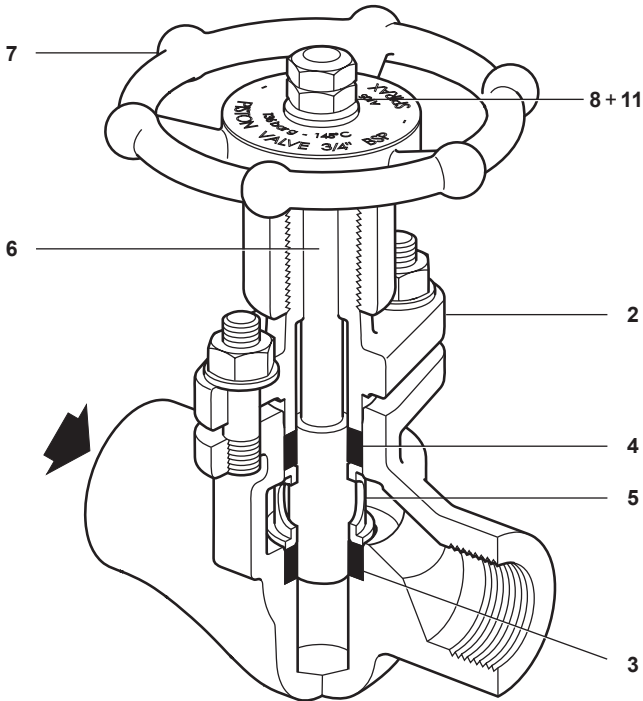

Fig. 6 PV4 and PV6 (screwed) shown



