

PC10HP
Pipeline Connector (ASME 600)
Installation and Maintenance Instructions

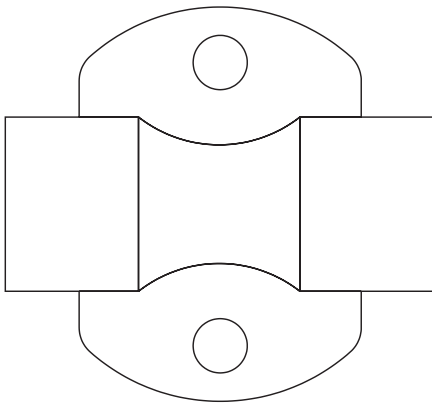

1. Safety information
2. General product information
3. Installation
4. Commissioning
5. Spare parts and Maintenance

1. Safety information

Safe operation of these products can only be guaranteed if they are properly installed, commissioned, used and maintained by qualified personnel (see Section 1.11) in compliance with the operating instructions. General installation and safety instructions for pipeline and plant construction, as well as the proper use of tools and safety equipment must also be complied with.

1.1 Intended use

Referring to the Installation and Maintenance Instructions, product markings and Technical Information Sheet, check that the product is suitable for the intended use/application. These products comply with the Indian Boiler Regulations, 1950.

- i) These products have been specifically designed for use on steam, air or condensate/water. The products' use on other fluids may be possible but, if this is contemplated, Spirax Sarco should be contacted to confirm the suitability of the product for the application being considered.
- ii) Check material suitability, pressure and temperature and their maximum and minimum values. If the maximum operating limits of the product are lower than those of the system in which it is being fitted, or if malfunction of the product could result in a dangerous overpressure or overtemperature occurrence, ensure a safety device is included in the system to prevent such over-limit situations.
- iii) Determine the correct installation situation and direction of fluid flow.
- iv) Spirax Sarco products are not intended to withstand external stresses that may be induced by any system to which they are fitted. It is the responsibility of the installer to consider these stresses and take adequate precautions to minimise them.
- v) Remove protection covers from all connections, where appropriate, before installation on steam or other high temperature applications.

1.2 Access

Ensure safe access and if necessary a safe working platform (suitably guarded) before attempting to work on the product. Arrange suitable lifting gear if required.

1.3 Lighting

Ensure adequate lighting, particularly where detailed or intricate work is required.

1.4 Hazardous liquids or gases in the pipeline

Consider what is in the pipeline or what may have been in the pipeline at some previous time. Consider: flammable materials, substances hazardous to health, extremes of temperature.

1.5 Hazardous environment around the product

Consider: explosion risk areas, lack of oxygen (e.g. tanks, pits), dangerous gases, extremes of temperature, hot surfaces, fire hazard (e.g. during welding), excessive noise, moving machinery.

1.6 The system

Consider the effect on the complete system of the work proposed. Will any proposed action (e.g. closing isolation valves, electrical isolation) put any other part of the system or any personnel at risk?

Dangers might include isolation of vents or protective devices or the rendering ineffective of controls or alarms. Ensure isolation valves are opened and closed progressively to avoid system shocks.

1.7 Pressure systems

Ensure that any pressure is isolated and safely vented to atmospheric pressure. Consider double isolation (double block and bleed) and the locking or labelling of closed valves. Do not assume that the system has depressurised even when the pressure gauge indicates zero.

1.8 Temperature

Allow time for temperature to normalise after isolation to avoid the danger of burns.

1.9 Tools and consumables

Before starting work ensure that you have suitable tools and/or consumables available. Use only genuine Spirax Sarco replacement parts.

1.10 Protective clothing

Consider whether you and/or others in the vicinity require any protective clothing to protect against the hazards of, for example, chemicals, high /low temperature, radiation, noise, falling objects, and dangers to eyes and face.

1.11 Permits to work

All work must be carried out or be supervised by a suitably competent person. Installation and operating personnel should be trained in the correct use of the product according to the Installation and Maintenance Instructions.

Where a formal 'permit to work' system is in force it must be complied with. Where there is no such system, it is recommended that a responsible person should know what work is going on and, where necessary, arrange to have an assistant whose primary responsibility is safety.

Post 'warning notices' if necessary.

1.12 Handling

Manual handling of large and/or heavy products may present a risk of injury. Lifting, pushing, pulling, carrying or supporting a load by bodily force can cause injury particularly to the back. You are advised to assess the risks taking into account the task, the individual, the load and the working environment and use the appropriate handling method depending on the circumstances of the work being done.

1.13 Residual hazards

In normal use the external surface of the product may be very hot. If used at the maximum permitted operating conditions the surface temperature may reach temperatures in excess of 425°C (797°F).

Many products are not self-draining. Take due care when dismantling or removing the product from an installation (refer to 'Maintenance instructions').

1.14 Freezing

Provision must be made to protect products which are not self-draining against frost damage in environments where they may be exposed to temperatures below freezing point.

1.15 Disposal

Unless otherwise stated in the Installation and Maintenance Instructions, this product is recyclable and no ecological hazard is anticipated with its disposal providing due care is taken.

1.16 Returning products

Customers and stockists are reminded that under EC Health, Safety and Environment Law, when returning products to Spirax Sarco they must provide information on any hazards and the precautions to be taken due to contamination residues or mechanical damage which may present a health, safety or environmental risk. This information must be provided in writing including Health and Safety data sheets relating to any substances identified as hazardous or potentially hazardous.

2. General product information

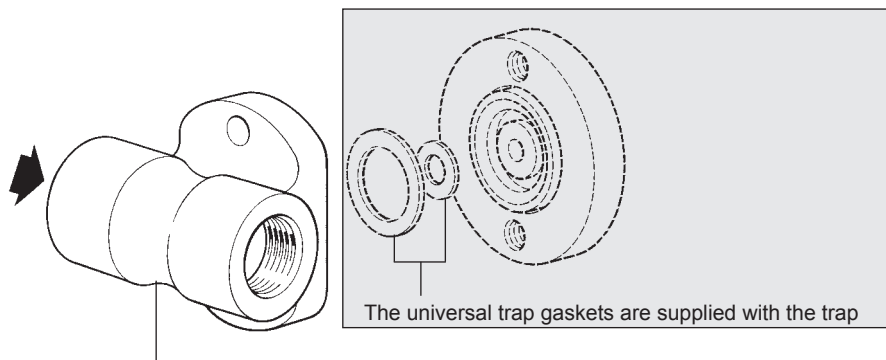

Fig. 1 The PC10HP has been designed for use with the above listed steam trap options

2.1 General description

The PC10HP pipeline connector is designed for use with the above listed swivel connector steam traps up to the maximum pressure/temperature limitations of the selected steam trap. The connector can be fitted into any vertical or horizontal pipeline and the trap can also be rotated through 360° to ensure their correct orientation for operation.

The principle is that the pipeline connector can be fitted into the pipeline without the trap fitted and the trap is connected afterwards using just two bolts. The trap can be simply and quickly removed / replaced to minimise system downtime and reduce maintenance resource.

Standards

These products fully comply with the requirements of the Indian Boiler Regulations, 1950.

Certification

This product is available with IBR certification and a manufacturers Typical Test Report.

Note: All certification / inspection requirements must be stated at the time of order placement.

Note: For additional information see the following Technical Information sheet TI-IBR16-01IN.

2.2 Sizes and pipe connections

Condensate inlet/outlet DN15, DN20 and DN25

½", ¾" and 1" screwed BSP or NPT

Socket weld ends to ASME B 16.11/BS 3799 Class 3000.

2.3 K_v values

Size	DN15	DN20	DN25
K _v	1.1	1.1	1.1

For conversion: C_V (UK) = $K_V \times 0.963$ C_V (US) = $K_V \times 1.156$

2.4 Pressure / temperature limits (ISO 6552)

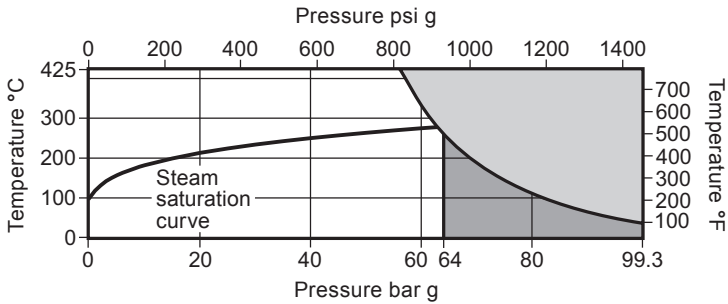

The product **must not** be used in this region.

For optimum performance the PMO should not exceed 64 bar g

The maximum operating limits of the complete assembly will be dictated by the steam trap of choice. Reference the specific steam trap Technical Information sheet for its maximum pressure / temperature limitations.

Body design conditions		ASME Class 600	
TMA	Maximum allowable temperature	425°C @ 56 bar g	(797°F @ 812 psi g)
	Minimum allowable temperature	0°C	(32°F)
PMO	Maximum operating pressure for saturated steam service	64 bar g @ 281°C	(928 psi g @ 538°F)
TMO	Maximum operating temperature	425°C @ 56 bar g	(797°F @ 812 psi g)
	Minimum operating temperature	0°C	(32°F)
Note: For lower operating temperatures consult Spirax Sarco			
PMOB	Maximum operating backpressure should not exceed 80% of the upstream pressure		
Designed for a maximum cold hydraulic test pressure of		149 bar g	(2161 psi g)

2.5 Dimensions / weights (approximate) in mm and kg

Size	A	Weight
1/2"	61.5	0.6
3/4"	73.5	0.7
1"	90.0	0.7

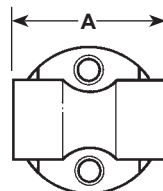

3. Installation

Note: Before actioning any installation observe the 'Safety information' in Section 1.

There are a number of criteria which must be satisfied to ensure that the swivel connector trap will operate correctly and ensure effective condensate removal. Referring to the Installation and Maintenance Instructions, product markings and Technical Information Sheet, check that the product is suitable for the intended installation:

- 3.1** Check materials and maximum pressure / temperature values. If the maximum operating limit of the product is lower than that of the system in which it is being fitted, ensure that a safety device is included in the system to prevent overpressurisation.
- 3.2** The correct steam trap and end connection must be selected to meet the system design conditions.
- 3.3** Steam trap connector bolts are supplied with the selected steam trap.
- 3.4** The joint between the PC10HP and trap is sealed with high integrity kammprofile gaskets. During installation the gasket faces must be protected from damage caused by weld splatter, knocks, etc.. to the trap gasket face. Hence care must be taken when installing the PC10HP into the pipework. It is recommended that the trap is installed immediately the PC10HP is in the pipework. Alternatively, the trap can be joined to the PC10HP prior to installation.
- 3.5** Determine the correct installation situation and direction of fluid flow. The PC10HP must be installed with flow in the direction of the arrow. Flow can be horizontal (either direction), vertical or inclined. The flow direction is clearly marked on the trap body or pipeline connector.
Caution: The connection face for the swivel connector steam trap of choice must always be in the vertical plane unless stated on the product specific steam trap Installation and Maintenance Instructions provided with the product.
- 3.6** Remove protection covers from all connections, where appropriate, before installation on steam or other high temperature applications.
- 3.7** Suitable isolation valves must be installed to allow for safe maintenance and trap replacement.
Where the trap discharges into a closed return system a non-return valve should be fitted downstream to prevent back flow.
- 3.8** Always open isolation valves slowly until normal operating conditions are achieved – this will avoid system shocks. Check for leaks and correct operation.
- 3.9** Always ensure the correct tools, safety procedures and protective equipment are used at all times.
- 3.11** When a socket weld version is being installed the welding should be carried out to an approved procedure of a recognised standard.

Notes:

1. If the trap is to discharge to atmosphere, ensure that it is to a safe place. The discharging fluid may be at a temperature of 100°C (212°F).
2. After installation it is recommended that the PC10HP pipeline connector is insulated to minimise radiated heat losses and to protect personnel from burns risk. **Please note** that there are some trap types that should not be insulated.

4. Commissioning

After installation and maintenance ensure that the system is fully functional. Carry out tests on any alarms or protective devices.

5. Spare parts and Maintenance

Please note that there are no spare parts for the PC10HP pipeline connector.

If spare parts are required for the steam trap that is connected to the PC10HP we recommend that you use the product specific Installation and Maintenance Instructions for that particular product.

