

MST21**Stainless Steel****Balanced Pressure Thermostatic Steam Trap**Installation and Maintenance Instructions

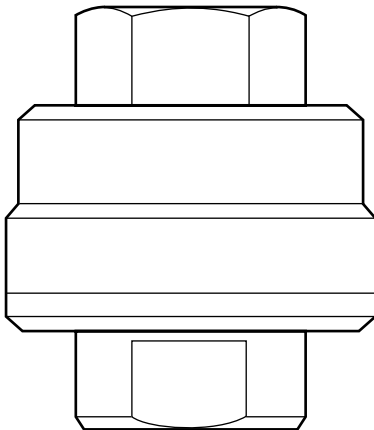

1. Safety information
2. General product information
3. Installation
4. Commissioning
5. Operation
6. Maintenance
7. Spare parts

1. Safety information

Safe operation of this product can only be guaranteed if it is properly installed, commissioned, used and maintained by qualified personnel (see Section 1.11) in compliance with the operating instructions. General installation and safety instructions for pipeline and plant construction, as well as the proper use of tools and safety equipment must also be complied with.

1.1 Intended use

Referring to the Installation and Maintenance Instructions, name-plate and Technical Information Sheet, check that the product is suitable for the intended use/application.

- i) The products' use on other fluids may be possible but, if this is contemplated, Spirax Sarco should be contacted to confirm the suitability of the product for the application being considered.
- ii) Check material suitability, pressure and temperature and their maximum and minimum values. If the maximum operating limits of the product are lower than those of the system in which it is being fitted, or if malfunction of the product could result in a dangerous overpressure or overtemperature occurrence, ensure a safety device is included in the system to prevent such over-limit situations.
- iii) Determine the correct installation situation and direction of fluid flow.
- iv) Spirax Sarco products are not intended to withstand external stresses that may be induced by any system to which they are fitted. It is the responsibility of the installer to consider these stresses and take adequate precautions to minimise them.
- v) Remove protection covers from all connections before installation.

1.2 Access

Ensure safe access and if necessary a safe working platform (suitably guarded) before attempting to work on the product. Arrange suitable lifting gear if required.

1.3 Lighting

Ensure adequate lighting, particularly where detailed or intricate work is required.

1.4 Hazardous liquids or gases in the pipeline

Consider what is in the pipeline or what may have been in the pipeline at some previous time. Consider: flammable materials, substances hazardous to health, extremes of temperature.

1.5 Hazardous environment around the product

Consider: explosion risk areas, lack of oxygen (e.g. tanks, pits), dangerous gases, extremes of temperature, hot surfaces, fire hazard (e.g. during welding), excessive noise, moving machinery.

1.6 The system

Consider the effect on the complete system of the work proposed. Will any proposed action (e.g. closing isolation valves, electrical isolation) put any other part of the system or any personnel at risk?

Dangers might include isolation of vents or protective devices or the rendering ineffective of controls or alarms. Ensure isolation valves are turned on and off in a gradual way to avoid system shocks.

1.7 Pressure systems

Ensure that any pressure is isolated and safely vented to atmospheric pressure. Consider double isolation (double block and bleed) and the locking or labelling of closed valves. Do not assume that the system has depressurised even when the pressure gauge indicates zero.

1.8 Temperature

Allow time for temperature to normalise after isolation to avoid danger of burns.

1.9 Tools and consumables

Before starting work ensure that you have suitable tools and/or consumables available. Use only genuine Spirax Sarco replacement parts.

1.10 Protective clothing

Consider whether you and/or others in the vicinity require any protective clothing to protect against the hazards of, for example, chemicals, high/low temperature, radiation, noise, falling objects, and dangers to eyes and face.

1.11 Permits to work

All work must be carried out or be supervised by a suitably competent person. Installation and operating personnel should be trained in the correct use of the product according to the Installation and Maintenance Instructions.

Where a formal 'permit to work' system is in force it must be complied with. Where there is no such system, it is recommended that a responsible person should know what work is going on and, where necessary, arrange to have an assistant whose primary responsibility is safety.

Post 'warning notices' if necessary.

1.12 Handling

Manual handling of large and/or heavy products may present a risk of injury. Lifting, pushing, pulling, carrying or supporting a load by bodily force can cause injury particularly to the back. You are advised to assess the risks taking into account the task, the individual, the load and the working environment and use the appropriate handling method depending on the circumstances of the work being done.

1.13 Residual hazards

In normal use the external surface of the product may be very hot. If used at the maximum permitted operating conditions the surface temperature of some products may reach temperatures in excess of 270°C (518°F).

Many products are not self-draining. Take due care when dismantling or removing the product from an installation (refer to 'Maintenance instructions').

1.14 Freezing

Provision must be made to protect products which are not self-draining against frost damage in environments where they may be exposed to temperatures below freezing point.

1.15 Safety information - Product specific

The cover gasket contains a thin stainless steel support ring which may cause physical injury if not handled and disposed of carefully.

1.16 Disposal

Unless otherwise stated in the Installation and Maintenance Instructions, this product is recyclable and no ecological hazard is anticipated with its disposal providing due care is taken.

1.17 Returning products

Customers and stockists are reminded that under EC Health, Safety and Environment Law, when returning products to Spirax Sarco they must provide information on any hazards and the precautions to be taken due to contamination residues or mechanical damage which may present a health, safety or environmental risk. This information must be provided in writing including Health and Safety data sheets relating to any substances identified as hazardous or potentially hazardous.

2. General product information

2.1 Description

The MST21 is a maintainable balanced pressure thermostatic steam trap designed for relatively small condensate loads usually associated with instrument tracing applications. It is manufactured in stainless steel and is corrosion resistant and easily maintainable.

Available types

MST21 Standard capacity for tracing loads (standard unit)

MST21H High capacity for special applications

Capsule fill and operation

Standard capsules are marked with the letters 'STD' for operation at approximately 10°C (18°F) below steam saturation temperature.

Optionally the capsule can be supplied for sub-cooled 'SUB' operation at approximately 22°C (39.6°F) below steam saturation temperature or a 'NTS' fill capsule for operation at approximately 4°C (7.2°F) below steam saturation temperature.

Certification

This product is available with a manufacturers' Typical Test Report. **Note:** All certification/inspection requirements must be stated at the time of order placement.

Note:

For additional information see the following Technical information Sheet: TI-IBR16-10-IN.

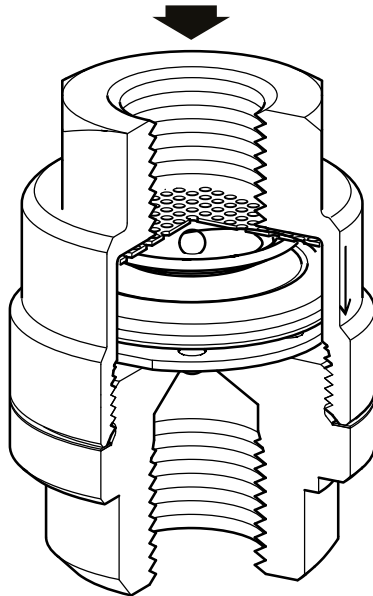

Fig. 1 MST21

2.2 Sizes and pipe connections

MST21 1/4", and 1/2" screwed BSP, EN ISO 228-1, or NPT.

MST21H 3/4" screwed BSP, EN ISO 228-1, or NPT.

2.3 Pressure/temperature limits (ISO 6552)

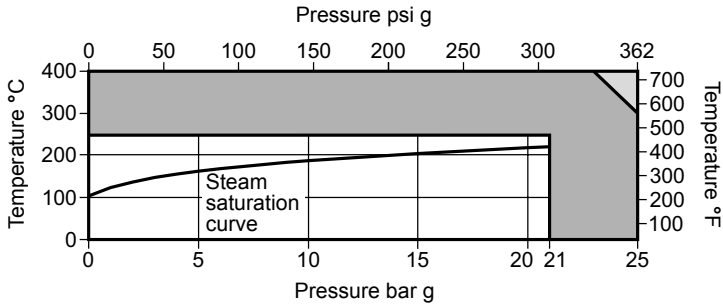

 The product **must not** be used in this region.

 The product **should not** be used in this region as damage to internals may occur.

Body design conditions			PN25
PMA	Maximum allowable pressure	25 bar g @ 300°C	(363 psi g @ 572°F)
TMA	Maximum allowable temperature	400°C @ 23 bar g	(752°F @ 333 psi g)
Minimum allowable temperature		0°C	(32°F)
PMO	Maximum operating pressure	21 bar g @ 235°C	(305 psi g @ 455°F)
TMO	Maximum operating temperature	235°C @ 21 bar g	(455°F @ 305 psi g)
Minimum operating temperature		0°C	(32°F)
Designed for a maximum cold hydraulic test pressure of:		38 bar g	(551 psi g)

3. Installation

Note: Before actioning any installation observe the 'Safety information' in Section 1.

Referring to the Installation and Maintenance Instructions, name-plate and Technical Information Sheet, check that the product is suitable for the intended installation:

- 3.1** Check materials, pressure and temperature and their maximum values. If the maximum operating limit of the product is lower than that of the system in which it is being fitted, ensure that a safety device is included in the system to prevent overpressurisation.
- 3.2** Determine the correct installation situation and the direction of fluid flow.
- 3.3** Remove protective covers from all connections and the protective film from all name-plates, where appropriate, before installation on steam or other high temperature applications.
- 3.4** The trap is designed for installation with the capsule in a vertical line with the inlet at the top and the outlet at the bottom. This will ensure that it is self-draining. If fitted in a horizontal line, the trap should be preceded by a short drop leg.
- 3.5** When the trap is discharging to atmosphere, it is strongly recommended to install a diffuser on the outlet side of the trap. This reduces any problem of noise and erosion by cushioning high velocity discharge. See TI-IBR16-10-IN for further information.
- 3.6** Suitable isolation valves must be installed to allow for safe maintenance and trap replacement.
- 3.7** Open isolation valves slowly until normal operating conditions are achieved.
- 3.8** Check for leaks and correct operation.

Note: If the trap is to discharge to atmosphere ensure it is to a safe place, the discharging fluid may be at a temperature of 100°C (212°F).

4. Commissioning

After installation or maintenance ensure that the system is fully functioning. Carry out tests on any alarms or protective devices.

5. Operation

The operating element is a capsule containing a small quantity of a special liquid with a boiling point below that of water. In the cold conditions that exist at start-up, the capsule is relaxed. The valve is off its seat and is wide open, allowing unrestricted removal of air. This is a feature of all balanced pressure traps and explains why they are well suited to air venting.

As condensate passes through the balanced pressure steam trap, heat is transferred to the liquid in the capsule. The fill liquid boils before steam reaches the trap. The vapour pressure within the capsule causes it to expand and the trap shuts. Heat loss from the trap then cools the water surrounding the capsule, the fill condenses and the capsule contracts, opening the valve and releasing condensate until steam temperature approaches again at which the cycle is repeated.

6. Maintenance

Note: Before actioning any maintenance programme observe the 'Safety information' in Section 1.

6.1 General information

Before undertaking any maintenance on the trap it must be isolated from both the supply line and return line and any pressure allowed to safely normalise to atmosphere. The trap should then be allowed to cool. When reassembling, ensure that all joint faces are clean. Maintenance can be undertaken, once the safety procedures have been observed. It is recommended that new gaskets and spares are used whenever maintenance is undertaken. Ensure that the correct tools and necessary protective equipment are used at all times. When maintenance is complete open isolation valves slowly and check for leaks.

6.2 How to replace the internals (reference Figure 2)

- Remove the cap (2) using a spanner.
- Lift out the screen (6), spring (4), capsule (3), and spacer plate (5).
- Replace with new internals in the correct order. Make sure the conical spring (4) is positioned with the narrow end in contact with the capsule.
- Fit a new gasket (7).
- Refit the cap (2) using a little anti-seize compound on the threads and tighten to the recommended torque (see Table 1).

7. Spare parts

The spare parts available are shown in solid outline. Parts drawn in grey lines are not supplied as spares.

Available spares

Internals set for MST21	3, 4, 5, 6, 7
-------------------------	----------------------



How to order spares

Always order spares by using the description given in the column headed 'Available spares' and state the size and type of trap.

Note: When placing an order always state capsule fill (see Section 2.1).

Example: 1 - Internals set for a ¼" Spirax Sarco MST21 balanced pressure thermostatic steam trap having an 'STD' fill capsule for operation at 10°C (18°F) below steam saturation temperature.

Table 1
Recommended tightening torques

Item No.	Size	 or 	mm	N m (lbf ft)
1 and 2	¼"		22 A/F	100 - 110 (73.5 - 80.9)
	½"		32 A/F	100 - 110 (73.5 - 80.9)
	¾"		36 A/F	100 - 110 (73.5 - 80.9)

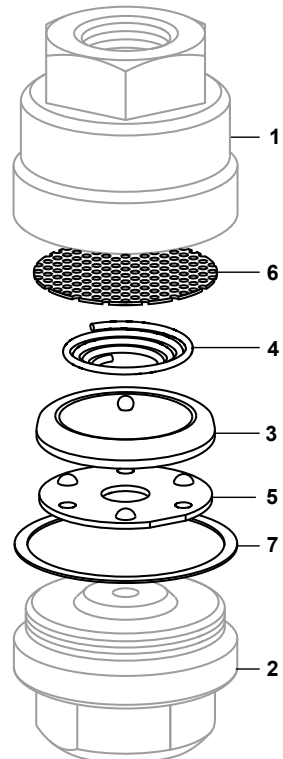

Fig. 2