

MFP14

Automatic Pumps

Installation and Maintenance Instructions

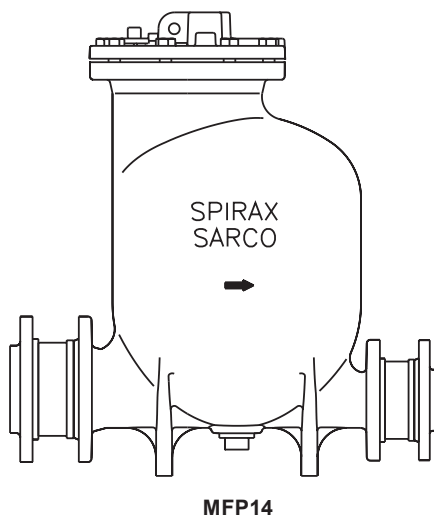

1. Safety information
2. General product information
3. Installation
4. Commissioning
5. Operation
6. Maintenance
7. Spare parts
8. Fault finding

1. General safety information

Safe operation of these products can only be guaranteed if they are properly installed, commissioned, used and maintained by qualified personnel (see Section 1.11) in compliance with the operating instructions. General installation and safety instructions for pipeline and plant construction, as well as the proper use of tools and safety equipment must also be complied with.

1.1 Intended use

Referring to the Installation and Maintenance Instructions, name-plate and Technical Information Sheet, check that the product is suitable for the intended use/application.

- i) The products have been specifically designed for use on steam, air and water/condensate. The products' use on other fluids may be possible but, if this is contemplated, Spirax Sarco should be contacted to confirm the suitability of the product for the application being considered.
- ii) Check material suitability, pressure and temperature and their maximum and minimum values. If the maximum operating limits of the product are lower than those of the system in which it is being fitted, or if malfunction of the product could result in a dangerous overpressure or overtemperature occurrence, ensure a safety device is included in the system to prevent such over-limit situations.
- iii) Determine the correct installation situation and direction of fluid flow.
- iv) Spirax Sarco products are not intended to withstand external stresses that may be induced by any system to which they are fitted. It is the responsibility of the installer to consider these stresses and take adequate precautions to minimise them.
- v) Remove protection covers from all connections and protective film from all name-plates, where appropriate, before installation on steam or other high temperature applications.

1.2 Access

Ensure safe access and if necessary a safe working platform (suitably guarded) before attempting to work on the product. Arrange suitable lifting gear if required.

1.3 Lighting

Ensure adequate lighting, particularly where detailed or intricate work is required.

1.4 Hazardous liquids or gases in the pipeline

Consider what is in the pipeline or what may have been in the pipeline at some previous time. Consider: flammable materials, substances hazardous to health, extremes of temperature.

1.5 Hazardous environment around the product

Consider: explosion risk areas, lack of oxygen (e.g. tanks, pits), dangerous gases, extremes of temperature, hot surfaces, fire hazard (e.g. during welding), excessive noise, moving machinery.

1.6 The system

Consider the effect on the complete system of the work proposed. Will any proposed action (e.g. closing isolation valves, electrical isolation) put any other part of the system or any personnel at risk?

Dangers might include isolation of vents or protective devices or the rendering ineffective of controls or alarms. Ensure isolation valves are turned on and off in a gradual way to avoid system shocks.

1.7 Pressure systems

Ensure that any pressure is isolated and safely vented to atmospheric pressure. Consider double isolation (double block and bleed) and the locking or labelling of closed valves. Do not assume that the system has depressurised even when the pressure gauge indicates zero.

1.8 Temperature

Allow time for temperature to normalise after isolation to avoid danger of burns.

1.9 Tools and consumables

Before starting work ensure that you have suitable tools and/or consumables available. Use only genuine Spirax Sarco replacement parts.

1.10 Protective clothing

Consider whether you and/or others in the vicinity require any protective clothing to protect against the hazards of, for example, chemicals, high/low temperature, radiation, noise, falling objects, and dangers to eyes and face.

1.11 Permits to work

All work must be carried out or be supervised by a suitably competent person. Installation and operating personnel should be trained in the correct use of the product according to the Installation and Maintenance Instructions.

Where a formal 'permit to work' system is in force it must be complied with. Where there is no such system, it is recommended that a responsible person should know what work is going on and, where necessary, arrange to have an assistant whose primary responsibility is safety.

Post 'warning notices' if necessary.

1.12 Handling

Manual handling of large and/or heavy products may present a risk of injury. Lifting, pushing, pulling, carrying or supporting a load by bodily force can cause injury particularly to the back. You are advised to assess the risks taking into account the task, the individual, the load and the working environment and use the appropriate handling method depending on the circumstances of the work being done.

1.13 Residual hazards

In normal use the external surface of the product may be very hot. If used at the maximum permitted operating conditions the surface temperature of these products may reach temperatures of 200°C (392°F).

These products are not self-draining. Take due care when dismantling or removing the product from an installation (refer to 'Maintenance instructions').

1.14 Freezing

Provision must be made to protect products which are not self-draining against frost damage in environments where they may be exposed to temperatures below freezing point.

1.15 Disposal

Unless otherwise stated in the Installation and Maintenance Instructions, this product is recyclable and no ecological hazard is anticipated with its disposal providing due care is taken.

1.16 Returning products

Customers and stockists are reminded that under EC Health, Safety and Environment Law, when returning products to Spirax Sarco they must provide information on any hazards and the precautions to be taken due to contamination residues or mechanical damage which may present a health, safety or environmental risk. This information must be provided in writing including Health and Safety data sheets relating to any substances identified as hazardous or potentially hazardous.

2. General product information

2.1 General description

The Spirax Sarco MFP series of automatic pumps are simply displacement receivers operated by steam or compressed air. They are generally used to lift liquids such as condensate to a higher level. Subject to the conditions being suitable, the pump can also be used to directly drain closed vessels under vacuum or pressure. In conjunction with a float steam trap, the pump is used to effectively drain temperature controlled heat exchangers under all operating conditions.

The Spirax Sarco MFP automatic pump range is available with a SG iron body and cover

Certification

This product is available with certification to EN 10204 3.1.

Note: All certification/inspection requirements must be stated at the time of order placement.

Note: For further information see Technical Information Sheet TI-IBR16-28IN.

2.2 Sizes and pipe connections

1", 1½", 2" and 3" x 2" screwed BSP and NPT.

DN25, DN40, DN50 and DN80 x DN50; flanged, ASME B16.42 Class 150.

2.3 Pressure / temperature limits (ADM/ASME Pressure vessel codes Version 5.0)

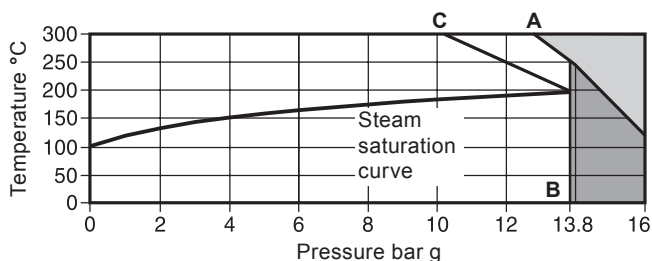

 The product **must not** be used in this region.

 For use in this region contact Spirax Sarco - As standard this product should not be used in this region or beyond its operating range.

A - B Flanged PN16

C - B Flanged ANSI 150

| | |
|--|--------------------|
| Body design conditions | PN16 |
| Maximum motive inlet pressure (steam air or gas) | 13.8 bar g |
| PMA Maximum allowable pressure | 16 bar g @ 120°C |
| TMA Maximum allowable temperature | 300°C @ 12.8 bar g |
| Minimum allowable temperature. For lower temperatures consult Spirax Sarco | 0°C |
| PMO Maximum operating pressure for saturated steam service | 13.8 bar g @ 198°C |
| TMO Maximum operating temperature for saturated steam service | 198°C @ 13.8 bar g |
| Minimum operating temperature. For lower temperatures consult Spirax Sarco | 0°C |

Total lift or backpressure (static head plus pressure in the return system) which must be below the motive fluid inlet pressure to allow capacity to be achieved:-

Height (H) in metres x 0.0981 plus pressure (bar g) in return line, plus downstream piping friction pressure drop in bar calculated at a flowrate of the lesser of six times the actual condensate rate or 30 000 litres/h.

Recommended filling head above the pump 0.3 m

Minimum filling head required 0.15 m (reduced capacity)

Standard pump operates with liquids of specific gravity: 1 down to 0.8

| | DN80 x 50 | DN50 | DN40 and DN25 |
|----------------------------|--------------------------------|--------------------------------|--------------------------------|
| Pump discharge per cycle | 19.3 litres | 12.8 litres | 7 litres |
| Steam consumption | 20 kg/h maximum | 20 kg/h maximum | 16 kg/h maximum |
| Air consumption (Free air) | 5.6 dm ³ /s maximum | 5.6 dm ³ /s maximum | 4.4 dm ³ /s maximum |

Materials

| No. | Part | Material | |
|------|---------------------------|-----------------|----------------------------------|
| 1 | Cover | SG iron | (EN JS 1025) EN-GJS-400-18-LT |
| 2 | Cover gasket | Synthetic fibre | |
| 3 | Cover screws | Stainless steel | ISO 3506 Gr. A2-70 |
| 4 | Body | SG iron | (EN JS 1025) EN-GJS-400-18-LT |
| 5 | Pillar | Stainless steel | BS 970, 431 S29 |
| 6 | Connector rod | Stainless steel | BS 1449, 304 S11 |
| 7 | Float and lever | Stainless steel | AISI 304 |
| 8 | Eyebolt (integral) | SG iron | (EN JS 1025) EN-GJS-400-18-LT |
| 9 | Mechanism lever | Stainless steel | BS 3146 pt.2 ANC 2 |
| 10 | Spring | Inconel 718 | ASTM 5962/ASTM B367 |
| 11 | Pressure plug | Steel | DIN 267 Part III Class 5.8 |
| 12 | Check valves | Stainless steel | |
| 13 | Screwed boss flanges | Steel | |
| 14 | Mechanism bracket | Stainless steel | BS 3146 pt. 2 ANC 4B |
| 15 | Bracket screws | Stainless steel | BS 6105 Gr. A2-70 |
| 16 | Inlet valve seat | Stainless steel | BS 970, 431 S29 |
| 17 | Inlet valve stem | Stainless steel | ASTM A276 440B |
| 18 | Inlet valve seat gasket | Stainless steel | BS 1449 409 S19 |
| 19 | Exhaust valve seat | Stainless steel | BS 970 431 S29 |
| 20 | Exhaust valve | Stainless steel | BS 3146 pt. 2 ANC 2 |
| 21 | Exhaust valve seat gasket | Stainless steel | BS 1449 409 S19 |
| 22 | EPM actuator | ALNICO | |
| 23 | 'O' ring seal | EPDM | |
| * 24 | Shaft | Stainless steel | BS 970 431 S29 |
| * 25 | Socket set screw | Stainless steel | BS 6105 Grade A2 |
| * 26 | Socket set screw | Stainless steel | BS 970 431 S29 |
| * 27 | Locking nut | Stainless steel | Grade A2 |
| 28 | Spring anchor | Stainless steel | BS 970 431 S29 |

* **Note:** For item **24, 25, 26** and **27** see Figure 8, page 18

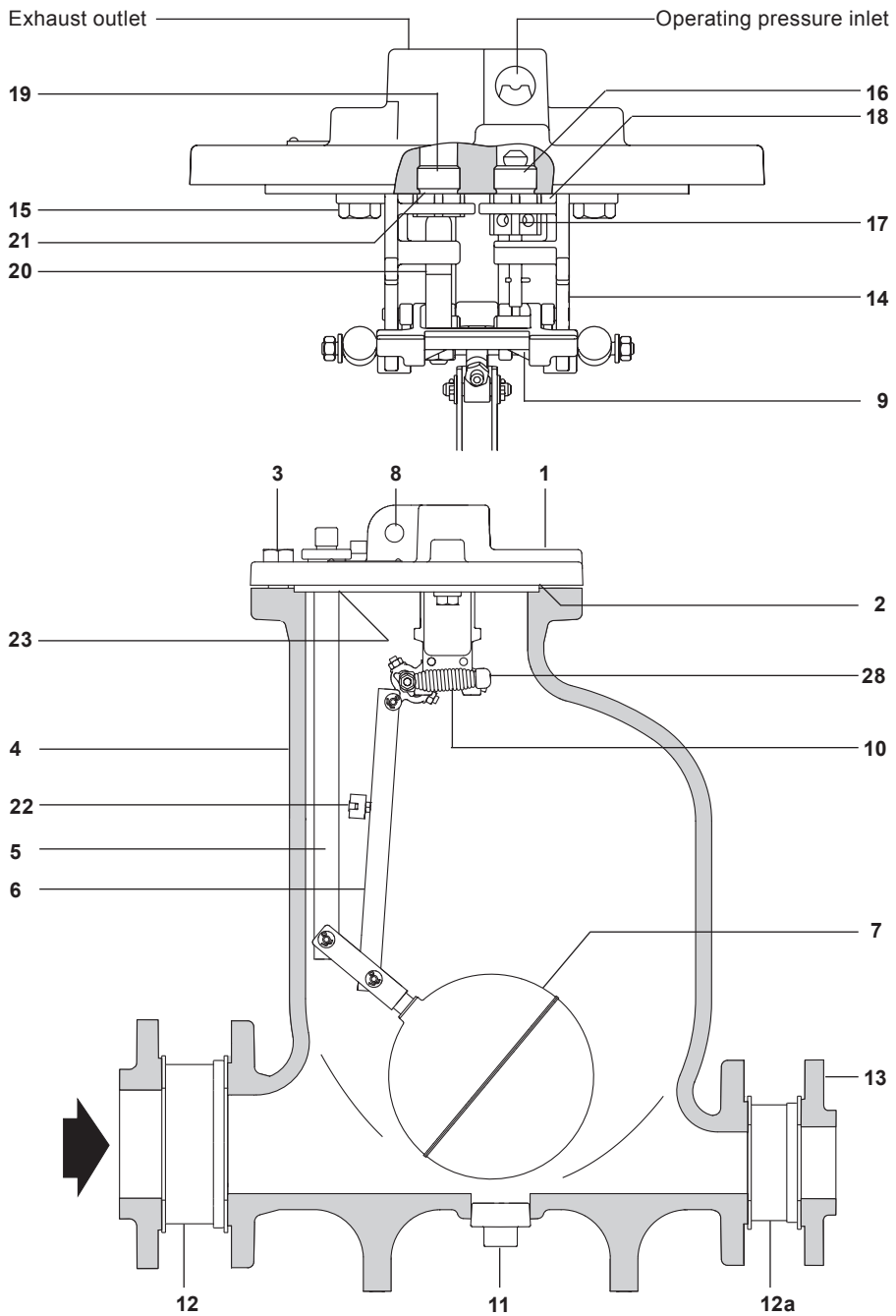

Fig. 1 DN80 x DN50 MFP14 shown

2.6 Dimensions/weights (approximate)

Metric (mm/kg)

| Size | A | | B | C | *D | E | F | G | H | J | K | L | Pump | |
|-------------|------|------|-----|-----|-----|-----|-----|-----|----|----|-----|-------|-----------|------------------------------------|
| | PN16 | ANSI | | | | | | | | | | | Pump only | Including check valves and flanges |
| DN25 | 350 | 375 | 305 | 507 | - | 68 | 68 | 480 | 13 | 18 | 165 | Ø 280 | 51 | 58 |
| DN40 | 370 | 400 | 305 | 527 | - | 81 | 81 | 480 | 13 | 18 | 165 | Ø 280 | 54 | 63 |
| DN50 | 505 | 535 | 420 | 637 | - | 104 | 104 | 580 | 33 | 18 | 245 | Ø 321 | 72 | 82 |
| DN80 x DN50 | 515 | 555 | 420 | 637 | 430 | 119 | 104 | 580 | 33 | 18 | 245 | 342 | 88 | 98 |

Imperial (ins/lbs)

| Size | A | | B | C | *D | E | F | G | H | J | K | L | Pump | |
|---------|------|------|------|------|------|-----|-----|------|-----|-----|-----|--------|-----------|------------------------------------|
| | PN16 | ANSI | | | | | | | | | | | Pump only | Including check valves and flanges |
| 1" | 13.8 | 14.8 | 12.0 | 19.9 | - | 2.7 | 2.7 | 18.9 | 0.5 | 0.7 | 6.5 | Ø 11.0 | 112.4 | 127.8 |
| 1½" | 14.6 | 15.7 | 12.0 | 20.7 | - | 3.2 | 3.2 | 18.9 | 0.5 | 0.7 | 6.5 | Ø11.0 | 119.0 | 138.9 |
| 2" | 19.9 | 21.1 | 16.5 | 25 | - | 4.1 | 4.1 | 22.8 | 1.3 | 0.7 | 9.6 | Ø12.6 | 158.7 | 180.8 |
| 3" x 2" | 20.3 | 21.9 | 16.5 | 25 | 16.9 | 4.7 | 4.1 | 22.8 | 1.3 | 0.7 | 9.6 | 13.6 | 194 | 216 |

* **Please note:** Dimension **D** only applies to the DN80 x DN50 pump which has an oval body. The DN25, DN40 and DN50 are round bodied therefore dimension **L** is sufficient.

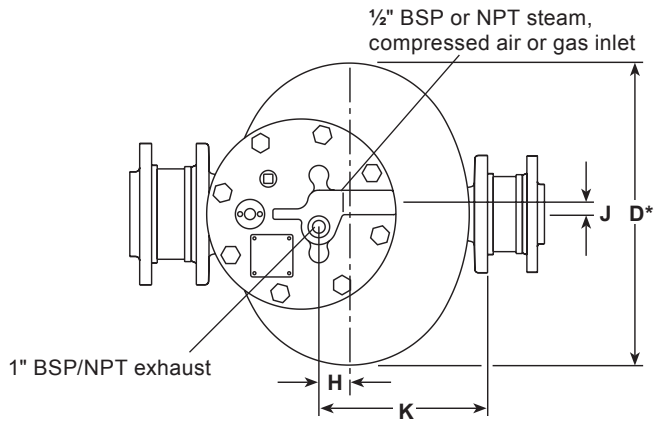

* **Please note:** Dimension **D** only applies to the DN80 x DN50 pump which has an oval body. The DN25, DN40 and DN50 are round bodied therefore dimension **L** is sufficient.

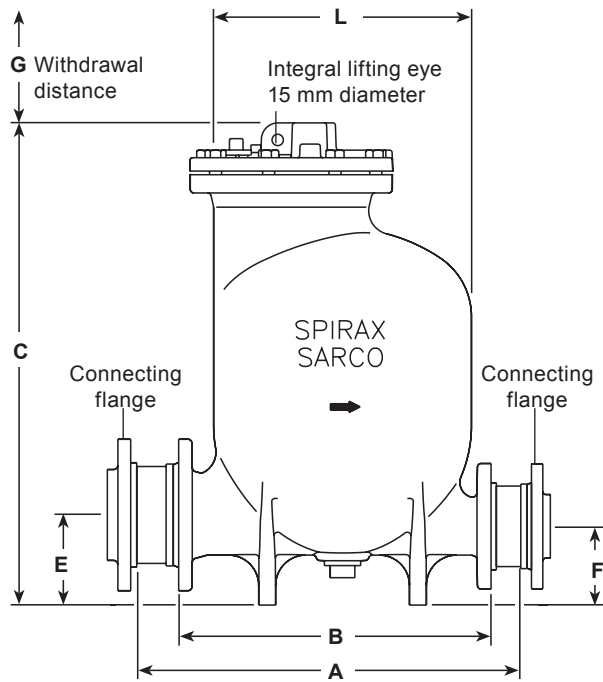

Fig. 2 DN80 x DN50 MFP14 shown

3. Installation

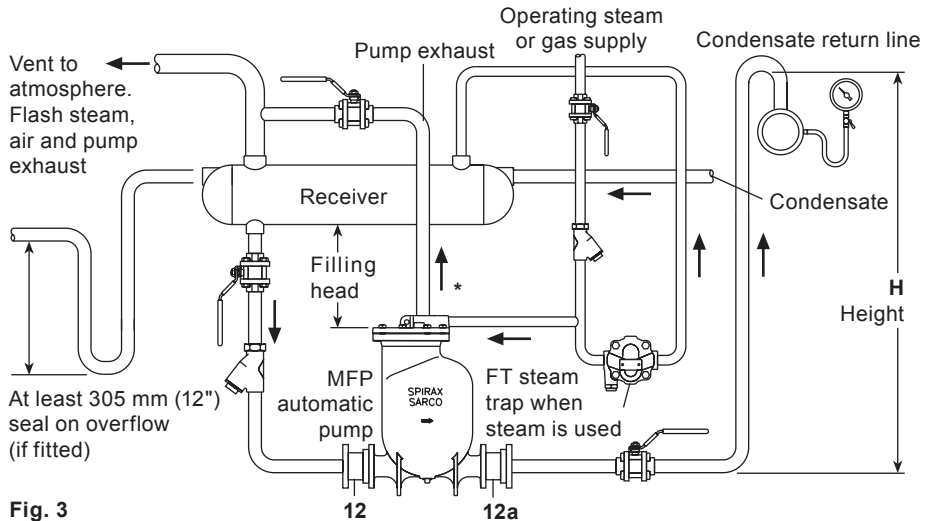

Fig. 3

3.1 Installation - vented systems

Caution. Before installation or any maintenance is performed, ensure that all steam, air or gas lines are isolated to prevent personnel injury.

Ensure any residual internal pressure in the pump or connecting lines is carefully relieved. Also ensure any hot parts have cooled to prevent risk of injury from burns. Always wear appropriate safety clothing before carrying out any installation or maintenance work.

An integral lifting eye is fitted to the pump to assist lifting. On no account should this be used to lift anything more than the pump. Always use suitable lifting gear and ensure the pump is safely secured.

Note: If pumping a potentially explosive media, the motive supply media must be an inert gas with no oxygen present.

1. Install the pump below the equipment to be drained with the exhaust connection vertically upwards. Pump should be installed with the recommended filling head (the vertical distance between the top of the pump and the bottom of the reservoir/receiver), see Section 3.2 and Fig. 3. For other filling head variations, refer to separate capacity chart.
2. To prevent equipment flooding during the pump discharge stroke, a vented receiver or reservoir pipe should be installed in a horizontal plane ahead of the pump as shown in Fig. 3. For proper receiver/reservoir sizing, refer to Tables 1 and 2 on page 13. All inlet line fittings must be full bore.
3. Connect the check valves (12) and (12a) to the pump making sure that the flow through the valves is in the correct direction.
For best performance, horizontal piping runs immediately ahead of the inlet check valve and after the discharge check valve should be kept to a minimum. Connect the discharge to the return main or other return point.
Torque tighten inlet and outlet flange bolts to 76 - 84 N m (56 - 62 lbf ft).
4. Connect the operating medium (steam, air or gas) supply to the motive supply inlet in the cover (see Fig. 2, page 11). Supply main should have a strainer and a steam trap (steam service) installed upstream of the supply inlet. The steam trap discharge should be piped to the receiver or reservoir piping ahead of the pump.

* **Recommended maximum motive/backpressure differential is between 2-4 bar g.**

5. The pump exhaust line must be piped unreduced and unrestricted to atmosphere. The line should be vertical, if possible. If horizontal runs must be used, line should be pitched so that it is self-draining to the pump or receiver. Refer to Table 3 for the recommended vent pipe sizing, page 14.

3.2 Filling head/installation head

There is often confusion between filling head and installation head. Care must be taken when calculating them. Filling head is measured from the top of the pump cover to the bottom of the receiver, installation head is measured from the bottom of the receiver to the ground.

| | | |
|--------------------|--------------------------|---|
| Recommended | Filling head | 300 mm (12") |
| | | Minimum 150 mm (6") with reduced capacity |
| | Installation head | Maximum 1 m (39") |

Note: To achieve the rated capacity, the pump must be installed with the check valves as supplied by Spirax Sarco.

Table 1 Inlet receiver capacities

Sufficient reservoir volume is needed above the filling head level to accept the condensate reaching pump during the discharge stroke. The receiver can be a length of pipe of large diameter or a tank. If desired, receiver overflow piping can be installed as shown in Fig. 3 and piped to a suitable drain. The piping must form a U-type water seal at least 305 mm (12") deep immediately after the receiver.

| Pump size | Receiver size | |
|--------------------|----------------|-----------|
| | Metric | Imperial |
| DN25 | 0.60 m x DN200 | 24" x 8" |
| DN40 | 0.60 m x DN200 | 24" x 8" |
| DN50 | 0.65 m x DN250 | 26" x 10" |
| DN80 x DN50 | 1.10 m x DN250 | 44" x 10" |

Table 2 Inlet piping with no receiver fitted

When draining a single piece of equipment and a receiver is not supplied ahead of the pump, install with sufficient piping as given in the table below, and use the recommended filling head. This will prevent any flooding of the equipment while the pump is discharging. **Note:** The Table below illustrates the length of reservoir piping above the top of the pump when the pump is installed without a receiver.

Metric Pump sizes DN25, DN40, DN50, DN80 x DN50

| Liquid load kg/h | Inlet check valve and pipe size | | | |
|---------------------|---------------------------------|-----------|-----------|----------------|
| | DN25 m | DN40 m | DN50 m | DN80 x 50 m |
| 277 or less | 1.2 | - | - | - |
| 454 | 2.0 | 1.2 | - | - |
| 681 | 3.0 | 1.5 | 1.2 | - |
| 908 | 4.0 | 1.8 | 1.5 | - |
| 1 362 | - | 3.0 | 2.1 | - |
| 1 816 | - | 3.6 | 3.0 | - |
| 2 270 | - | - | 3.6 | 1.2 |
| 2 724 | - | - | - | 1.5 |
| 3 178 | - | - | - | 1.8 |
| 3 632 | - | - | - | 2.1 |
| 4 086 | - | - | - | 2.4 |
| 4 540 | - | - | - | 2.7 |
| 9 994 | - | - | - | 3.0 |

Imperial Pump sizes 1", 1½", 2", 3" x 2"

| Liquid load lb/h | Inlet check valve and pipe size | | | |
|---------------------|---------------------------------|-----------|----------|---------------|
| | 1" ft | 1½" ft | 2" ft | 3" x 2" ft |
| 598 or less | 3.9 | - | - | - |
| 546 | 6.6 | 3.9 | - | - |
| 1 500 | 9.8 | 4.9 | 4 | - |
| 2 000 | 13.1 | 5.9 | 5 | - |
| 3 000 | - | 9.8 | 7 | - |
| 4 000 | - | 11.8 | 10 | - |
| 5 000 | - | - | 12 | 4 |
| 6 000 | - | - | - | 5 |
| 7 000 | - | - | - | 6 |
| 8 000 | - | - | - | 7 |
| 9 000 | - | - | - | 8 |
| 10 000 | - | - | - | 9 |
| 11 000 | - | - | - | 10 |

Table 3 Receiver vent sizing

The minimum vent diameter of the receiver should be as follows:

| Pump size | | Receiver vent diameter | |
|-------------|---------|------------------------|-------|
| DN25 | 1" | 50 mm | (2") |
| DN40 | 1½" | 65 mm | (2½") |
| DN50 | 2" | 80 mm | (3") |
| DN80 x DN50 | 3" x 2" | 100 mm | (4") |

3.3 Installation - closed loop steam systems

Note: A closed-loop steam installation is one in which the exhaust line of the pump is piped back (pressure equalized) to the steam space being drained.

Caution

Before installation or any maintenance is performed, ensure that all steam, air or gas lines are isolated to prevent personnel injury.

Ensure any residual internal pressure in the pump or connecting lines is carefully relieved. Also ensure any hot parts have cooled to prevent risk of injury from burns. Always wear appropriate safety clothing before carrying out any installation or maintenance work.

An integral lifting eye is fitted to the pump to assist lifting (pump weighs 70 kg, 154 lbs). On no account should this be used to lift anything more than the pump. Always use suitable lifting gear and ensure the pump is safely secured.

Note: If pumping a potentially explosive media, the motive supply media must be an inert gas with no oxygen present.

1. Install the pump below the equipment being drained with the exhaust connection vertically upwards. The pump should be installed with the recommended filling head (vertical distance between the top of the pump and the bottom of the reservoir/receiver), see Section 3.2 and Figs. 4 and 5. For other filling head variants, refer to separate capacity chart.
2. To prevent equipment flooding during the pump discharge stroke, a vented receiver or reservoir pipe should be installed in a horizontal plane ahead of the pump as shown in Fig. 4. For proper receiver/reservoir sizing refer to Tables 1 and 2 on page 13. All inlet fittings must be full bore.
3. Connect the check valves (12) and (12a) to the pump, making sure that the flow through the valves is in the correct direction.
For best performance, horizontal piping runs immediately ahead of the inlet check valve and after the discharge check valve should be kept to a minimum. Connect the discharge to the return main or other return point.
Torque tighten inlet and outlet flange bolts to 76 - 84 N m (56 - 62 lbf ft).
4. Connect the operating medium (steam only) supply to the motive supply inlet in the cover. Supply main should have a strainer and a steam trap installed upstream of the supply inlet. Steam trap discharge should be piped to receiver or reservoir piping ahead of the pump.
Recommended maximum motive/backpressure differential is between 2-4 bar g.
5. Exhaust line should be piped, unrestricted, to the reservoir. (In some specific cases it can be connected to the inlet pipe between the control valve and the equipment or directly into the top (inlet side) of the equipment). A thermostatic air vent should be installed at the highest point of the exhaust line to vent all non-condensibles during start-up. Any horizontal runs in the exhaust line should be pitched so that the line is self-draining.
6. If, at any time, the backpressure against the pump is less than the pressure in the equipment being drained, a properly sized float and thermostatic trap must be installed between the pump and discharge check valve as shown in Fig. 5.

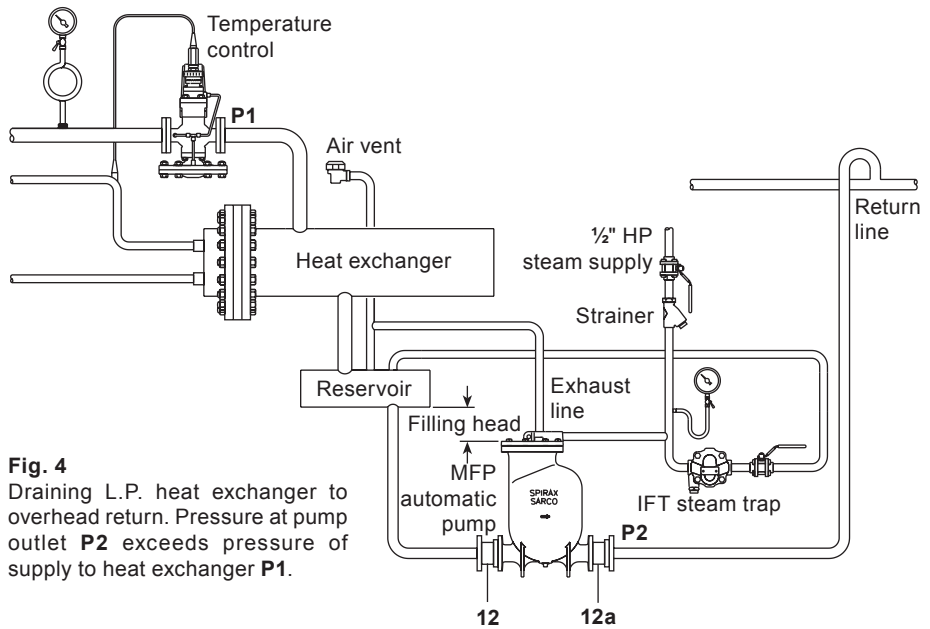

Fig. 4
Draining L.P. heat exchanger to overhead return. Pressure at pump outlet **P2** exceeds pressure of supply to heat exchanger **P1**.

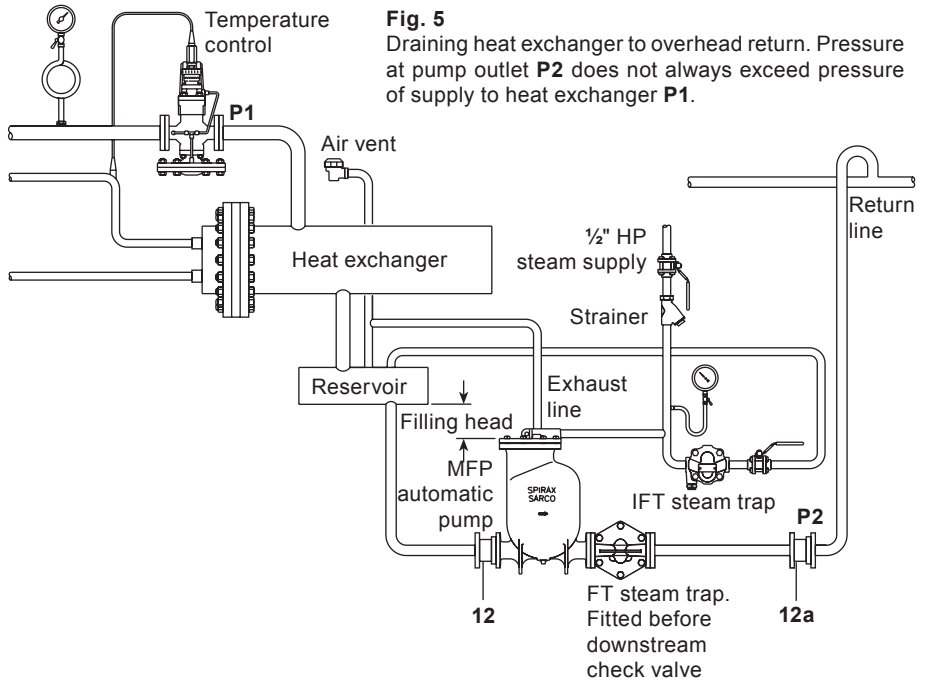

Fig. 5
Draining heat exchanger to overhead return. Pressure at pump outlet **P2** does not always exceed pressure of supply to heat exchanger **P1**.

4. Commissioning

1. Slowly open supply (steam, air or gas) to provide pressure at the MFP pump inlet valve. Check that trap is operational.
2. Open isolation valves in the condensate inlet and discharge line.
3. Open valve(s) ahead of the unit allowing condensate to enter the receiver and fill the pump body. Pump will discharge when full.
4. Observe operation for any abnormalities. MFP pump(s) should cycle periodically (minimum cycle time is 8 seconds) with an audible exhaust at the end of the pumping cycle. If any irregularities are observed, recheck installation instructions for proper arrangement - also reference Section 8 - Fault finding. Consult Spirax Sarco if necessary.
5. If overflow piping has been provided, check that a water seal has been established to prevent any steam from being emitted in normal operation. Prime piping if necessary.

5. Operation

1. Before start up the float (7) is at its lowest position with the steam valve (17) closed and exhaust valve (20) open (Fig. 6).
2. When liquid flows by gravity through inlet check valve (12) into the pump body, the float (7) will rise.
3. As the float (7) continues to rise the mechanism link (9) is engaged which increases the tension in the springs (10). When the float (7) has risen to its upper tripping position, the linkage mechanism snaps upward over centre. The energy in the springs is released as mechanism link (9) accelerates upward, simultaneously opening the motive steam inlet valve and closing the exhaust valve (Fig. 7).
4. Steam flow through the inlet valve (17) increases the pressure within the body. This closes the inlet check valve (12) and forces out the liquid through the discharge check valve (12a).
5. As the liquid level in the pump body falls the float lowers and the mechanism link (9) is engaged, which again increases the tension in the springs (10). When the float reaches the lower tripping position, the linkage mechanism snaps downward over centre. The energy in the spring is released thus accelerating the mechanism downward simultaneously opening the exhaust valve and closing the steam inlet valve.
6. When the pressure in the pump body has exhausted to the same level as the pressure in the inlet pipe, the inlet check valve opens. Liquid will again flow through the check valve to fill the body and begin the next cycle.

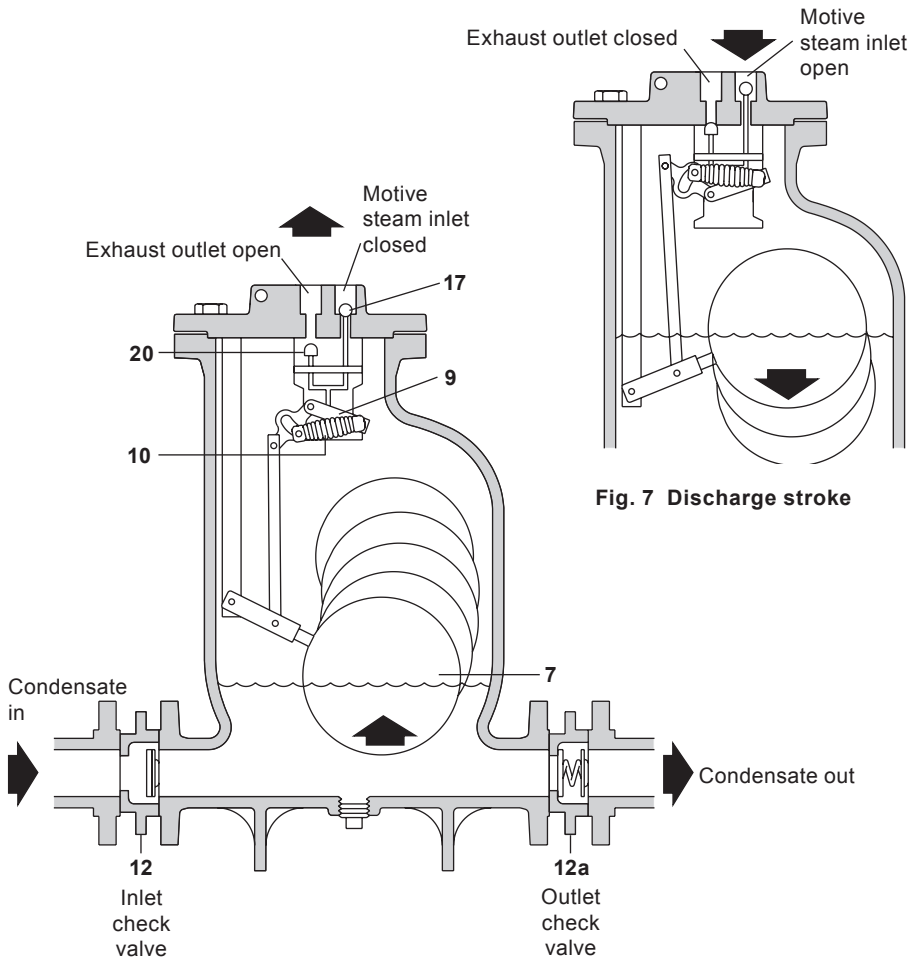

Fig. 6 Filling stroke

Fig. 7 Discharge stroke

6. Maintenance

Mechanism inspection and repair

Caution. Before installation or any maintenance is performed, ensure that all steam, air or gas lines are isolated to prevent personnel injury.

Consider what media or substance may have been or be within the pump and ascertain what possible hazards or injury may be caused by opening the pump.

Ensure any residual internal pressure in the pump or connecting lines is carefully relieved. Also ensure any hot parts have been cooled to prevent risk of injury from burns.

Always wear appropriate safety clothing before carrying out any installation or maintenance work.

An integral lifting eye is fitted to the pump to assist lifting. On no account should this be used to lift anything more than the pump. Always use suitable lifting gear and ensure the pump is safely secured.

When dismantling the pump, care should be taken to prevent personal injury from the strong snap action mechanism.

Always handle with care.

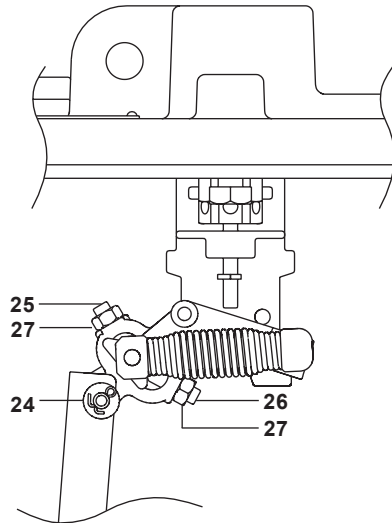

Fig. 8

1. Disconnect all connections to the cover. Remove cover bolts and lift the cover and mechanism assembly from the body, noting the cover orientation.
2. Visually inspect the mechanism to verify that it is free of dirt and scale and moves freely. **Note: The socket set screws (Fig. 8 items 25, 26) are factory set and must not be disturbed during the following maintenance procedures.**
3. Visually check springs (item 10, Fig. 9). If defective, remove nuts and washers and slide spring assemblies from shafts. Replace with new spring assemblies (see Step 5e - spring setting) and install new nuts and washers, using Loctite 620 adhesive on threads of shaft.
4. **To check inlet and exhaust valves:-**
 - a. Remove shaft (item 24, Fig. 8) from mechanism end of connector rod and rotate float and connector rod to opposite side of pillar.
 - b. Remove spring split pins/washers and nuts and slide spring assemblies from pivot shafts.
 - c. Remove locking nut from inlet valve stem. **Note:** this has been secured using loctite 620 adhesive.
 - d. Remove mechanism bracket screws and lift mechanism from cover.
 - e. To remove exhaust valve (if necessary), ease exhaust side bracket off main shaft and exhaust valve (This is achieved by lifting the levers up, away from the bracket feet, and tilting the bracket sideways and up). Remove exhaust valve from lever.
 - f. Remove seats (and inlet valve) from cover. Note their respective positions in the cover. The DN25 and DN40 valve seats can be identified by a double row of diamond grooves on the exhaust seat and a single row on the inlet seat. The DN50 and DN50 x DN80 valve seats can be distinguished as the inlet valve seat contains a series of holes around each flat, whilst the exhaust valve seat is blank.
 - g. Visually inspect seating surfaces of inlet and exhaust valves for signs of wear (inlet valve must be removed to check seat). Clean seating areas and re-install or replace if necessary.

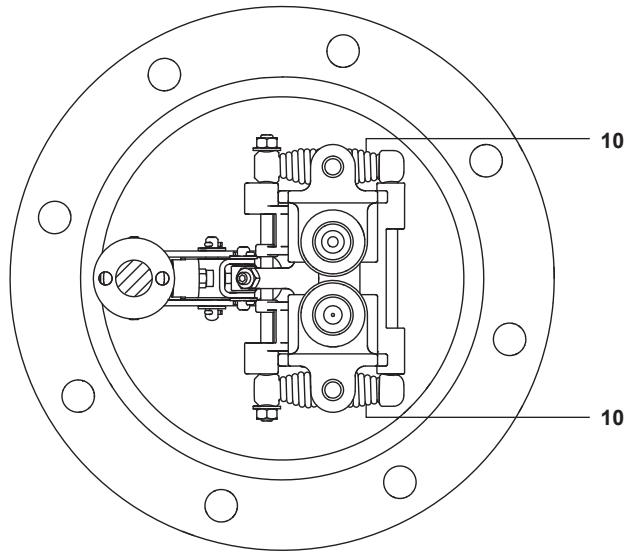

Fig. 9

5. To reassemble, reverse the above procedure noting the following:-

- a. Ensure exhaust and inlet seats (with inlet valve) are placed in correct locations (Step 4f) and tighten torque to 129 - 143 N m (95 - 105 lbf ft).
 - b. Exhaust valve assembly - Place spring into body of exhaust valve. Slide valve on to lever whilst holding spring down in bottom of bore. Fit socket set screw and lock-nut to valve.
 - c. Torque tighten mechanism retaining screws to 38 - 42 N m (28 - 31 lbf ft).
 - d. Replace split pin on inlet valve.
 - e. **Reset exhaust valves as follows** - With the valve operating lever against the stop closest to the cover (i.e. exhaust valve in the closed position) and the valve held firmly on its seat, screw in the set screw until it touches the drive pin and then unscrew it $3\frac{3}{4}$ turns for the DN80 x DN50 and DN50 pumps and $2\frac{3}{4}$ turns for the DN40 and DN25 pumps. Lock this screw in this position.
- 6. Float replacement** - Unscrew the float from the retaining bolt. It will be necessary to remove the float lever shaft to gain access to the hex socket. Reassemble the new float to the lever using a new bolt, washers and Loctite 620 adhesive on the bolt threads. If the lever shaft has been removed, fit new split pins and washers.
- 7.** When reinstalling the cover and mechanism assembly, the cover should be oriented as noted (Step 1) above. Always fit new gaskets. Torque tighten cover bolts to 121-134 N m (89 - 99 lbf ft). Follow the start-up procedure (Section 4, Commissioning) to bring the pump back into operation.

7. Spare parts

The spare parts available are detailed below. No other parts are available as spares.

Available spares

| | |
|--|---------------------------|
| Cover gasket | 2 |
| Float | 7 |
| Inlet/outlet check valve (each) | 12 |
| Cover and internal mechanism assembly (complete) | 1, 2, 7 |
| Valve set | 16, 17, 18, 19, and seats |
| Spring and shaft kit | 20, 21 |
| Mechanism kit (including inlet and exhaust valves and securing screws) | |

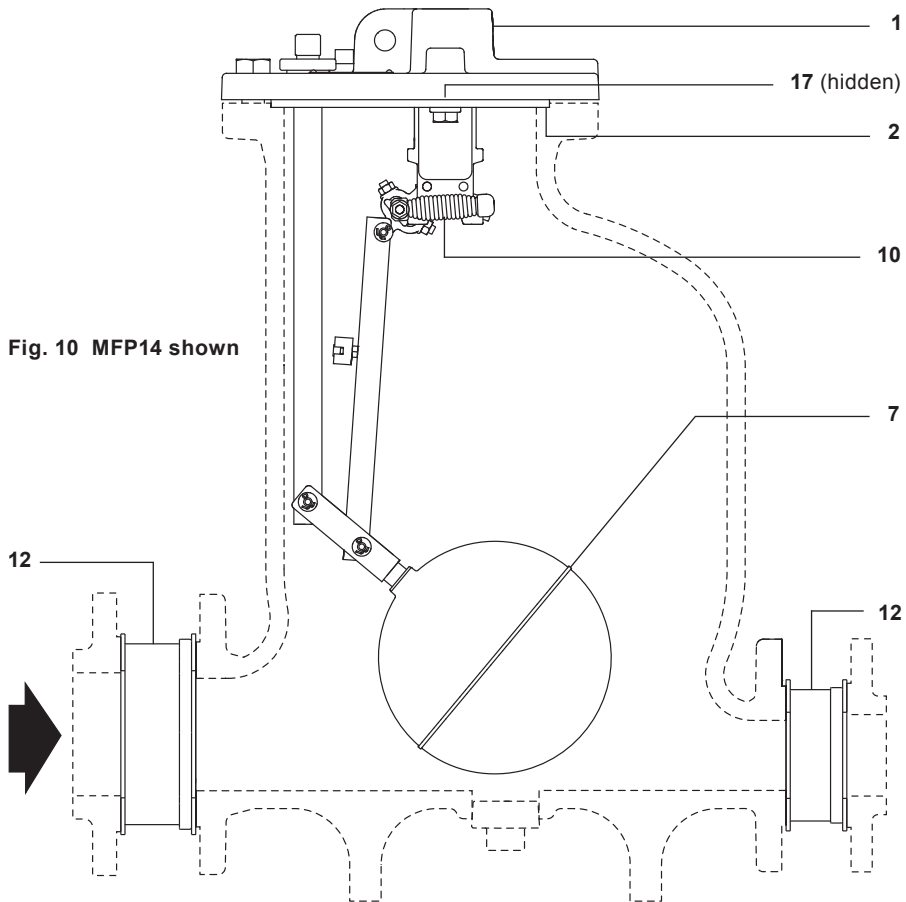
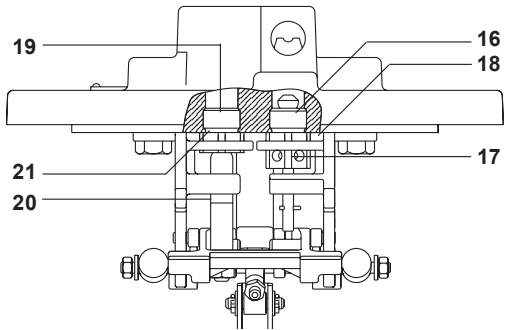

Fig. 10 MFP14 shown

8. Fault finding

If a correctly sized MFP automatic pump does not operate properly, when fitted to a new installation, an incorrect arrangement can be suspected. For existing installations where the pump operates occasionally or not at all, the cause is often a change in the system supply or backpressure conditions beyond the original design parameters. With the system conditions and problem symptoms determined, check the following in turn and correct as necessary.

Caution:

Installation and troubleshooting should be performed by qualified personnel. Before disconnecting any connections to the pump or piping system, every effort should be made to assure that internal pressure has been relieved and that the motive supply line is isolated to prevent inadvertent discharge of the pump. Consider what media or substance may have been or be within the pump and ascertain what possible hazards or injury may be caused by opening the pump. When disconnecting any connection, piping/bolts should be removed slowly so that if the line is under pressure, this fact will be apparent before completely removing the pipe or component.

Warning:

Always relieve pressure before disconnecting any joint.

| | |
|--------------------------|--|
| SYMPTOM 1 | Pump fails to operate on start-up. |
| Cause 1a | Motive supply closed. |
| Check and cure 1a | Open valves to supply motive pressure to pump. |
| Cause 1b | Condensate inlet line closed. |
| Check and cure 1b | Open all valves to allow condensate to reach pump. |
| Cause 1c | Condensate discharge line closed. |
| Check and cure 1c | Open all valves to allow free discharge from pump to destination. |
| Cause 1d | Motive pressure insufficient to overcome backpressure. |
| Check and cure 1d | Check motive pressure and static backpressure. Adjust motive pressure to 0.6 to 1 bar (8.7 to 14.5 psi) or more higher than static backpressure. It is strongly recommended that the maximum differential pressure is not more than 2-4 bar g. |
| Cause 1e | Check that the valve(s) are not installed in the wrong direction. |
| Check and cure 1e | Verify proper flow direction and correct if required. |
| Cause 1f | Restricted vent. |
| Check and cure 1f | On vented or closed systems, ensure that the vent line is unrestricted and self-draining to the pump or receiver. |

Continued overleaf

SYMPTOM 2**Supply line/equipment flooded, but pump appears to cycle normally (periodic audible exhaust observed).**

| | |
|--------------------------|---|
| Cause 2a | Pump undersized. |
| Check and cure 2a | Verify rated capacity table (TI-IBR16-28IN). Increase check valve size or install additional pump as required. |
| Cause 2b | Insufficient filling head. |
| Check and cure 2b | Verify required filling head per Section 3, page 12 - Lower pump to achieve required filling head. |
| Cause 2c | Insufficient motive pressure to achieve rated capacity. |
| Check and cure 2c | Check motive pressure setting and maximum backpressure during operation. Compare to capacity table (TI-IBR16-28IN). Increase motive pressure as required to meet load conditions. It is strongly recommended that the maximum differential pressure is not more than 2-4 bar g. |
| Cause 2d | Restriction in condensate inlet line. |
| Check and cure 2d | Verify that full bore fittings are used. Clean the strainer, if fitted. Check that all valves are fully open. |
| Cause 2e | Inlet or outlet check valve stuck open (debris). |
| Check and cure 2e | Isolate check valve and relieve line pressure. Remove disc check valve and visually inspect the disc and spring. Ensure these are free from debris clean seating surfaces to reinstall or replace if necessary. |

SYMPTOM 3**Supply line/equipment flooded, and pump has stopped cycling (audible periodic exhaust not observed).**

| | |
|--------------------------|---|
| Cause 3a | Discharge line closed or blocked. |
| Check and cure 3a | Check motive pressure and static backpressure (at pump discharge). If equal, a closed or blocked discharge line is suspected. Check all valves downstream of pump to ensure an unobstructed discharge. |
| Cause 3b | Discharge check valve stuck closed. |
| Check and cure 3b | After checking per 3(a), isolate discharge check valve and relieve line pressure. Remove the check valve and visually inspect. Clean seating surfaces and reinstall or replace, if necessary. |
| Cause 3c | Insufficient motive pressure. |
| Check and cure 3c | If motive pressure is below static backpressure, increase motive pressure setting to 0.6 to 1 bar (8.7 to 14.5 psi) or more above the static backpressure. Do not exceed rated pressure limits of equipment. It is strongly recommended that the maximum differential pressure is not more than 2-4 bar g. |

For Steps **3(d)** to **3(g)** - with exhaust/feedback line isolated from the equipment being drained (close-loop systems), break the exhaust/feedback connection at the pump cover and:-

Important safety note:

For steps **(d)** through to **(g)**. It is necessary to disconnect the exhaust/feedback line at the pump exhaust connection. To avoid injury to personnel on closed loop systems care should be exercised to ensure that the pump is isolated (motive supply, condensate inlet and discharge

and exhaust feedback line all closed) and that internal pressure is relieved prior to breaking this connection. Also, under fault conditions it is possible that hot condensate may run out of the exhaust connection when disconnected for both closed loop and vented systems. This possibility should be taken into consideration when performing these Steps to avoid scalding personnel. Always wear suitable protective safety clothing/equipment. When dismantling the pump, care should be taken to prevent personal injury from the strong snap action mechanism. **Always handle with care.**

Cause 3d **Motive inlet valve leaking/or worn.**
Check and cure 3d Slowly open the motive supply line, leaving the condensate inlet and discharge lines closed. Observe the exhaust connection for significant steam or air leakage. If leakage is observed and is not considered to be flash steam, an inlet valve problem is indicated. Isolate pump, remove cover and mechanism assembly and visually inspect. Replace inlet valve and seat assembly.

Cause 3e **Mechanism faults:-**
 1. Broken springs/shaft
 2. Ruptured float
 3. Mechanism binding
Check and cure 3e With motive line open, slowly open the condensate inlet line to the pump allowing pump to fill and observe exhaust connection. Keep personnel clear of exhaust! If condensate is emitted from the exhaust connection without the pump mechanism tripping a mechanism fault is clearly indicated.
 Isolate the pump by shutting off motive supply and condensate inlet, remove cover and mechanism assembly, and visually inspect. Examine springs/mechanism and float for obvious defects. Manually operate the mechanism and check for any source of binding or increased friction. Repair and/or replace all defective parts observed.

Cause 3f **Exhaust/feedback causing vapour lock (vented or closed loop).**
Check and cure 3f If the mechanism is heard to trip and no fluid is emitted from the exhaust connection, slowly open the discharge line from the pump and observe operation. Keep personnel clear of exhaust connection. If pump cycles normally, a fault in the exhaust/feedback line is suspected. Recheck the exhaust/feedback piping layout for compliance with the installation instructions. Exhaust/feedback line must be self-draining to prevent vapour locking the pump.
 Fit thermostatic air vent to balance line on closed loop applications. Ensuring it is higher than the possible flood level of the equipment it is draining.

Cause 3g **Inlet check valve stuck closed.**
Check and cure 3g If the mechanism does not trip and fluid does not emit it is suspected that the fault lies in the condensate inlet piping. Ensure that all valves leading to the pump have been opened. If so, this indicates that the inlet check valve is stuck closed or there is insufficient filling head. Isolate the pump and check valve and relieve line pressure:
 - Remove the check valve and visually inspect.
 - Clean seating surfaces and reinstall or replace, if necessary.
 - Reinstall exhaust/feedback connection and open line

Symptom 3 continued overleaf.

**SYMPTOM 3
CONTD. Supply line/equipment flooded, and pump has stopped cycling
(audible periodic exhaust not observed).**

Cause 3h **Inlet strainer blocked.**

Check and cure 3h Close isolation valve ahead of strainer. Remove strainer cap and screen. Clean screen or replace if damaged. Insert screen in cap and refit to strainer. Open isolation valve.

SYMPTOM 4 Clanging or banging in return main after discharges.

Cause 4a **Vacuum created at pump outlet after discharge because of acceleration/deceleration of large water slug in return main (usually results from long horizontal run with multiple rises and drops).**

Check and cure 4a Install a vacuum breaker at the top of the lift (at highest point in return line). For pressurised return systems an air eliminator may be required downstream of the vacuum breaker. Consult Spirax Sarco.

Cause 4b **Pump 'blow-by'.**

Check and cure 4b Check condensate inlet pressure and static backpressure at the pump discharge. If the inlet pressure equals or exceeds the static backpressure, a 'blow through' problem is suspected. On vented systems, check for leaking traps discharging into the condensate inlet line which would increase inlet line pressure. Replace any faulty traps. On closed loop systems, if condensate inlet pressure can exceed static backpressure under normal operation (i.e. boost in equipment operating pressure via a modulating control valve or significant decrease in static return main pressure), a pump/trap combination is required. The pump/trap combination will prevent passage of steam into the return main and allow the pump to cycle normally when condensate is present (See Fig. 5, page 15).

Cause 4c **Differential pressure too high. If the steam motive pressure vastly exceeds the required pressure to overcome the backpressure acting against the pump, the temperature of the pumped condensate will be at a greatly elevated temperature to the condensate in the return line. The flash steam caused by the higher temperature pumped condensate will collapse when it comes into contact with the cooler condensate in the return line, causing an audible banging.**

Check and cure 4c It is strongly recommended that the steam motive supply pressure does not exceed the total possible backpressure by more than 2-4 bar g. A motive supply taken from higher pressure steam lines should be reduced by a suitable pressure reducing valve.

SYMPTOM 5**Vent line discharging excessive flash steam
(vented applications only).**

Cause 5a **Faulty steam traps discharging live steam into condensate inlet line (see also 4(b), Pump 'blow-by').**

Check and cure 5a Check for leaking traps discharging into condensate return. Repair or replace faulty traps.

Cause 5b **Excessive (over 20 kg/h or 45 lb/h) flash steam being vented through pump.**

Check and cure 5b Vent receiver or reservoir piping ahead of pump.

Cause 5c **Exhaust valve stuck or worn.**

Check and cure 5c Isolate pump and remove cover and mechanism assembly. Remove exhaust valve and seat assembly. Visually inspect seating surface. Clean and reinstall or replace, if worn.
