

## Fig 37

### Flanged Strainers

Installation and Maintenance Instructions

---

---

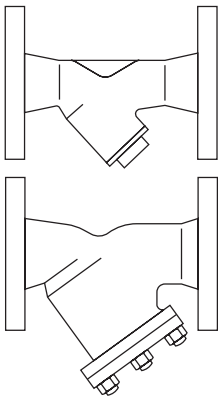

1. Safety information
2. General product information
3. Installation
4. Commissioning
5. Operation
6. Fault finding
7. Maintenance
8. Spare parts

# 1. Safety information

Safe operation of these products can only be guaranteed if they are properly installed, commissioned, used and maintained by qualified personnel (see Section 1.11) in compliance with the operating instructions. General installation and safety instructions for pipeline and plant construction, as well as the proper use of tools and safety equipment must also be complied with.

## 1.1 Intended use

Referring to the Installation and Maintenance Instructions, name-plate and Technical Information Sheet, check that the product is suitable for the intended use/application.

The products listed below comply with the requirements of the Indian Boiler Regulations, 1950.

- i) These products have been specifically designed for use on steam, air or water /condensate. The products' use on other fluids may be possible but, if this is contemplated, Spirax Sarco should be contacted to confirm the suitability of the product for the application being considered.
- ii) Check material suitability, pressure and temperature and their maximum and minimum values. If the maximum operating limits of the product are lower than those of the system in which it is being fitted, or if malfunction of the product could result in a dangerous overpressure or overtemperature occurrence, ensure a safety device is included in the system to prevent such over-limit situations.
- iii) Determine the correct installation situation and direction of fluid flow.
- iv) Spirax Sarco products are not intended to withstand external stresses that may be induced by any system to which they are fitted. It is the responsibility of the installer to consider these stresses and take adequate precautions to minimise them.
- v) Remove protection covers from all connections and protective film from all name-plates, where appropriate, before installation on steam or other high temperature applications.

## 1.2 Access

Ensure safe access and if necessary a safe working platform (suitably guarded) before attempting to work on the product. Arrange suitable lifting gear if required.

## 1.3 Lighting

Ensure adequate lighting, particularly where detailed or intricate work is required.

## 1.4 Hazardous liquids or gases in the pipeline

Consider what is in the pipeline or what may have been in the pipeline at some previous time. Consider: flammable materials, substances hazardous to health, extremes of temperature.

## **1.5 Hazardous environment around the product**

Consider: explosion risk areas, lack of oxygen (e.g. tanks, pits), dangerous gases, extremes of temperature, hot surfaces, fire hazard (e.g. during welding), excessive noise, moving machinery.

## **1.6 The system**

Consider the effect on the complete system of the work proposed. Will any proposed action (e.g. closing isolation valves, electrical isolation) put any other part of the system or any personnel at risk?

Dangers might include isolation of vents or protective devices or the rendering ineffective of controls or alarms. Ensure isolation valves are turned on and off in a gradual way to avoid system shocks.

## **1.7 Pressure systems**

Ensure that any pressure is isolated and safely vented to atmospheric pressure. Consider double isolation (double block and bleed) and the locking or labelling of closed valves. Do not assume that the system has depressurised even when the pressure gauge indicates zero.

## **1.8 Temperature**

Allow time for temperature to normalise after isolation to avoid danger of burns.

## **1.9 Tools and consumables**

Before starting work ensure that you have suitable tools and/or consumables available. Use only genuine Spirax Sarco replacement parts.

## **1.10 Protective clothing**

Consider whether you and/or others in the vicinity require any protective clothing to protect against the hazards of, for example, chemicals, high/low temperature, radiation, noise, falling objects, and dangers to eyes and face.

## **1.11 Permits to work**

All work must be carried out or be supervised by a suitably competent person. Installation and operating personnel should be trained in the correct use of the product according to the Installation and Maintenance Instructions.

Where a formal 'permit to work' system is in force it must be complied with. Where there is no such system, it is recommended that a responsible person should know what work is going on and, where necessary, arrange to have an assistant whose primary responsibility is safety.

Post 'warning notices' if necessary.

## **1.12 Handling**

Manual handling of large and/or heavy products may present a risk of injury. Lifting, pushing, pulling, carrying or supporting a load by bodily force can cause injury particularly to the back. You are advised to assess the risks taking into account the task, the individual, the load and the working environment and use the appropriate handling method depending on the circumstances of the work being done.

## **1.13 Residual hazards**

In normal use the external surface of the product may be very hot. If used at the maximum permitted operating conditions the surface temperature of some products may reach temperatures of 260 °C (500 °F).

Many products are not self-draining. Take due care when dismantling or removing the product from an installation (refer to 'Maintenance instructions').

## **1.14 Freezing**

Provision must be made to protect products which are not self-draining against frost damage in environments where they may be exposed to temperatures below freezing point.

## **1.15 Disposal**

Unless otherwise stated in the Installation and Maintenance Instructions, this product is recyclable and no ecological hazard is anticipated with its disposal providing due care is taken.

## **1.16 Returning products**

Customers and stockists are reminded that under EC Health, Safety and Environment Law, when returning products to Spirax Sarco they must provide information on any hazards and the precautions to be taken due to contamination residues or mechanical damage which may present a health, safety or environmental risk. This information must be provided in writing including Health and Safety data sheets relating to any substances identified as hazardous or potentially hazardous.

# 2. General product information

## 2.1 General description

The products detailed below are all strainers with flanged connections. They are used to protect other pipeline items from damage due to debris and dirt in the system. The standard stainless steel screen in the DN15 to DN80 sizes has 0.8 mm perforations. In the DN100 to DN200 sizes, they have 1.6 mm perforations. Optional screens are available for the Y-type strainers only, see Section 2.2.

**Note:** For additional information see the following Technical Information Sheets:

Body material	Body rating	Size	TI reference
SG iron	ASME 150	DN15 - DN200	TI-IBR17-46IN

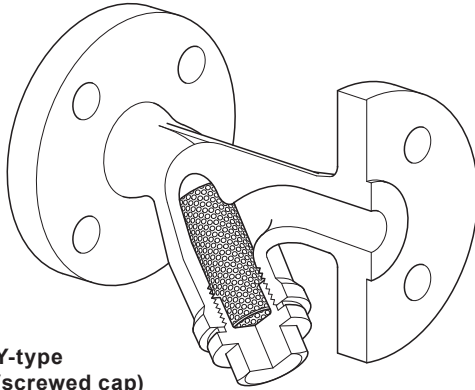

**Y-type  
(screwed cap)**

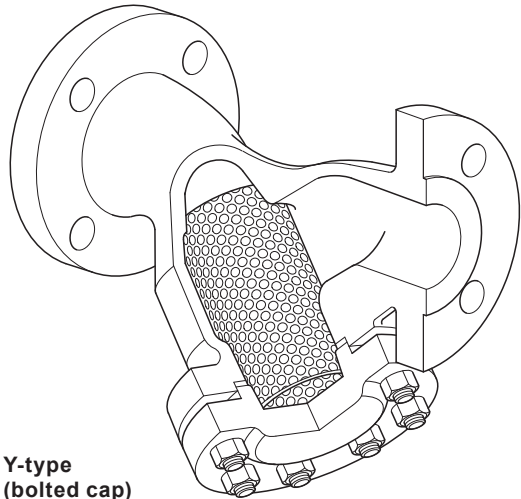

**Y-type  
(bolted cap)**

## 2.2 Optional extras

<b>Strainer screens</b>	<b>Stainless steel screen</b>	Perforations	1.6, 3 mm
		Mesh	40, 100, 200
	<b>Monel screen</b>	Perforations	0.8, 3 mm
		Mesh	100

### Blowdown or drain valve connections

The cap can be drilled and tapped to the following sizes to enable a blowdown or drain valve to be fitted.

<b>Strainer</b>	<b>Size</b>	<b>Blowdown valve</b>	<b>Drain valve</b>
<b>Fig 37</b>	<b>DN15</b>	1/4"	1/4"
	<b>DN20 - DN25</b>	1/2"	1/2"
	<b>DN32 - DN40</b>	1"	3/4"
	<b>DN50 - DN125</b>	1 1/4"	3/4"
	<b>DN150 - DN200</b>	2"	3/4"

## 2.3 Pressure / temperature limits

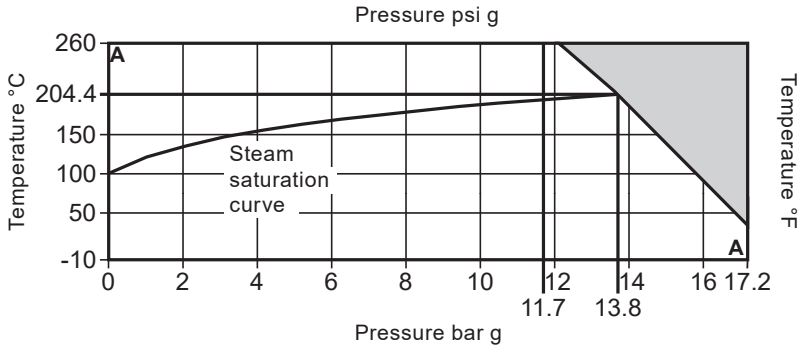

 The product **must not** be used in this region.

**A - A** Flanged ASME 150

Body design conditions		ASME 150
PMA	Maximum allowable pressure	17.2 bar g @ 37.8 °C (249.5 psi g @ 100 °F)
TMA	Maximum allowable temperature	260 °C @ 11.7 bar g (500 °F @ 169.7 psi g)
Minimum operating temperature		-10 °C (14 °F)
Designed for a maximum cold hydraulic test pressure of:		25.8 bar g (374.2 psi g)

## 2.4 Body marking information

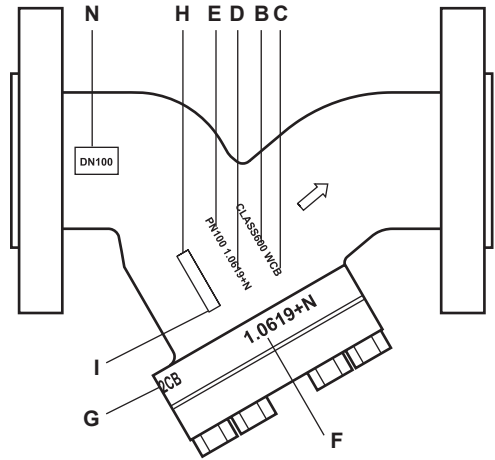

Part	Material						
	Body					Cover	
	A	B	C	D	E	F	G
Fig 37	Fig 37	GGG.40	ASME 150	ASME 150		C22.8	A105N
			ASME 150 (DN125-DN200)	EN JS1030		1.0619+N	WCB

## 3. Installation

**Note:** Before actioning any installation observe the 'Safety information' in Section 1.

Referring to the installation and Maintenance Instructions, name-plate and Technical Information Sheet, check that the product is suitable for the intended installation:

- 3.1** Check materials, pressure and temperature and their maximum values. If the maximum operating limit of the product is lower than that of the system in which it is being fitted, ensure that a safety device is included in the system to prevent overpressurisation.
- 3.2** Determine the correct installation situation and the direction of fluid flow.
- 3.3** Remove protection covers from all connections and protective film from all name-plates, where appropriate, before installation on steam or other high temperature applications.
- 3.4** Strainers can be fitted on liquid or steam/gas systems in either horizontal pipework or vertical pipework where the flow is downward. In a horizontal line on steam/gases the strainer pocket should be in the horizontal plane as this reduces the possibility of waterhammer. On liquid systems the strainer pocket should point downwards.
- 3.5** The strainers may be lagged if required.



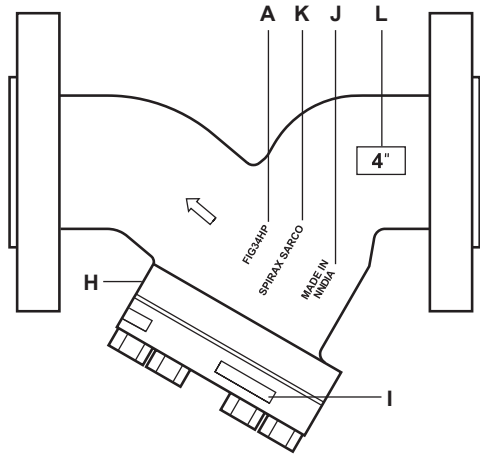

Foundry identification	Melt number	Made in India	SPIRAX SARCO or SXS or SPIRAX	DN
H	I	J	K	L
.	.	.	.	.
.	.	.	.	.

## 4. Commissioning

After installation or maintenance ensure that the system is fully functional. Carry out tests on any alarms or protective devices.

## 5. Operation

Strainers are passive items and will prevent the onward movement of dirt and debris, which is larger than the holes in the screen. The pressure drop across the strainer will increase as the screen becomes blocked. Regular cleaning / blowdown is recommended to keep the screen clean.

# 6. Fault finding

Symptom	Possible cause	Remedy
No flow through strainer	Blocked screen	Clean or replace screen See Section 7.2
	System is isolated	Check isolation valves
Increased pressure drop across strainer	Screen is blocked up	Clean or replace screen See Section 7.2

Strainer installed on steam or gas

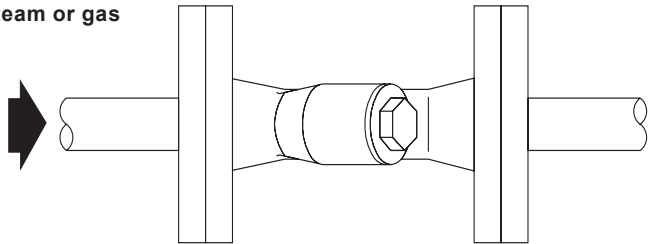

Strainer installed on liquid

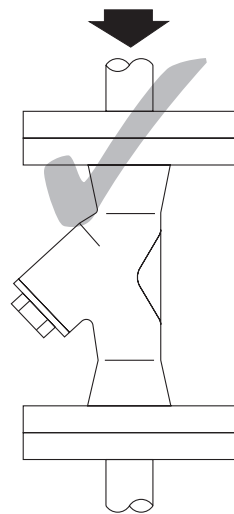
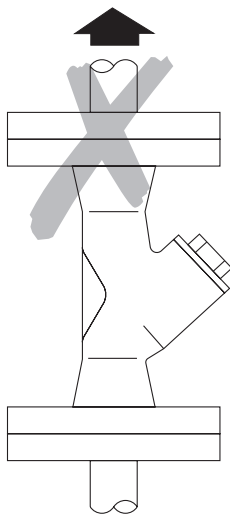
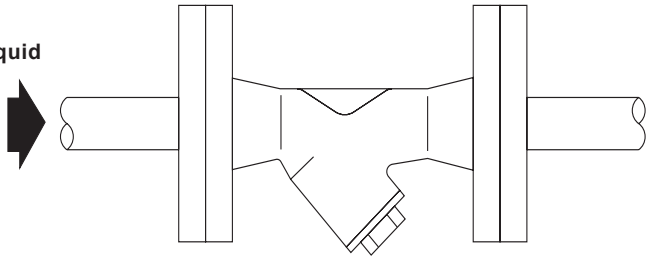

# 7. Maintenance

**Note:** Before actioning any maintenance programme observe the 'Safety information' in Section 1.

## Warning

The cover gasket contains a thin stainless steel support ring which may cause physical injury if not handled and disposed of carefully.

### 7.1 General information



Before undertaking any maintenance on the strainer, it must be isolated from both the supply line and return line and any pressure allowed to safely normalise to atmosphere. The trap should then be allowed to cool. When reassembling, ensure that all joint faces are clean.

### 7.2 How to clean or replace the strainer screen:

For identification of parts refer to Section 8 'Spare parts'

- Remove the strainer cap.
- On most sizes up to DN25 the cap is simply unscrewed.
- On all other sizes the cap is retained by bolts/nuts. The number of bolts/nuts used will depend on the strainer size, material of construction and design rating.
- Once the cap is removed the strainer screen can be taken out.
- Clean the screen or replace with a new one.
- Reassemble the screen into the cap by pushing the end into the recess.
- Always fit a new strainer cap gasket ensuring the jointing faces are clean.
- Refit the strainer cap or bolts/nuts using 'Neverseize' compound and tighten to the recommended torque (refer to the relevant Table on page 12).
- Ensure that the nuts are tightened equally before final torque is applied.
- Check for leaks.

**Table 1 - Recommended tightening torques**

Item	Qty	Size		or mm		N m	(lbf ft)
	1	DN15	22 A/F	M28		50 - 55	(37 - 40)
	1	DN20	27 A/F	M32		60 - 66	(44 - 49)
	1	DN25	27 A/F	M42		100 - 110	(74 - 81)
	1	DN32	46 A/F	M56		250 - 275	(184 - 202)
	1	DN40	50 A/F	M60		250 - 275	(184 - 202)
5	1	DN50	60 A/F	M72		310 - 340	(228 - 250)
	8	DN65	19 A/F	M12 x 35		20 - 24	(15 - 18)
	8	DN80	19 A/F	M12 x 35		30 - 35	(19 - 26)
	8	DN100	24 A/F	M16 x 45		50 - 55	(37 - 40)
	8	DN125	30 A/F	M20 x 50		80 - 88	(59 - 65)
	8	DN150	30 A/F	M20 x 55		100 - 110	(74 - 81)
	12	DN200	36 A/F	M24 x 65		090 - 100	(66 - 74)

# 8. Spare parts

The only parts that are available as spares are detailed in the table below.

## Available spares

Strainer screen (state material, mesh, perforation and size of strainer)	4
Cap gasket (packet of three)	3

## How to order spares

Always order spares by using the description given in the column headed 'Available spares' and state the size and type.

**Example:** 1 off 100 mesh stainless steel screen for a DN100 Fig 34 steel strainer.

