

**Spirax SafeBloc™ DBB3 Double Block and Bleed
Bellows Sealed Stop Valve
Installation and Maintenance Instructions**

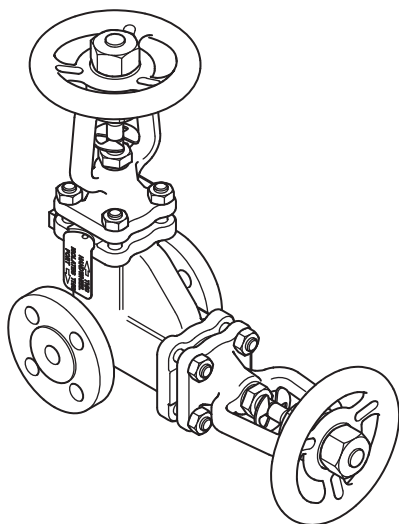

- 1. Safety information*
- 2. General
product information*
- 3. Installation*
- 4. Commissioning*
- 5. Operation*
- 6. Maintenance*
- 7. Spare parts*

1. Safety information

Safe operation of these products can only be guaranteed if they are properly installed, commissioned, used and maintained by qualified personnel (see Section 1.11) in compliance with the operating instructions. General installation and safety instructions for pipeline and plant construction, as well as the proper use of tools and safety equipment must also be complied with.

Warning

The body/bonnet gaskets (11a and 11b, page 11) contain a thin stainless steel support ring which may cause physical injury if not handled and disposed of carefully.

1.1 Intended use

Referring to the Installation and Maintenance Instructions, name-plate and Technical Information Sheet, check that the product is suitable for the intended use/application. The product listed below complies with the requirement of the European Pressure Equipment Directive 97/23/EC and carries the CE mark when so required. It should be noted that products that are in category 'SEP' are required by the Directive not to carry the CE mark.

Product		Group 1 Gases	Group 2 Gases	Group 1 Liquids	Group 2 Liquids
Spirax SafeBloc™	PN40	DN15 - DN25	SEP	SEP	SEP
		DN40 - DN50	2	1	SEP
		DN65 - DN100	2	1	2
	ANSI 300	DN15 - DN25	SEP	SEP	SEP
		DN40 - DN100	2	1	2

- i) This product has been specifically designed for use on propane or methane gases, which are in Group 1 of the above mentioned Pressure Equipment Directive. It can also be used on steam, air or water/condensate which are in Group 2 of the above mentioned Pressure Equipment Directive. The products' use on other fluids may be possible but, if this is contemplated, Spirax Sarco should be contacted to confirm the suitability of the product for the application being considered.
- ii) Check material suitability, pressure and temperature and their maximum and minimum values. If the maximum operating limits of the product are lower than those of the system in which it is being fitted, or if malfunction of the product could result in a dangerous overpressure or overtemperature occurrence, ensure a safety device is included in the system to prevent such over-limit situations.
- iii) A number of products are supplied for the intention of the end user (or agent thereof) modifying the flange configuration from that supplied. It is the responsibility of the organization carrying out the modification to do so in accordance with the internationally recognized standards and to ensure that the design rating and operation of the product are not compromised. Spirax Sarco will not be held responsible for any unapproved modification or consequential liability resulting in failure to observe these requirements.
- iv) Determine the correct installation situation and direction of fluid flow.
- v) Spirax Sarco products are not intended to withstand external stresses that may be induced by any system to which they are fitted. It is the responsibility of the installer to consider these stresses and take adequate precautions to minimise them.

-
- vi) Remove protective covers from all connections and protective film from all name-plates, where appropriate, before installation on steam or other high temperature applications.

1.2 Access

Ensure safe access and if necessary a safe working platform (suitably guarded) before attempting to work on the product. Arrange suitable lifting gear if required.

1.3 Lighting

Ensure adequate lighting, particularly where detailed or intricate work is required.

1.4 Hazardous liquids or gases in the pipeline

Consider what is in the pipeline or what may have been in the pipeline at some previous time. Consider: flammable materials, substances hazardous to health, extremes of temperature.

1.5 Hazardous environment around the product

Consider: explosion risk areas, lack of oxygen (e.g. tanks, pits), dangerous gases, extremes of temperature, hot surfaces, fire hazard (e.g. during welding), excessive noise, moving machinery.

1.6 The system

Consider the effect on the complete system of the work proposed. Will any proposed action (e.g. closing isolation valves, electrical isolation) put any other part of the system or any personnel at risk?

Dangers might include isolation of vents or protective devices or the rendering ineffective of controls or alarms. Ensure isolation valves are turned on and off in a gradual way to avoid system shocks.

1.7 Pressure systems

Ensure that any pressure is isolated and safely vented to atmospheric pressure. Consider double isolation (double block and bleed) and the locking or labelling of closed valves. Do not assume that the system has depressurised even when the pressure gauge indicates zero.

1.8 Temperature

Allow time for temperature to normalise after isolation to avoid danger of burns.

1.9 Tools and consumables

Before starting work ensure that you have suitable tools and/or consumables available. Use only genuine Spirax Sarco replacement parts.

1.10 Protective clothing

Consider whether you and/or others in the vicinity require any protective clothing to protect against the hazards of, for example, chemicals, high/low temperature, radiation, noise, falling objects, and dangers to eyes and face.

1.11 Permits to work

All work must be carried out or be supervised by a suitably competent person. Installation and operating personnel should be trained in the correct use of the product according to the Installation and Maintenance Instructions.

Where a formal 'permit to work' system is in force it must be complied with. Where there is no such system, it is recommended that a responsible person should know what work is going on and, where necessary, arrange to have an assistant whose primary responsibility is safety.

Post 'warning notices' if necessary.

1.12 Handling

Manual handling of large and/or heavy products may present a risk of injury. Lifting, pushing, pulling, carrying or supporting a load by bodily force can cause injury particularly to the back. You are advised to assess the risks taking into account the task, the individual, the load and the working environment and use the appropriate handling method depending on the circumstances of the work being done.

Although the bonnet and handwheel will support the weight of the valve, it is recommended the slings for lifting are positioned around the back of the pipe flanges on the main body.

1.13 Residual hazards

In normal use the external surface of the product may be very hot. If used at the maximum permitted operating conditions the surface temperature of some products may reach temperatures of 400°C (752°F).

Many products are not self-draining. Take due care when dismantling or removing the product from an installation (refer to 'Maintenance instructions').

1.14 Freezing

Provision must be made to protect products which are not self-draining against frost damage in environments where they may be exposed to temperatures below freezing point.

1.15 Disposal

Unless otherwise stated in the Installation and Maintenance Instructions, this product is recyclable and no ecological hazard is anticipated with its disposal providing due care is taken.

1.16 Returning products

Customers and stockists are reminded that under EC Health, Safety and Environment Law, when returning products to Spirax Sarco they must provide information on any hazards and the precautions to be taken due to contamination residues or mechanical damage which may present a health, safety or environmental risk. This information must be provided in writing including Health and Safety data sheets relating to any substances identified as hazardous or potentially hazardous.

— 2. General product information —

2.1 Description

The Spirax SafeBloc™ is a double block and bleed bellows sealed stop valve, which has been designed for use as an in-line double isolation valve on steam, gas, liquid, condensate and water systems.

Available types

DBB3 steel body and bonnet with PN40 and ANSI 300 connections.

Bleed valve options

A **bleed valve connection** is provided to depressurise the downstream when the upstream valve is isolated. This can be supplied with either a DN15 flanged, ½" screwed BSP or ½" socket weld connection and must be stated at the time of order placement.

Standards

This product fully complies with the requirements of the European Pressure Equipment Directive 97/23/EC and carries the **CE** mark when so required.

Certification

This product is available with certification to EN 10204 3.1. **Note:** All certification/inspection requirements must be stated at the time of order placement.

Note: For additional information see Technical Information Sheet, TI-P184-08.

2.2 Sizes and pipe connections

DN15, DN20, DN25, DN40, DN50, DN65, DN80 and DN100 flanged EN 1092 PN40 and ANSI B 16.5 Class 300.

Face-to-face dimensions conform to EN 558-1 (PN) and EN 558-2 (ANSI class).

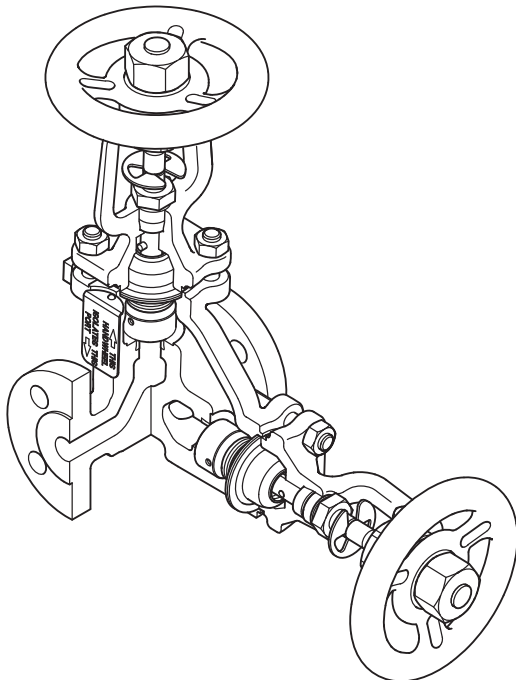
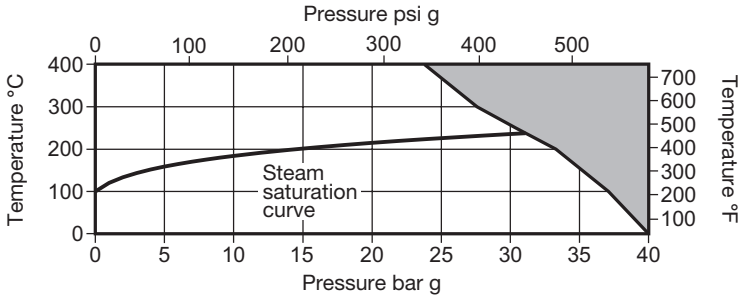

Fig. 1

2.3 Pressure/temperature limits (ISO 3552)

PN40



The product **must not** be used in this region.

Body design conditions		PN40	
PMA	Maximum allowable pressure	40 bar g @ 0°C	(580 psi g @ 32°F)
TMA	Maximum allowable temperature	400°C @ 24 bar g	(752°F @ 348 psi g)
	Minimum allowable temperature	-10°C	(14°F)
PMO	Maximum operating pressure for saturated steam service	30.4 bar g	441 (523°F)
TMO	Maximum operating temperature	400°C @ 24 bar g	(752°F @ 348 psi g)
	Minimum operating temperature	-10°C	(14°F)
Note: For lower operating temperatures consult Spirax Sarco			
Designed for a maximum cold hydraulic test pressure of:		60 bar g	(870 psi g)

ANSI 300

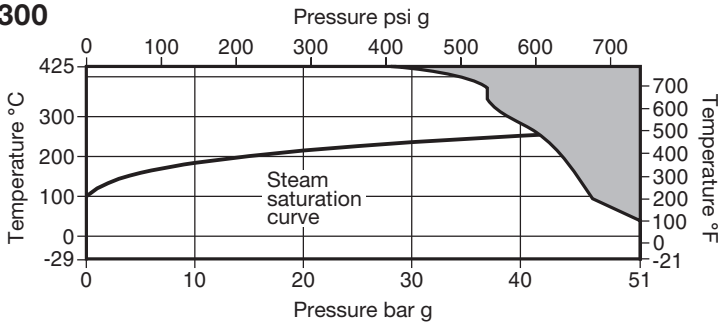

The product **must not** be used in this region.

Body design conditions		ANSI 300	
PMA	Maximum allowable pressure	51 bar g @ 37.7°C	(739 psi g @ 100°F)
TMA	Maximum allowable temperature	425°C @ 28 bar g	(797°F @ 406 psi g)
	Minimum allowable temperature	-29°C	(-20°F)
PMO	Maximum operating pressure for saturated steam service	41.6 bar g	(603 psi g)
TMO	Maximum operating temperature	425°C @ 28 bar g	(797°F @ 406 psi g)
	Minimum operating temperature	-29°C	(-20°F)
Note: For lower operating temperatures consult Spirax Sarco			
Designed for a maximum cold hydraulic test pressure of:		77 bar g	(1117 psi g)

3. Installation

Note: Before actioning any installation observe the ‘Safety information’ in Section 1.

Referring to the Installation and Maintenance Instructions, name-plate and Technical Information Sheet, check that the product is suitable for the intended installation:

- 3.1** Check materials, pressure and temperature and their maximum values. If the maximum operating limit of the product is lower than that of the system in which it is being fitted, ensure that a safety device is included in the system to prevent overpressurisation.
- 3.2** Remove protective covers from all connections, threaded blanking plug from the bleed port (screwed and socket weld version only) and the protective film from all name-plates, where appropriate, before installation on steam or other high temperature applications. A suitable form of isolation must be fitted to the bleed port before commissioning of the line.

- 3.3** The valve can be installed in the horizontal or vertical plane. When installed in the horizontal plane the bleed port should ideally be positioned at the bottom (see Figure 2). Isolation of the bleed port should be positioned as close to the valve as possible to avoid back-up of condensate in the isolated bleed line. The bleed port connection must be piped to a safe visible atmospheric place as close to the valve as possible.

Please note there is no flow direction arrow on the valve as it can be installed with flow from right to left or left to right.

- 3.4** When installed on steam systems a suitable steam trap should be fitted immediately upstream of the isolation valve to drain condensate. This will ensure drainage of the pipe when the valve is closed, and will prevent damage of the valve due to waterhammer. The drain trap should be either a ball float (FT) or thermodynamic (TD) type. Correct condensate drainage of all upstream pipework is also vital.

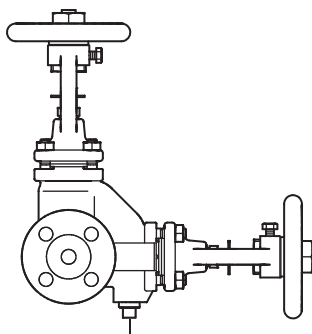

Bleed point

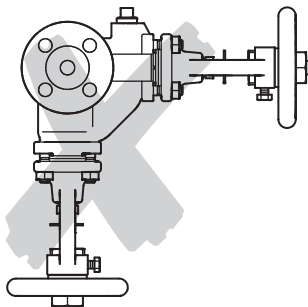
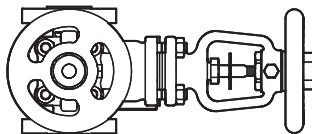
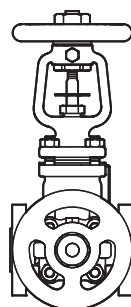

Fig. 2 Incorrect Installation



Correct Installation

4. Commissioning

After installation or maintenance ensure that the system is fully functional. Carry out tests on any alarms or protective devices.

5. Operation

5.1 The bellows sealed isolation valve plays an important role in the conservation of energy by eliminating fugitive stem seal emissions.

5.2 The valve is operated manually by handwheels. Special care must be taken to ensure that the movement is made in the correct direction.

To open the valves fully, it is recommended to turn the handwheels until the shafts are raised to the maximum position, indicated by the (+) on the bonnet, then turn the handwheel clockwise $\frac{1}{8}$ to $\frac{1}{4}$ turn to remove any backlash. This action prevents any force being applied to open a valve, which is already fully open, resulting in damage to the stem, bellows unit or other components. Spirax Sarco bellows sealed isolation valves are fitted with a position indicator, which can be found on the stem, and should align with the (+) or (-) on the bonnet support pillars. (+ = fully open and - = fully closed).

5.3 If valve 'keys' are used care must be taken not to use excessive force when opening or closing the valve.

5.4 A Valve Integrity Test must be undertaken prior to each double isolation of the system. Refer to Figure 3 and the Table below for correct sequence of operation.

Flow from Left to Right (L-R)	Flow Right to Left (R-L)
1. All valves closed	1. All valves closed.
2. Open bleed/drain valve C .	2. Open bleed/drain valve C .
3. Open downstream valve B .	3. Open downstream valve A .
4. Upstream valve A should remain closed.	4. Upstream valve B should remain closed.
5. After initial discharge of downstream depressurisation from the bleed valve C , no further steam/fluid should be observed (integrity proved). If fluid is observed check valve A is fully closed, if fluid is still evident contact Spirax Sarco and Do Not Use .	5. After initial discharge of downstream depressurisation from the bleed valve C , no further steam/fluid should be observed (integrity proved). If fluid is observed check valve B is fully closed, if fluid is still evident contact Spirax Sarco and Do Not Use .

It is advisable to place a copy of the above table in close proximity of the Spirax SafeBloc™ valve.

5.5 Before undertaking any maintenance of plant downstream of the valve both handwheels should be isolated. Refer to Figure 3 and the Table below for the correct sequence of handwheel operation.

When handwheels **A** and **B** are closed and drain port **C** is opened there will be an initial discharge as the valve depressurises. If there should be any visible discharge after a short period, consult Spirax Sarco Service Department.

Note: Handwheels should always be opened slowly to avoid system shocks.

Operation sequence for the Spirax SafeBloc™ Flow Left to Right (L-R)		Operation sequence for the Spirax SafeBloc™ Right to Left (R-L)	
Isolation	Opening	Isolation	Opening
Close A	Close C	Close B	Close C
Open C	Open B	Open C	Open A
Close B	Open A	Close A	Open B

For illustrative purposes refer to Steps 1 to 5 on pages 10 and 11.

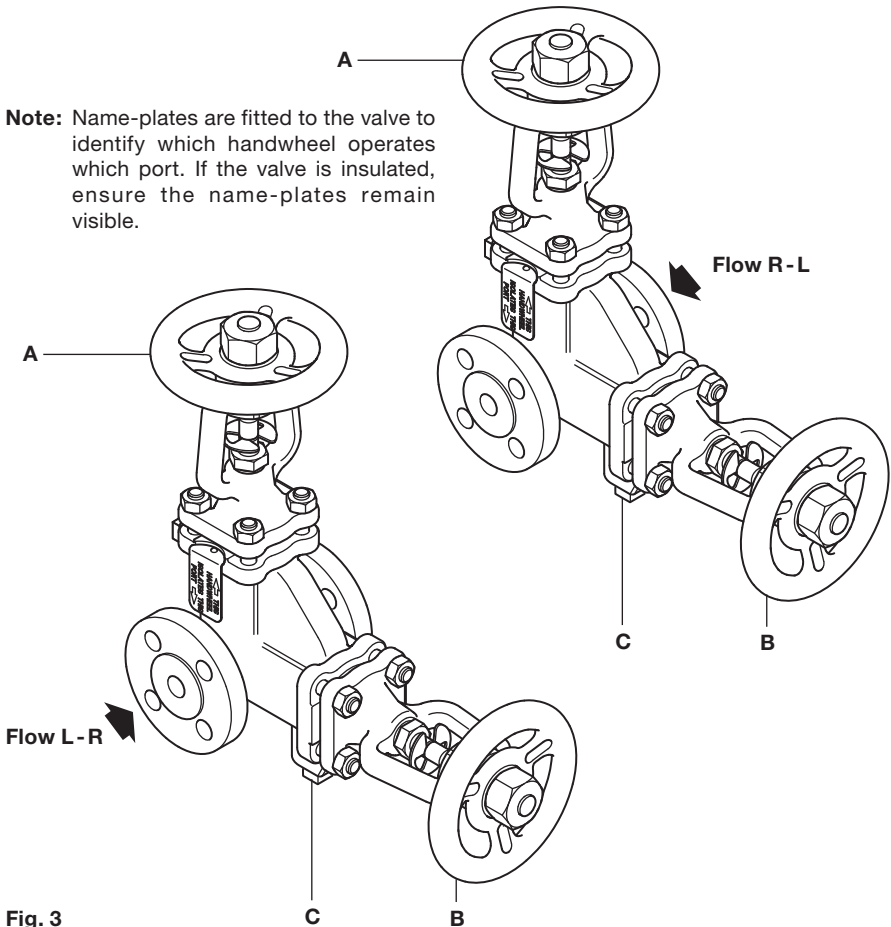

Fig. 3

6. Maintenance

Note: Before actioning any maintenance programme observe the 'Safety information' in Section 1.

Warning

The body/bonnet gaskets (11a and 11b) contain a thin stainless steel support ring which may cause physical injury if not handled and disposed of carefully.

6.1 General information

Before undertaking any maintenance on the valve, ensure any pressure is isolated and safely vented to atmospheric pressure. The valve should then be allowed to cool. When reassembling, ensure that all joint faces are clean.

Ensure that the correct tools and necessary protective equipment are used at all times. When maintenance is complete open isolation valves slowly and check for leaks.

Note: The bonnet bush and threads of the stem are packed with a high quality grease on assembly. It is recommended to re-grease these items whenever maintenance is undertaken on the valve.

6.2 Sequence of operation for safe maintenance of plant

Please note: that all the drawings in Steps 1 to 5 are illustrated with the flow direction from left to right.

Key  = Valve open  = Valve closed

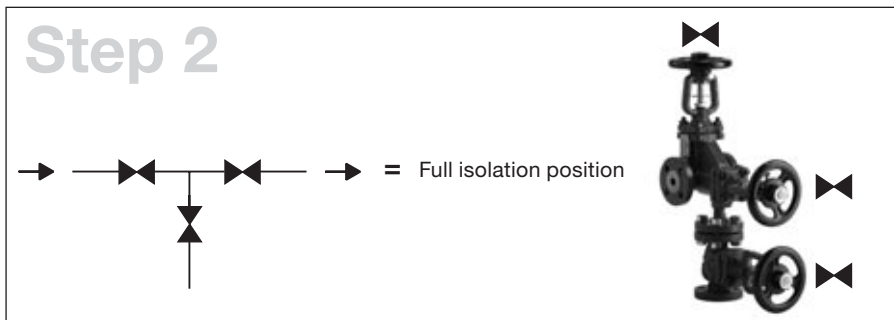
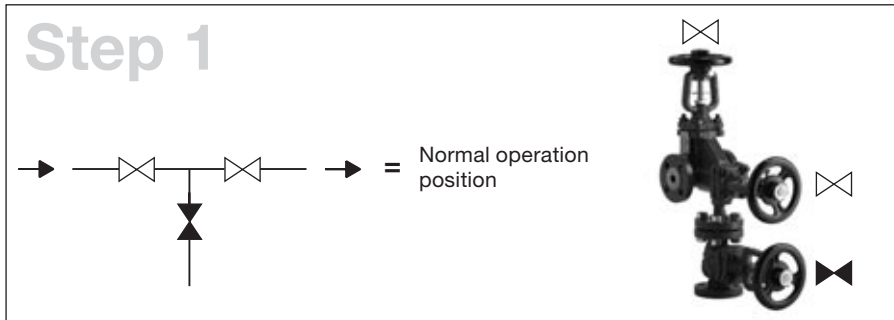

Step 3

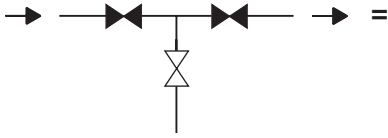

Depressurise the valve body and establish isolation integrity



Step 4

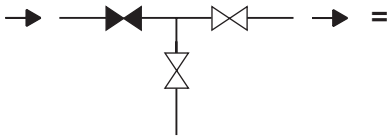

Depressurise the downstream system



Step 5

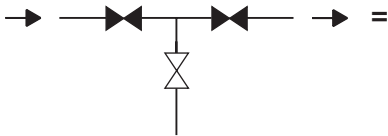

It is now safe to maintain the downstream system



Return to Step 1

Please note: The Spirax SafeBloc™ is shown with the bellows sealed bleed valve option. Other bleed arrangements are available on request.

6.3 Handwheel

The handwheel (7) is not supplied as a spare part. However, to remove the handwheel unscrew the main handwheel nut in a clockwise direction.

Place a suitable spanner (a detailed drawing is available from Spirax Sarco) across the flats of the bonnet bush (2) and unscrew the handwheel in the normal way.

Note: the handwheel may be firmly secured on the bonnet bush (2). Refitting the handwheel is the opposite to removal. Apply Loctite 638 to the threads of the handwheel boss and tighten to 50 N m (36 lbf ft). Remember to tighten the handwheel nut to 40 N m (29 lbf ft) in an anticlockwise direction.

6.4 How to fit the body/bonnet gaskets

This can be carried out whilst the valve is connected in the pipeline:

- Remove the valve bonnet (2) from the body (1) by unscrewing the bonnet studs/nuts (9 and 10). The body gasket (11b) is now visible and can quickly be replaced. Ensure the gasket face in the body (1) is clean before fitting a replacement.
- To replace the second gasket (11a) which is situated between the bonnet (2) and the stainless steel bellows support collar, firstly remove the clip-on position indicator and remove the locking screw. Rotate the handwheel (7) in a clockwise direction. This pushes the main stem (6) downwards and creates a gap between the bellows support collar and the bonnet (2). If the support collar remains attached to the bonnet (2), gently prise the collar away from the bonnet being careful not to damage the collar. **Do not allow the bellows to stretch as this can reduce the bellows life.**
- By continually rotating the handwheel (7) in a clockwise direction, the stem (6) can be unscrewed from the bonnet bush. When the stem (6) is disconnected from the bonnet bush, unscrew the gland nut and remove both this and the gland washer. Keep these parts safe as they are not supplied as spares. The stem / bellows assembly (6 and 5) can now be withdrawn out of the bonnet (2). The second bellows collar gasket (11a) can now be replaced - ensuring both the bellows support collar surface and bonnet surface are clean and the gasket is accurately located. Before the stem / bellows assembly (6 and 5) is reassembled into the bonnet (2), the stem packing ring (8) should be replaced (see Section 6.5).

6.5 How to fit the stem packing

By following through Section 6.3 it is now possible to replace the stem packing ring (8):

- Two stem packing rings are provided in the spares kit but only one is required.
- Ensure all of the old stem packing material is removed from the bonnet cavity and all locating surfaces are clean.
- Valve assembly is the opposite to removal - remembering to fit a bellows collar gasket (11a) between the bellows support collar and the valve bonnet (2).
- Slide the stem (6) through the bottom of the valve bonnet (2). Locate the new stem packing ring (8), original gland washer and the gland nut over the stem. **Do not allow the stem thread to damage the inner surface of the gland packing ring (8).** Screw the end of the stem into the bonnet bush at the top of the valve bonnet. Ensure the solid stem pin (which is pressed into the stem (6) is aligned with the slot inside the bonnet.
- Carefully slide the new packing ring (8) down the stem into the cavity and slide the original gland washer on top of the packing ring (8).
- After the valve has been fully assembled remember to create a safe seal between the gland packing ring (8) and the stem (6) by tightening down the gland nut to the recommended tightening torque (see Table 1).

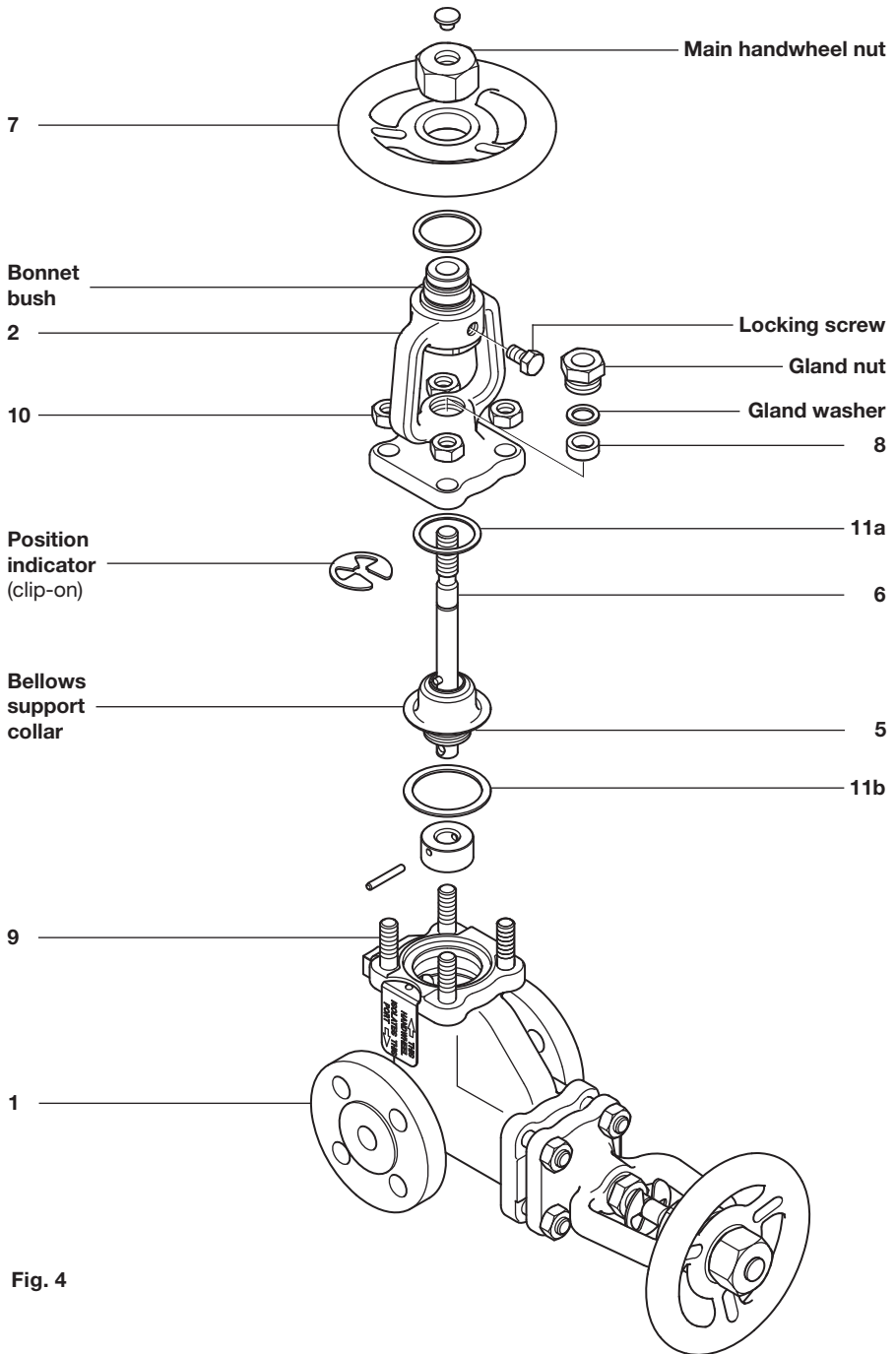

Fig. 4

6.6 How to fit the stem and bellows assembly

By following through Section 6.5 it is now possible to fit a new stem/bellows assembly (6, 5):

- Fitting this is opposite to removal - remembering to fit a bellows collar gasket (11a) between the bellows support collar and valve bonnet (2).
- Ensure the bellows collar gasket (11a) is accurately located. Before fitting the new stem/bellows assembly (6 and 5) into the bonnet (2).
- Apply a small amount of lubricating compound such as Gulf Sovereign LC grease to the end of the stem pin (which is pressed into the stem).
- Ensure the stem pin is aligned with the slot inside the bonnet.
- Carefully slide the stem up through the bonnet.
- Before screwing the end of the stem into the bonnet bush remember to fit a new stem packing ring (8) (see Section 6.5), the original gland washer (or gland follower) and gland nut (or gland flange) over the stem (6). **Do not allow the stem thread to damage the inner surface of the gland packing ring 8.**
- Carefully slide the new packing ring (8) down the stem into the cavity and slide the original gland washer (or gland follower if fitted) on top of the packing ring (8).
- After the valve has been fully assembled remember to create a safe seal between the gland packing ring (8) and the stem (6) by tightening down the gland nut to the recommended tightening torque (see Table 1).

6.7 How to fit the disc

By following through Section 6.5 it is now possible to replace the valve's disc:

- To replace the disc (4) simply remove the old stem pin and replace the disc (4).
- Attach the new disc with the new stem pin (supplied). Where the disc (4) is attached using a retaining nut and collet arrangement, simply prise the crimped skirt away from the retaining nut and unscrew. Remove the collets remembering to save these and the retaining nut as they are not supplied as spares. Fitting is the opposite to removal but ensure the collets and threads are lightly greased with lubricating compound such as Molybdenum Sulphide.
- If a new disc is being fitted then crimp the collet retaining nut securely across two corners by deforming the disc's thin metal skirt. If the original disc is being fitted then re-crimp using a fresh part of the skirt.

6.8 Final assembly:

- Ensure the bellows support collar and gaskets (11a and 11b) are accurately aligned with the bonnet (2) before final assembly into the body (1).
- Tighten the bonnet bolts/nuts (9 and 10) evenly to the recommended tightening torque (See Table 1).

Table 1 Recommended tightening torques Nm (lbf ft)

Item	Size	 mm	PN40		ANSI 300	
			Nm	(lbf ft)	Nm	(lbf ft)
Bonnet bolts and nuts (9 & 10)	DN15 - DN25	17 A/F	35-40	(26-29)	50-55	(36-40)
	DN40 - DN65	19 A/F	55-60	(40-44)	85-90	(63-66)
	DN80 - DN100	24 A/F	130-140	(95-103)	190-200	(140-147)
Gland nut	DN15 - DN80	22 A/F	5-10	(3.5-7)	5-10	(3.5-7)
	DN100	32 A/F	15-20	(10.5-14)	15-20	(10.5-14)

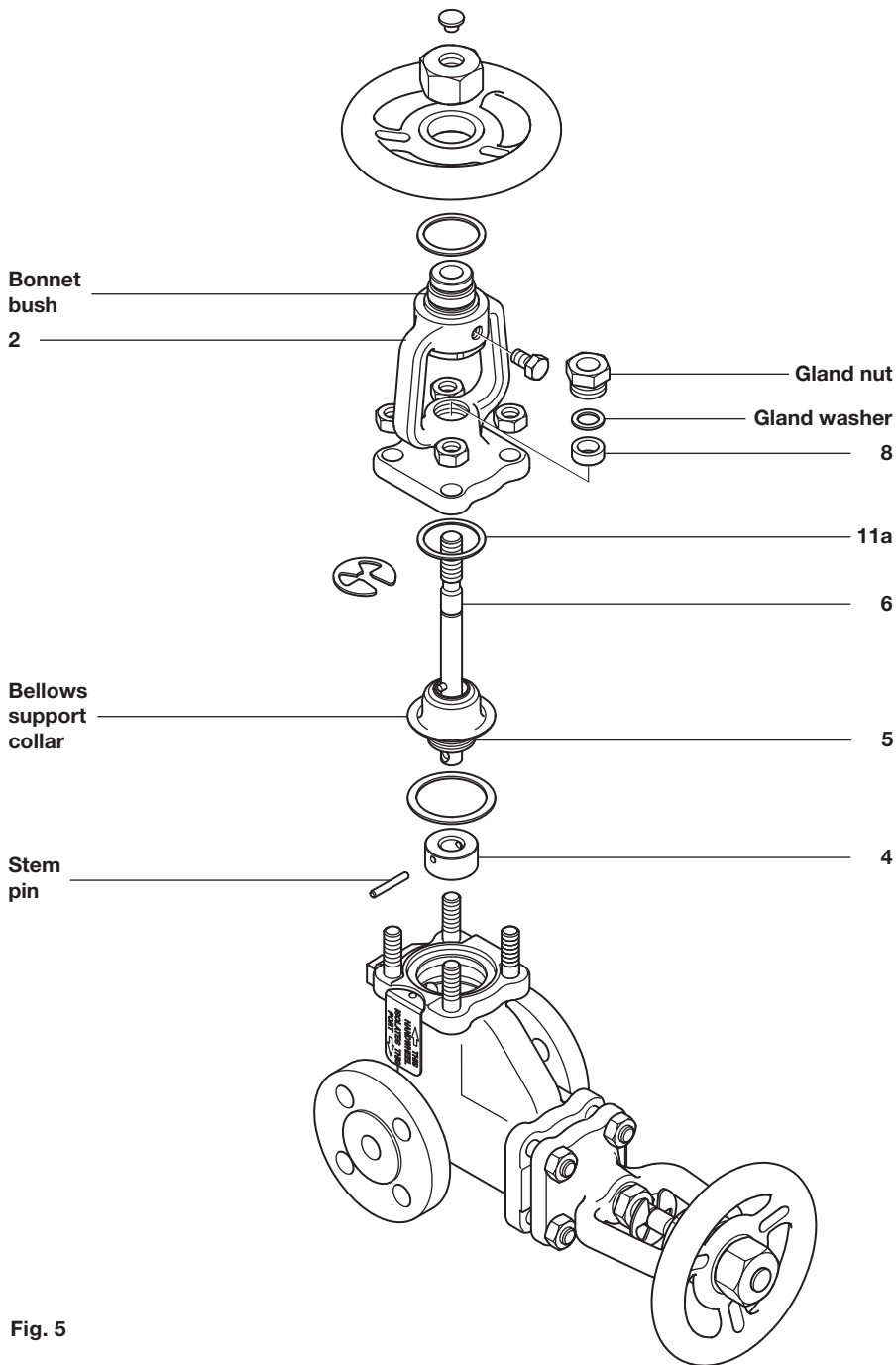

Fig. 5

7. Spare parts

The spare parts available are shown in solid outline. Parts drawn in broken line are not supplied as spares.

Available spares

Body / bonnet gasket and stem packing	8 (2 off), 11a, 11b
Stem and bellows assembly	6, 5
Disc	4

Note: The gasket contains sharp metal reinforcement, please handle with care. For a complete overhaul of the valve 2 x each spare is required.

How to order spares

Please note: for customer convenience spares are supplied in kits to ensure all the appropriate replacement parts are supplied to carry out a specific maintenance task e.g. when a stem and bellows assembly is ordered, parts (8, 11a and 11b) and (6 and 5) will be included in the kit. Always order spares by using the description given above and state the size and type of stop valve.

Example: 1 - Body/bonnet gasket and stem packing for a DN15 Spirax SafeBloc™ DBB3 double block and bleed bellows sealed stop valve having PN40 connections.

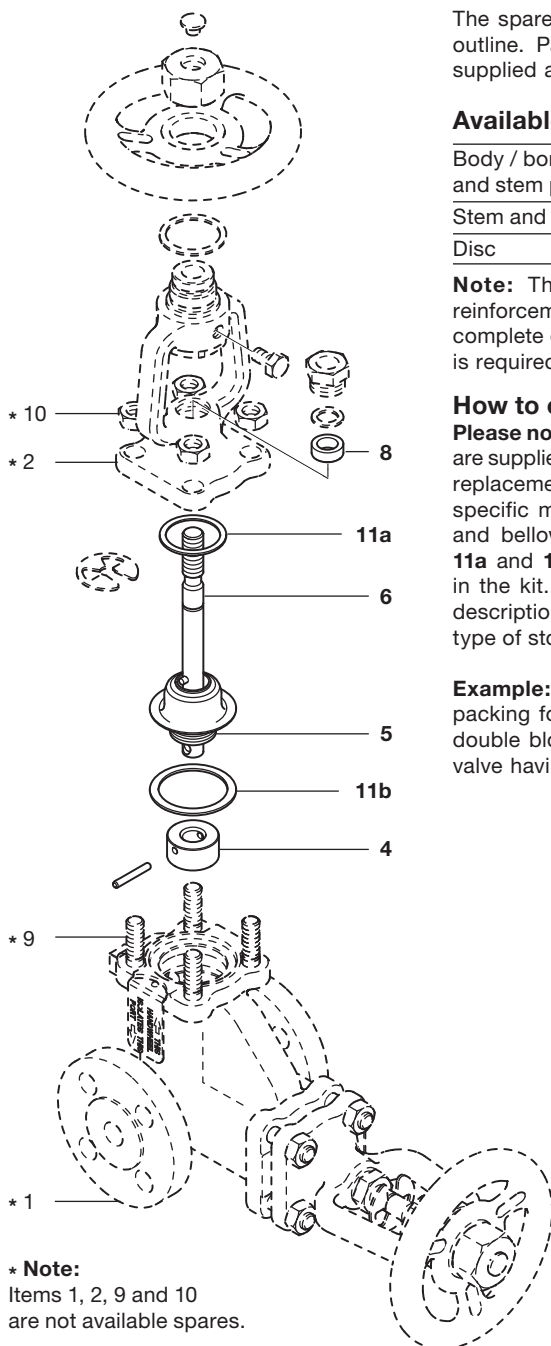

* **Note:**
Items 1, 2, 9 and 10
are not available spares.

Fig. 6