



Type 130 and HL10 'Safeguard High Limit Control'

Description

The Spirax Sarco safeguard high limit control system is supplied set to cut-out at approximately 60 °C and is designed to protect plant from overheating.

Note: the settings can easily be altered to initiate cut-out at anywhere between 0 °C and 100 °C.

The system comprises of a Type 130 control system coupled to an HL10 high limit cut-out unit complete with 2 m of capillary tube as standard. **Note:** the Type 130 control system is only suitable for use with the HL10 high limit cut-out unit.

For correct installation it is essential to use a sensor pocket (see 'Optional extras'), which can be supplied at extra cost.

The system is designed for use with any one of the following 2-port or 3-port control valves:

Available types of control valve

Note: For full technical data of the valves mentioned below see the relevant Technical Information sheet (TI).

SB, KA, KB and KC:- 2-port normally open valves (to close on temperature rise).

SBRA, KX, KY and NSRA:- 2-port normally closed valves (to open on temperature rise). **Note:** These valves must be installed in a separate bypass pipeline unimpeded by any other control valve when used with the safeguard high limit control.

TW DN25, 40 and 50:- 3-port mixing/diverting valve.

Optional extras

Capillary tube (12): In multiples of 2 m to a maximum length of 10 m.

Note: The capillary tube should be kept to a minimum to avoid the system being affected by ambient temperature.

Pockets (16): Are available in copper or stainless steel having a 3/4" BSP (BS 21 taper) or API thread. Union nipple (Y) forms the top of the pocket and carries a rubber washer (X), and gland nut (W).

Microswitch (14): This can be connected into an alarm system, using a Kopex conduit connector and flexible conduit (not supplied with the product), and can be arranged to either make or break the electrical circuit on firing of the cut-out (see the 'Current rating table' overleaf).

The microswitch has a degree of protection to IP67 (dust tight and protected against the effects of immersion) under BS 5490.

The microswitch can be added to an HL10 unit originally supplied without it by purchasing a conversion kit: which includes a conduit entry bracket and two screws for attachment.

Control valve options:

2-port:

SB, SBRA, KA, KB, KC, KX, KY or NSRA

and

3-port:

TW DN25, 40 and 50

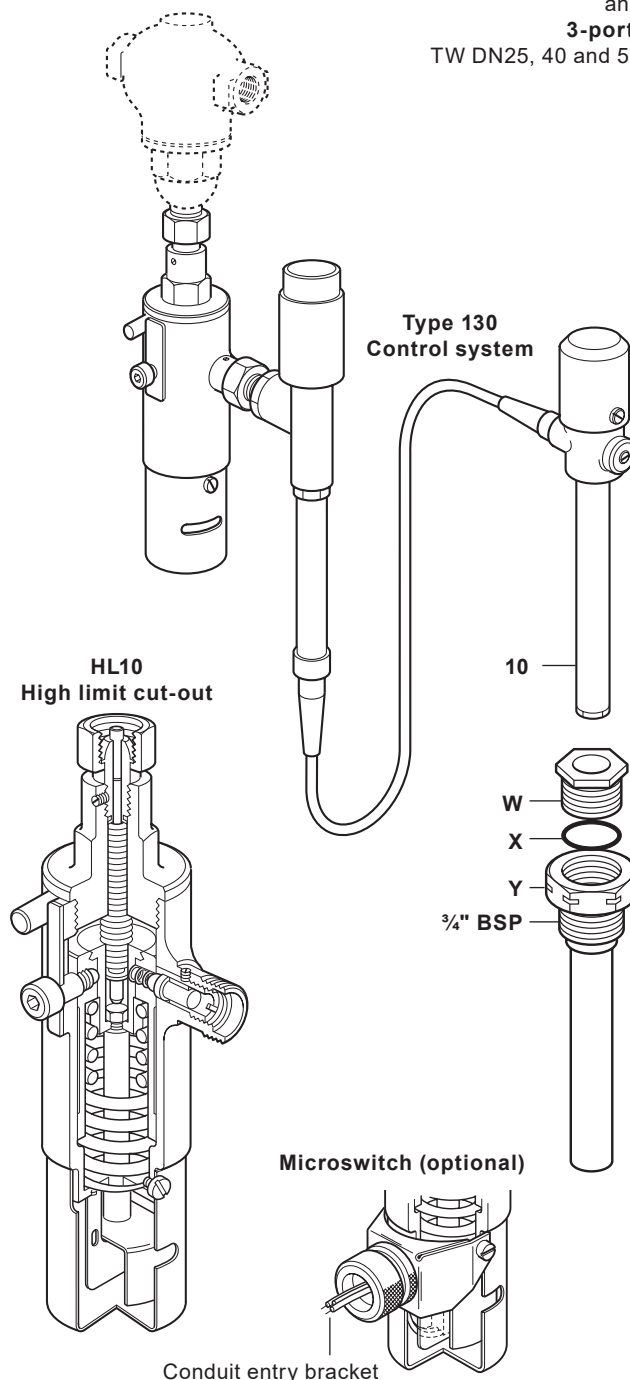

Materials

No.	Part	Material	
1	Body	Bronze	BS 1400 LG2
2	Main spring	Stainless steel	BS 2056 302 S26
3	Piston	Stainless steel	BS 970 431 S29
4	Ball	Stainless steel	AISI 440 B
5	Ball return spring	Stainless steel	BS 2056 302 S26
6	Bellows	Stainless steel	AISI 316L
7	Piston insert	Stainless steel	BS 970 431 S29
8	Bonnet	Brass	BS 2872 CZ 122
9	Valve coupling nut	Brass	BS 2872 CZ 122
10	Sensor	Brass	EN 12451 CW707R H130/170
11	Actuator	Stainless steel	BS 3605 CFS 316S18
12	Capillary tube	PVC covered copper	
13	Adjustment head cover	Polypropylene plastic	

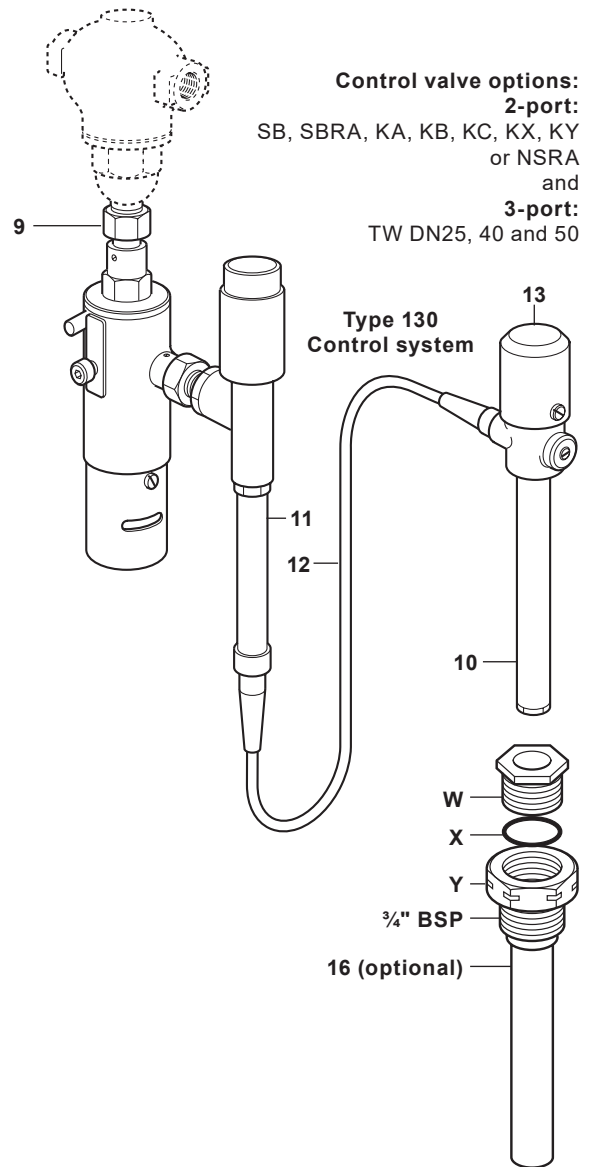
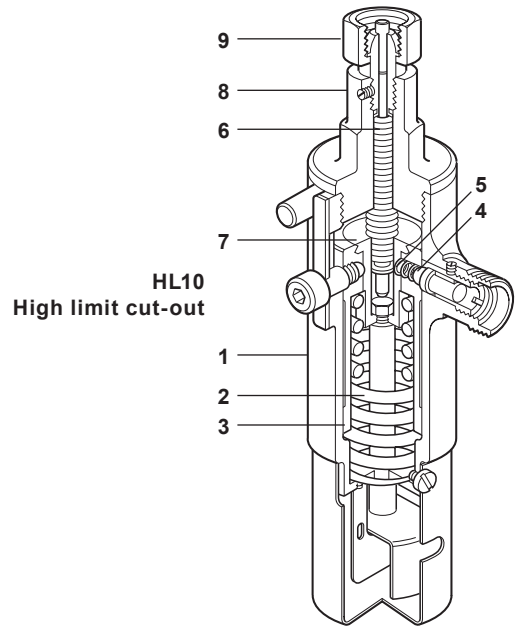

Materials for optional extras

No.	Part	Material	
14	Microswitch		
15	Cover	Aluminium	BS 1470 1200 H2
		Copper	BS 2871 C 106
16	Pocket	Mild steel	BS 980 CEW-2
		Stainless steel	BS 3605 CFS 316S18

Microswitch (optional)

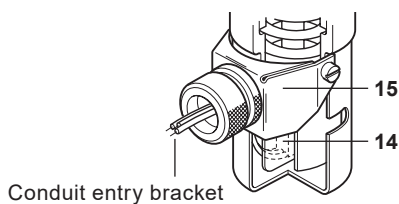

Dimensions (approximate) in mm

Weights (approximate) in kg

Control valve options:
2-port:
 SB, SBRA, KA, KB, KC, KX, KY or NSRA
 and
3-port:
 TW DN25, 40 and 50

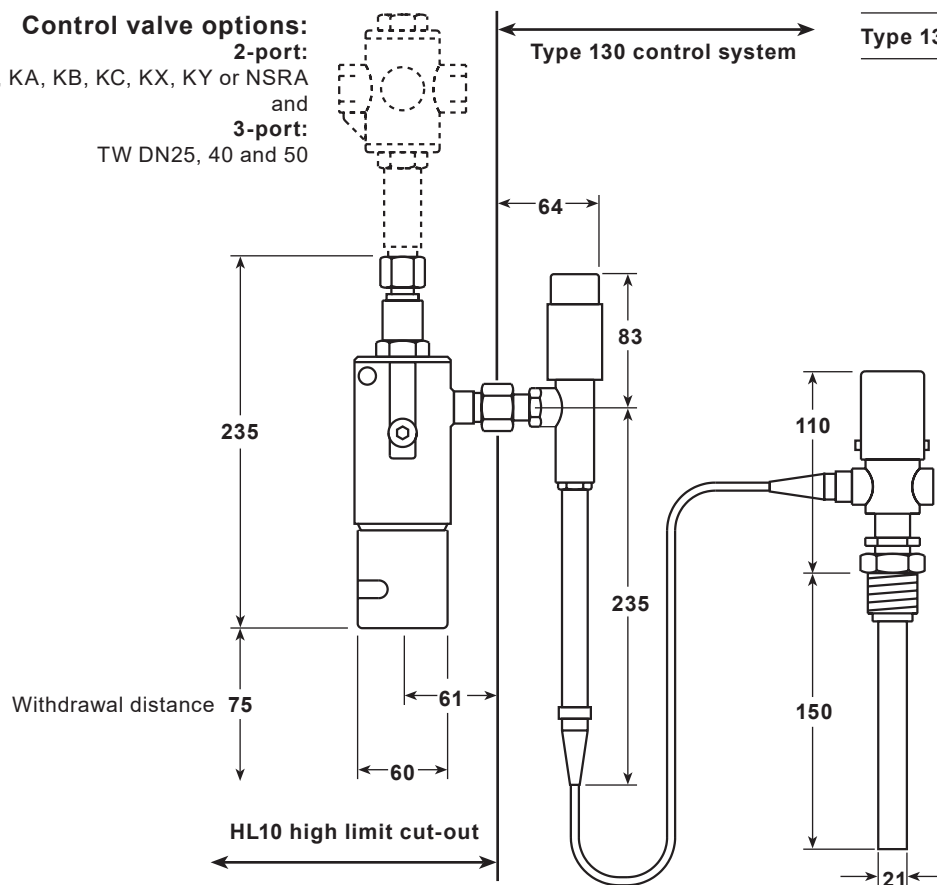

HL10 high limit cut-out unit	2.2
Type 130 control system	1.7

Current rating table - Microswitch

Voltage	Load amps	
	Resistive	Inductive
125 Vac	5	5
250 Vac	5	5
up to 15 Vdc	10	10
30 Vdc	5	3
50 Vdc	1	1
75 Vdc	0.75	0.25
125 Vdc	0.50	0.06
250 Vdc	0.25	0.03

Safety information, installation and maintenance

For full details see the Installation and Maintenance Instructions (IM-P073-08) supplied with each unit.

How to order

Example: 1 off Spirax Sarco Type 130 and HL10 safeguard high limit control complete with 2 metres of capillary tubing for fitment to SA 2 or 3-port valves, inclusive of a microswitch for the HL10 and a stainless steel pocket threaded 3/4" BSP for the sensor.

Spare parts

The spare parts available are shown in heavy outline. Parts drawn in broken line are not supplied as spares.

Available spares

Microswitch assembly	A, B (2 off)
Conversion kit	A, B (2 off), C (2 off), D
Pack of warning labels	(6 off)

How to order spares

Always order spares by using the description given in the column headed 'Available spares' and state the type of high limit cut-out.

Example: 1 - Microswitch assembly for a Spirax Sarco HL10.

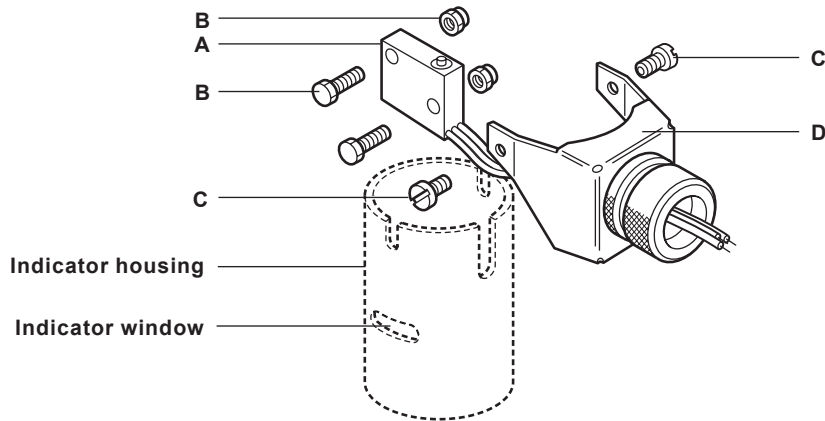

Note : A label will be affixed to the outside of the indicator housing for record purposes.