



TI-P222-02
 CH Issue 2

Turflow Type Heat Exchanger EVC (Exhaust Vapour Condenser)



Description

The Spirax Sarco EVC is based on the Turflow heat exchanger with an additional connection and utilises flash steam from discharge and exhaust vent pipework to pre-heat make-up or process water thereby recovering valuable heat energy that would otherwise be lost to atmosphere.

The Spirax Sarco EVC will improve steam system efficiency and is environmentally friendly, reducing CO₂ + carbon emissions and removing visible discharges from the atmosphere whilst saving valuable energy. It is easy to install and provides an optimised heat transfer solution when compared to other heat exchanger designs used in similar applications.

As standard the construction is completely stainless steel and the tube side is all in AISI 316. There are no gaskets (with the exception of the piping connection) and no painted components.

The heat-exchanging surface is of straight corrugated tubes designed for low viscosity fluids and for turbulent flow working conditions. The tube sheets are of an integral type and are supplied ready for installation.

Standards

Designed and manufactured in accordance with the 'Raccolta VSR Revision 1995 Edition 99' code and fully complies with the requirements of the European Pressure Equipment Directive 97/23/EC.

Certification

This product is available with a manufacturers Typical Test Report.

Note: All certification/inspection requirements must be stated at the time of order placement.

Available models

Heat exchanger	Steam massflow (kg/h)	Heat load (kW)	Water flow (kg/h)
EVC 1½" - 1F	30	19	804
EVC 2" - 1F	50	31	1350
EVC 3" - 1F	75	47	2020
EVC 3" - 1F	100	62	2690
EVC 4" - 1F	200	125	5370
EVC 6" - 1F	300	187	8060
EVC 8" - 1F	500	312	13400
EVC 10" - 1F	750	469	20100

* Performance sized with water from 50 to 70 °C.

** Sized with maximum inlet steam velocity 15 m/s.

Pressure / temperature limits

TMA	Maximum allowable temperature	Shell side	300 °C	
		Tube side	200 °C	
PMA	Maximum allowable pressure	Shell side	-10 °C to +200 °C	12 bar g
		Tube side	-10 °C to +200 °C	12 bar g

The cold hydraulic tests are performed at 18 bar g for both sides (shell and tube). This pressure meets with the requirements of Section 7.4, attachment 1, of the European Pressure Equipment Directive 97/23/EC.

Materials

No. Part	Material	ASTM designation
1 Shell	Stainless steel	A312 TP304
2 Expansion joint	Stainless steel	A240 TP321
3 Tubesheet	Stainless steel	A182 F316
4 Shell side connections	Stainless steel	A182 F304
5 Tubes (corrugated)	Stainless steel	A249 TP316

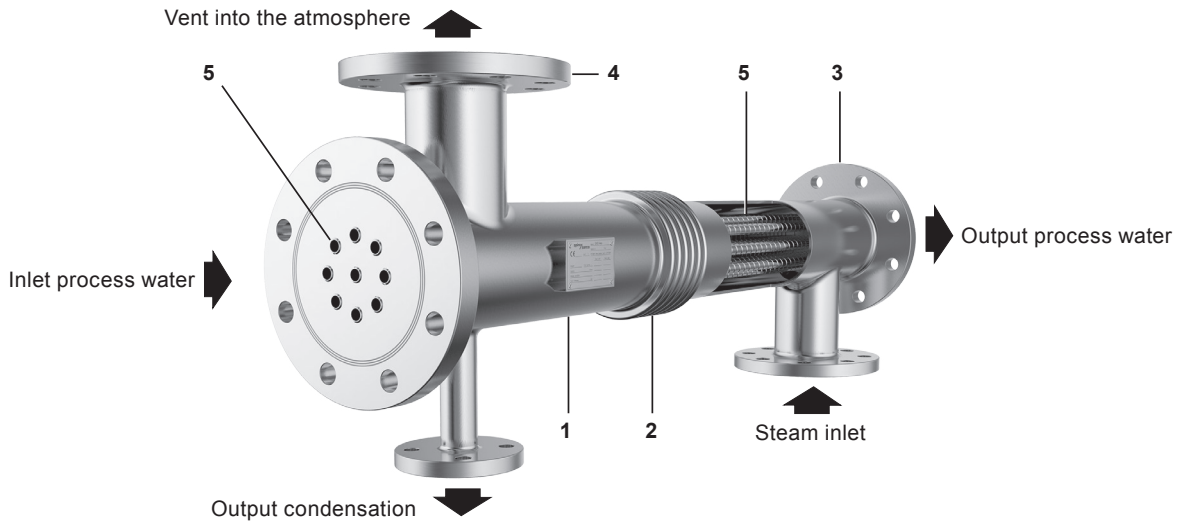

Dimensions / weights (approximate) in mm and kg

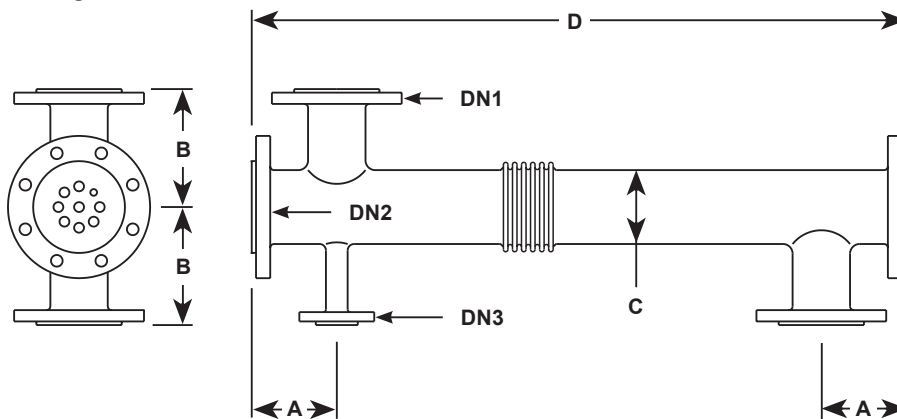

Model	DN1	DN2	DN3	A	B	C	D	Weight
EVC 1½" - 1F	32	40	15	94	140	48.5	1000	18
EVC 2" - 1F	40	50	15	90	140	60.3	1000	19
EVC 3" - 1F	65	80	15	110	160	88.9	1000	30
EVC 4" - 1F	80	100	25	125	180	114.3	1000	37
EVC 6" - 1F	100	150	25	140	220	168.3	1000	62
EVC 8" - 1F	125	200	32	160	250	219.1	1000	92
EVC 10" - 1F	150	250	40	180	280	273.0	1000	190

Tolerance according to UNI 6100 and TEMA:

D = ±3 mm

B = ±3 mm

Flange rotation = ±1°

Connection alignment = ±1.5 mm

Safety information, installation and maintenance

For full details see the Installation and Maintenance Instructions supplied with the product.

Installation note:

The installation depends on the application and on the service required; however **the unit must always be installed horizontally**. It is always necessary that one end of the heat exchanger is allowed to move axially, in order to permit the normal expansion of the exchangers tubes during operation.

We recommend that an air vent be fitted to the unit to continuously vent during start-up and operation.

Insulation is recommended, and it is absolutely necessary, if the shell temperature is much higher than the ambient one - If insulation is required it is suggested that it be fitted on site to eradicate its damage whilst in transit.

Disposal

This product is recyclable. No ecological hazard is anticipated with the disposal of this product providing due care is taken.

Typical installation

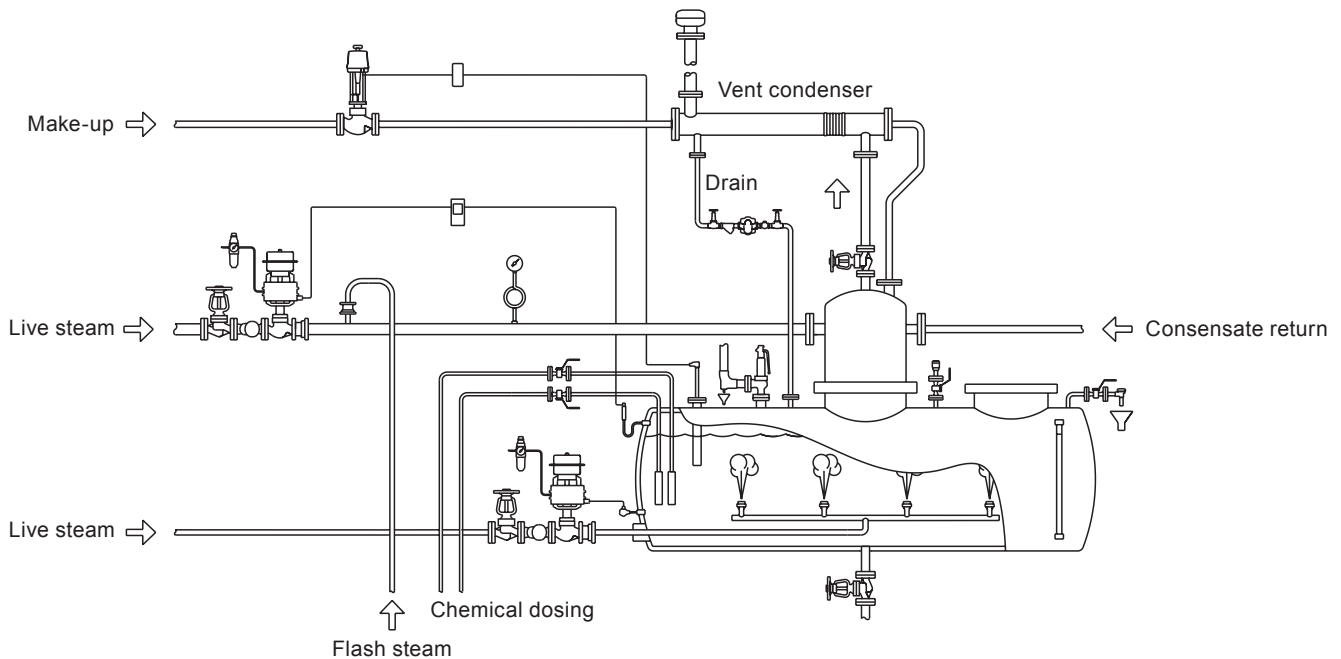

Sizing and selection

Spirax Sarco has developed integrated thermal modelling, sizing and selection software, to select and fully optimise an EVC heat exchanger to precisely match your application needs. Trained technicians are available at your local Spirax Sarco company to ensure the correct heat exchanger is always selected. Because of Spirax Sarco's expertise and wide product range we can provide a complete heat transfer solution, advising on the most suitable control system and ancillary equipment for your heat exchanger.

Our technicians can also advise on the suitability and sizing of heat exchangers for most gases, vapours and superheated liquids other than water.

EVC product nomenclature:

Please note that other units are available on request to suit the specifics of a particular process application.

Model	EVC = Exhaust Vapour Condenser	EVC
Shell diameter	1½", 2", 3", 4", 6", 8" and 10"	3"
Tube side material	SX = Stainless steel AISI 316	SX
EVC length	1 = 1 metre	1
Connection	F = Flanged	F
Design pressure shell side	V	V
Tube / tube sheet coupling	Empty = Expanding	
	Empty = SEP	
PED category	CI = Category I	CI
	CII = Category II	

Selection example EVC 3" SX 1 F V CI