

spirax sarco

TDC46M

TI-P187-04
CMGT Issue 6

Carbon Steel

Thermodynamic Steam Trap with Maintainable Seat

Description

The TDC46M is a carbon steel, thermodynamic steam trap that has been specifically designed for low capacity applications up to 46 bar g (where pipe connections permit). As standard the unit is available with either screwed, socket weld or flanged connections.

TDC46M benefits:

- Integral strainer.
- Integral air vent.
- Insulation cap.
- Replaceable seat for ease of maintenance.

Optional extras

At extra cost a **BDV1** integral blowdown valve can be pre-fitted to the strainer cap, please specify at the time of order placement.

Standards

This product fully complies with the requirements of the European Pressure Equipment Directive 97/23/EC.

Certification

These products are available with certification to EN 10204 3.1.

Note: All certification / inspection requirements must be specified at the time of order placement.

Materials

No.	Part	Material
1	Body	Carbon steel 1.0619+N/ASTM A216 WCB
2	Top cap	Stainless steel 1.4301/ASTM 479 304
3	Insulating cover	Stainless steel EN 10088-1 1.4301
4	Disc	Hardened steel 1.2379
5	Seat	Hardened steel 1.2379
6	Bimetal ring	Bimetal
7	Support	Stainless steel AISI 304
8	Seat gasket	Graphite foil
9	Strainer screen	Stainless steel ASTM A478 316L
10	Strainer cap gasket	Stainless steel AISI 304
11	Strainer cap	Stainless steel 1.4308/ASTM A351 CF8

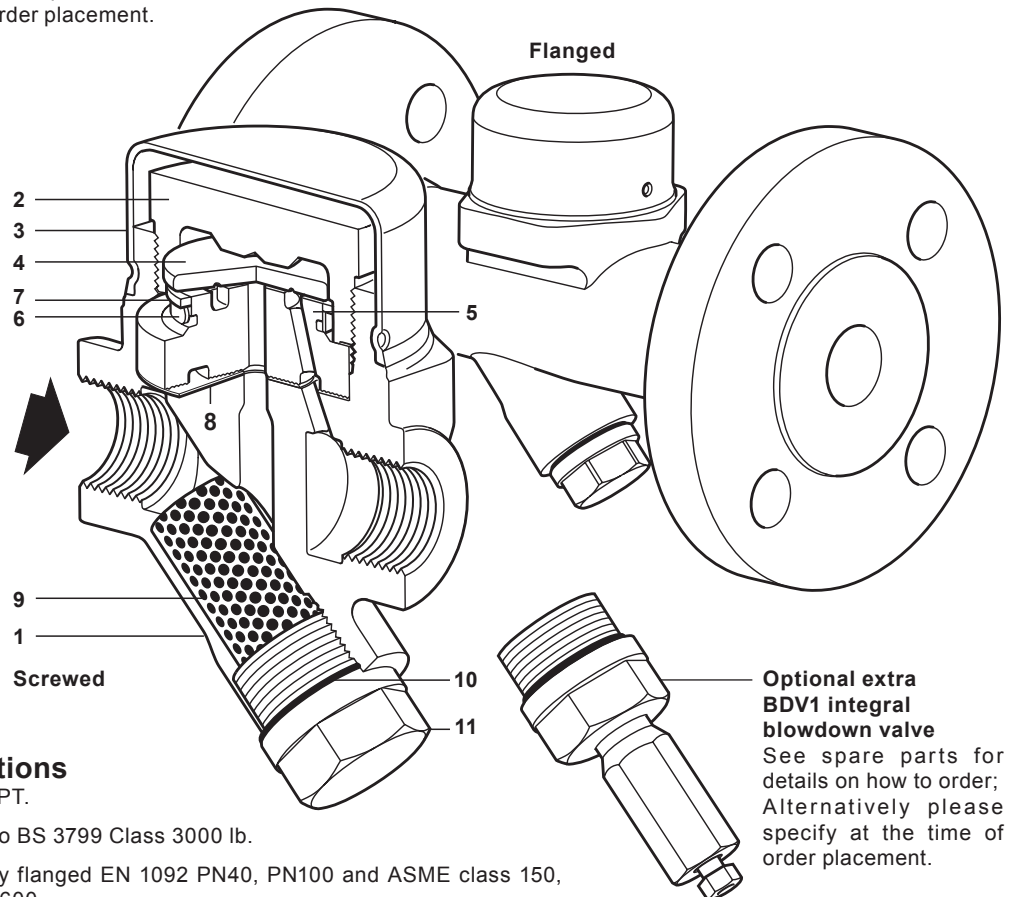

Sizes and pipe connections

½", ¾" and 1" screwed BSP or NPT.

½", ¾" and 1" socket weld ends to BS 3799 Class 3000 lb.

DN15, DN20 and DN25 integrally flanged EN 1092 PN40, PN100 and ASME class 150, ASME class 300 or ASME class 600.

Pressure / temperature limits (ISO 6552) - Screwed and Socket weld

**Screwed
Socket weld**

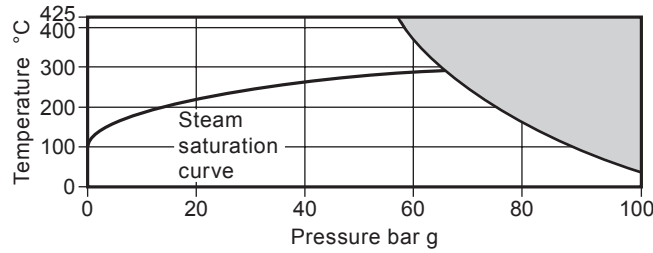

The product **must not** be used in this region or beyond the parameter of the PMA or TMA of the relative end connection.

	Body design condition	PN100 and ASME Class 600
	PMA Maximum allowable pressure	100 bar g @ 50 °C
	TMA Maximum allowable temperature	425 °C @ 57.5 bar g
	Minimum allowable temperature	-29 °C
Screwed Socket weld	PMO Maximum operating pressure	46 bar g @ 425 °C
	TMO Maximum operating temperature	425 °C @ 46 bar g
	Minimum operating temperature	0 °C
	Minimum operating pressure	1.5 bar g
	Maximum operating backpressure	80% of upstream pressure
	Designed for a maximum cold hydraulic test pressure of:	150 bar g

Pressure / temperature limits (ISO 6552) - Flanged EN 1092

**Flanged:
PN40
PN100**

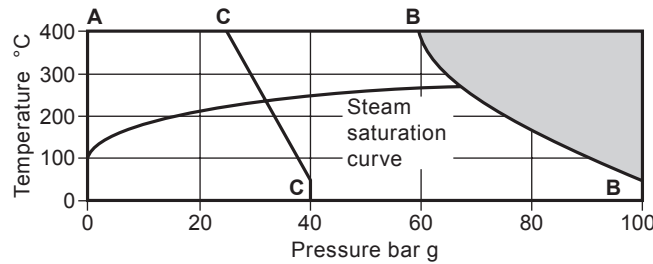

The product **must not** be used in this region or beyond the parameter of the PMA or TMA of the relative end connection.

A - B - B PN100	Body design condition	PN100
	PMA Maximum allowable pressure	100 bar g @ 50 °C
	TMA Maximum allowable temperature	400 °C @ 59.5 bar g
	Minimum allowable temperature	-10 °C
	PMO Maximum operating pressure	46 bar g @ 400 °C
	TMO Maximum operating temperature	400 °C @ 46 bar g
	Minimum operating temperature	0 °C
	Minimum operating pressure	1.5 bar g
	Maximum operating backpressure	80% of upstream pressure
	Designed for a maximum cold hydraulic test pressure of:	150 bar g
A - C - C PN40	Body design condition	PN40
	PMA Maximum allowable pressure	40 bar g @ 50 °C
	TMA Maximum allowable temperature	400 °C @ 23.8 bar g
	Minimum allowable temperature	-10 °C
	PMO Maximum operating pressure for saturated steam service	31.1 bar g @ 238 °C
	TMO Maximum operating temperature	400 °C @ 23.8 bar g
	Minimum operating temperature	0 °C
	Minimum operating pressure	1.5 bar g
	Maximum operating backpressure	80% of upstream pressure
	Designed for a maximum cold hydraulic test pressure of:	60 bar g

Pressure / temperature limits (ISO 6552) - Flanged ASME

Flanged:
ASME Class 150
ASME Class 300
ASME Class 600

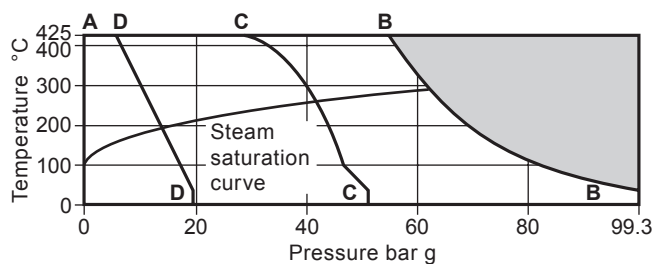

The product **must not** be used in this region or beyond the parameter of the PMA or TMA of the relative end connection.

A - B - B ASME 600	Body design condition	ASME Class 600
	PMA Maximum allowable pressure	99.3 bar g @ 38 °C
	TMA Maximum allowable temperature	425 °C @ 56 bar g
	Minimum allowable temperature	-29 °C
	PMO Maximum operating pressure	46 bar g
	TMO Maximum operating temperature	425 °C @ 46 bar g
	Minimum operating temperature	0 °C
	Minimum operating pressure	1.5 bar g
	Maximum operating backpressure	80% of upstream pressure
	Designed for a maximum cold hydraulic test pressure of:	149 bar g
A - C - C ASME 300	Body design condition	ASME Class 300
	PMA Maximum allowable pressure	51.1 bar g @ 38 °C
	TMA Maximum allowable temperature	425 °C @ 28.8 g
	Minimum allowable temperature	-29 °C
	PMO Maximum operating pressure for saturated steam service	43 bar g
	TMO Maximum operating temperature	425 °C @ 28.8 bar g
	Minimum operating temperature	0 °C
	Minimum operating pressure	1.5 bar g
	Maximum operating backpressure	80% of upstream pressure
Designed for a maximum cold hydraulic test pressure of:	76.6 bar g	
A - D - D ASME 150	Body design condition	ASME Class 150
	PMA Maximum allowable pressure	19.6 bar g @ 38 °C
	TMA Maximum allowable temperature	425 °C @ 5.5 bar g
	Minimum allowable temperature	-29 °C
	PMO Maximum operating pressure for saturated steam service	14 bar g
	TMO Maximum operating temperature	425 °C @ 5.5 bar g
	Minimum operating temperature	0 °C
	Minimum operating pressure	1.5 barg
	Maximum operating backpressure	80% of upstream pressure
Designed for a maximum cold hydraulic test pressure of:	29.4 bar g	

Dimensions (approximate) in mm

Size	A	Screwed	Socket weld	B		C	D	E	F
				Flanged	Flanged				
				PN40 ASME 150, 300, 600	PN100			Withdrawal distance	Withdrawal distance
½" DN15	58	78	92	150	210	61	59	40	30
¾" DN20	61	95	92	150	210	61	63	40	30
1" DN25	65	95	92	160	230	61	67	40	30

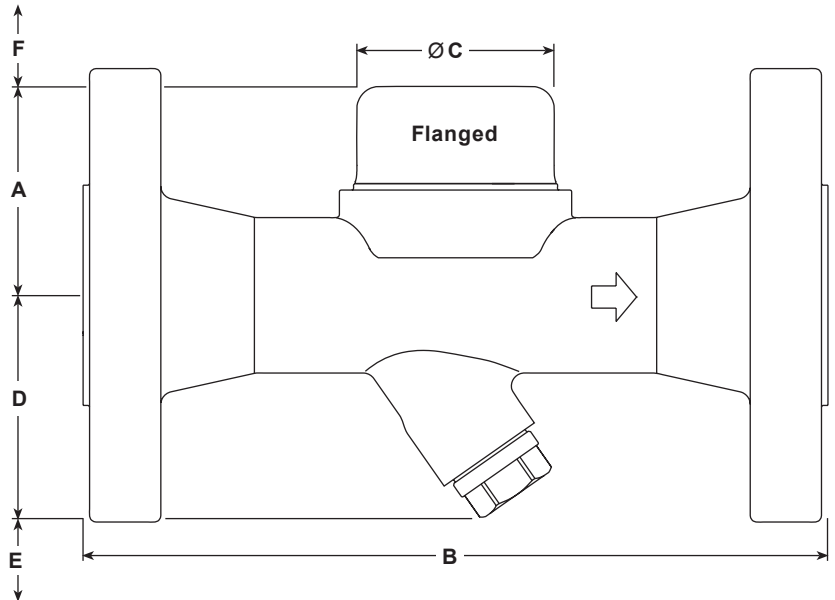
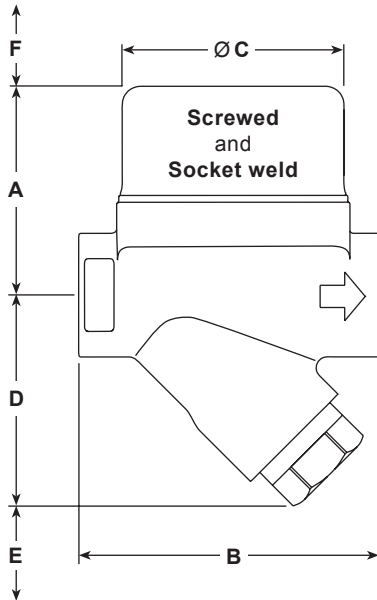

Weights (approximate) in kg

Size	Screwed	Socket weld	Flanged				
			ASME 150	ASME 300	ASME 600	PN40	PN100
½" DN15	1.38	1.49	2.46	2.96	3.06	3.06	4.36
¾" DN20	1.64	1.64	3.16	4.06	4.26	3.96	6.26
1" DN25	1.90	1.90	4.16	5.16	5.46	4.86	8.16

Capacities

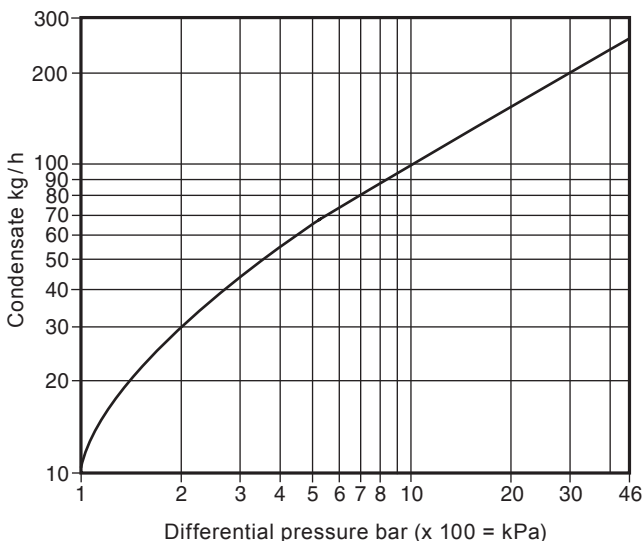

Safety information, installation and maintenance

For full details see the Installation and Maintenance Instructions (IM-P187-05) supplied with the product.

Installation note:

The TDC46M is designed for installation with the disc in a horizontal plane with the insulating cover at the top.

It is recommended that a non-return valve is fitted when discharging condensate into return lines where backpressure is experienced. It is also recommended that a diffuser is fitted when discharging to atmosphere.

For ease and maintenance, consideration should be given to fitting isolation valves upstream and downstream of the steam trap.

How to order

Example: 1 off Spirax Sarco DN15 TDC46M thermodynamic steam trap having flanged EN 1092 PN40 connections.

Spare parts

Please note that the spares shown are the same for the screwed, socket weld and flanged versions.

The spare parts available are shown in solid outline. Parts drawn in a grey line are not supplied as spares.

Available spares

Insulating cover	3
Top cap, seat and disc assembly	2, 4, 5, 6, 7, 8
Strainer screen and gasket	9, 10
Set of gaskets (packet of 3 sets)	8, 10
BDV1 blowdown valve retrofit kit	

How to order spares

Always order spares by using the description given in the column headed 'Available spares' and state the size and type of trap.

Example: 1 off Top cap, seat and disc assembly for a Spirax Sarco DN15 TDC46M thermodynamic steam trap.

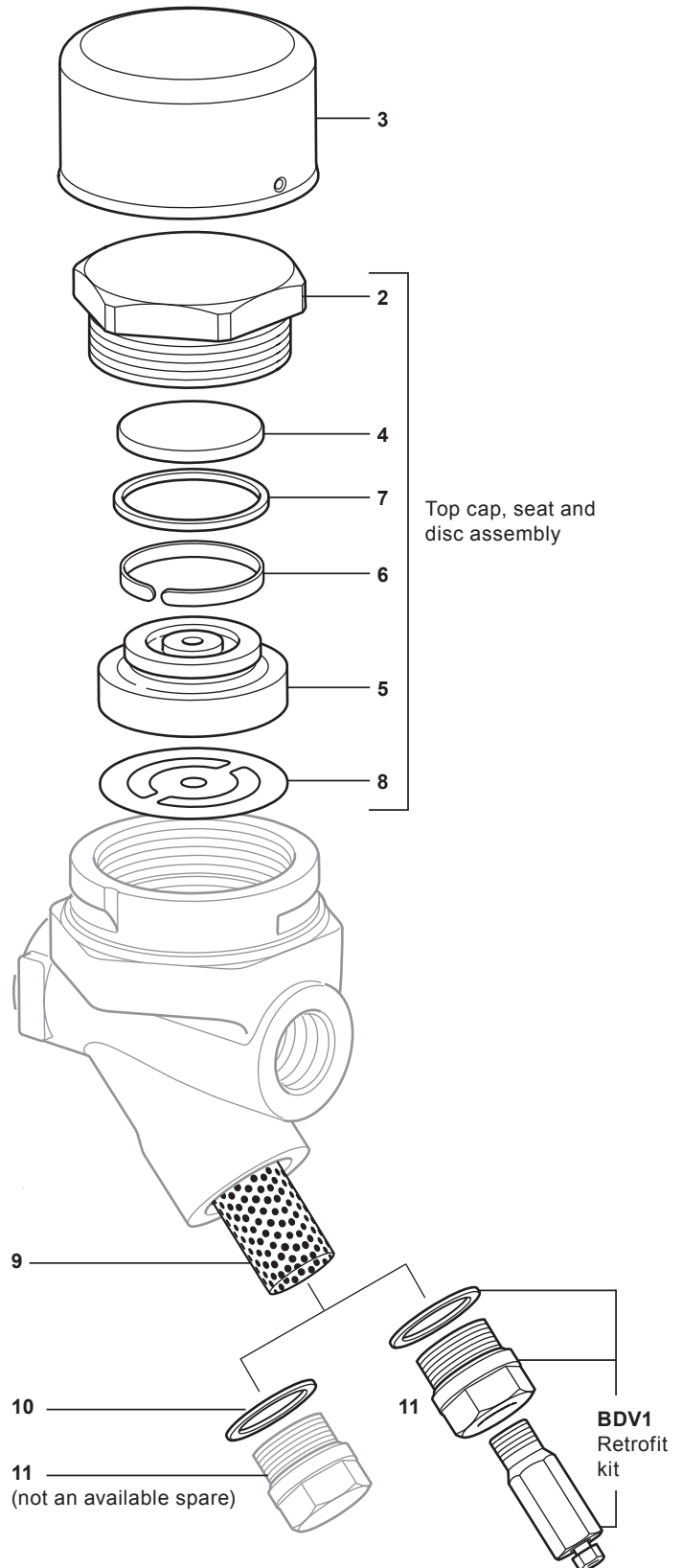

Recommended tightening torques - for suitably lubricated threads

Item	Part	 mm	N m
2	Top cap	50 A/F	300
11	Strainer cap	24 A/F	105 - 110