



TD42S2

Thermodynamic Steam Traps

Description

The TD42S2 is a thermodynamic steam trap with forged steel body and socket weld ends.
A full range of lower capacity traps (½" - 1") designated TD42S2LC are available for applications such as mains drainage or tracing.

Please note:

For low temperature applications down to -46 °C use the TD42S3 (ASTM A350 LF2) - See TI-P068-23 for further information.

Standards

This product fully complies with the requirements of the Pressure Equipment Directive (PED).

Certification

This product is available with certification to EN 10204 3.1.

Note: All certification/inspection requirements must be stated at the time of order placement.

Sizes and pipe connections

½"LC, ¾"LC, 1"LC, ½", ¾" and 1" socket weld ends to:
ASME (ANSI) B 16.11 Schedule 80 / BS 3799 Class 3000 lb.

Optional extras

Insulating cover: To prevent the trap being unduly influenced by excessive heat loss such as when subjected to low outside temperatures, wind, rain etc.

Integral blowdown valve: A BDV1 or BDV2 can be fitted to the strainer cap, alternatively the strainer cap can be drilled, tapped and plugged ⅜" BSP or NPT.

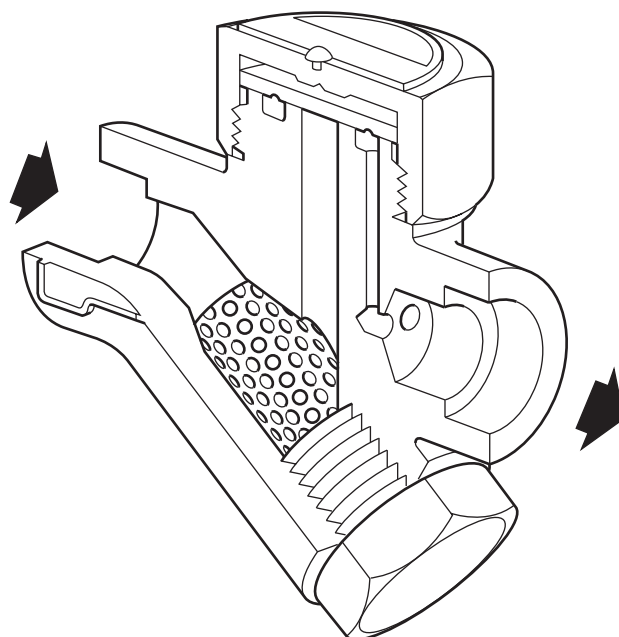



Pressure/temperature limits (ISO 6552)

Please note:

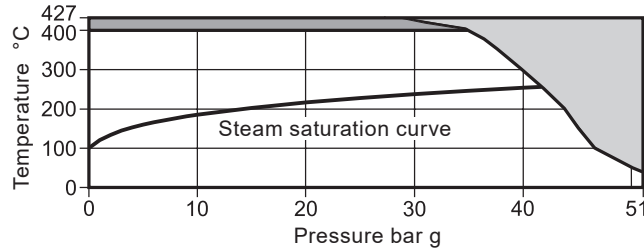
For low temperature applications down to -46 °C use the TD42S3 (ASTM A350 LF2) - See TI-P068-23 for further information.



 The product **must not** be used in this region.

 The product should not be used in this region.

Note: Upon prolonged exposure to temperatures above 425 °C, the carbide phase of steel may be converted to graphite. Permissible but not recommended for prolonged use above 425 °C.

Body design conditions	ANSI/ASME 300
PMA Maximum allowable pressure	51 bar g @ 38 °C
TMA Maximum allowable temperature	427 °C @ 28 bar g
Minimum allowable temperature	0 °C
PMO Maximum operating pressure for saturated steam service	42 bar g
TMO Maximum operating temperature	400 °C @ 34 bar g
Minimum operating temperature	0 °C
Note: For lower operating temperatures consult Spirax Sarco	
ΔPMX Maximum differential pressure	42 bar
PMOB Maximum operating backpressure should not exceed 80% of the inlet pressure.	
Minimum inlet pressure for satisfactory operation	0.25 bar g
Designed for a maximum cold hydraulic test pressure of:	76 bar g

Materials

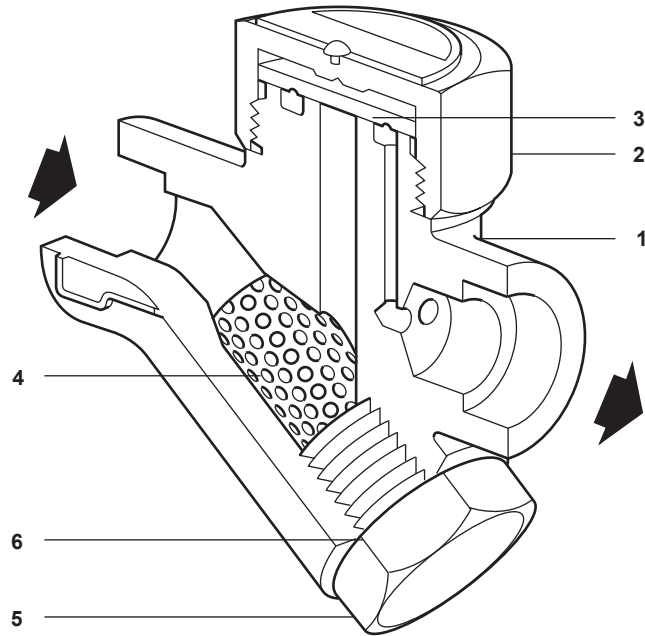

No.	Part	Material	
1	Body	Steel	ASTM A105N
2	Cap	Stainless steel	AISI 416
3	Disc	Stainless steel	BS 1449 420 S45
4	Strainer screen	Stainless steel	AISI 316L
5	Strainer cap	Steel	ASTM A105N
6	Strainer cap gasket	Stainless steel	BS 1449 304 S16
7*	Insulating cover (optional extra)	Aluminium	

* **Note:** Item 7 is shown on the spares illustration overleaf.

Capacities

When sizing the TD42S2 it is important to ensure that the correct model is selected. This will ensure the required operation and maximum life. For mains drainage and tracing applications the LC version should be selected irrespective of pipe size.

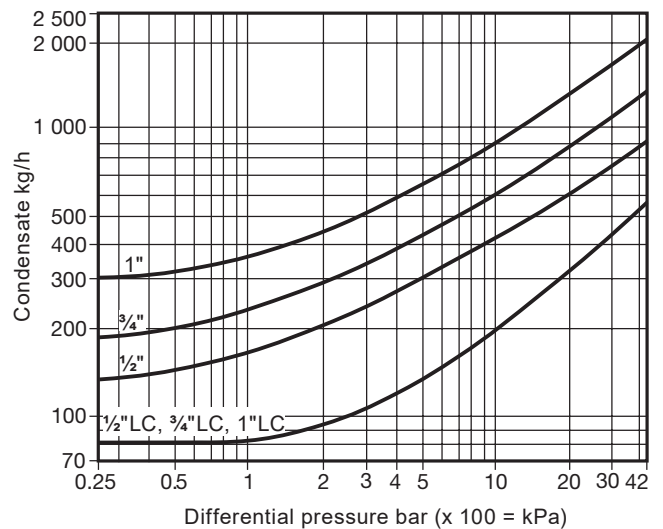

Dimensions/weights (approximate) in mm and kg

Size	A	B	C	D	E	F	G	H	Weight
½"	41	76	46	71	20	57	57	38	0.80
½" LC	40	76	46	71	20	57	57	38	0.75
¾"	47	78	47	72	20	63	57	38	1.00
¾" LC	44	78	47	72	20	57	57	38	1.00
1"	53	92	52	77	25	63	70	38	1.50
1" LC	48	92	52	77	20	60	57	38	1.50

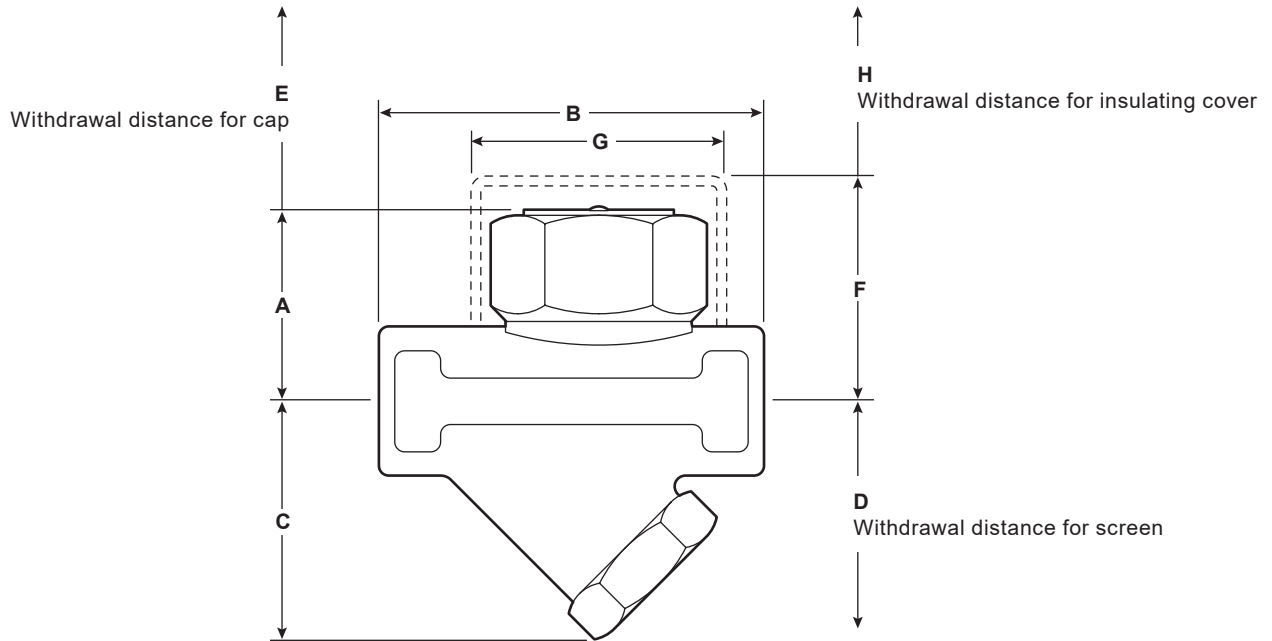

Safety information, installation and maintenance

For full details see the Installation and Maintenance Instructions (IM-P068-37) supplied with the product.

Installation note

The TD42S2 should be installed preferably in the horizontal position. However it can also be installed and operate in other orientations.

Disposal

This product is recyclable. No ecological hazard is anticipated with the disposal of this product providing due care is taken.

How to order

Example: 1 off Spirax Sarco ½" TD42S2LC thermodynamic steam trap fitted with an insulating cover for outside weather protection and having socket weld end connections.

Spare parts

The spare parts available are shown in solid outline. Parts drawn in a grey line are not supplied as spares.

Available spares

Disc	(packet of 3)	3
Strainer screen and gasket		4, 6
Strainer cap gasket	(packet of 3)	6
Insulating cover		7



How to order spares

Always order spares by using the description given in the column headed 'Available spares' and state the size and type of trap.

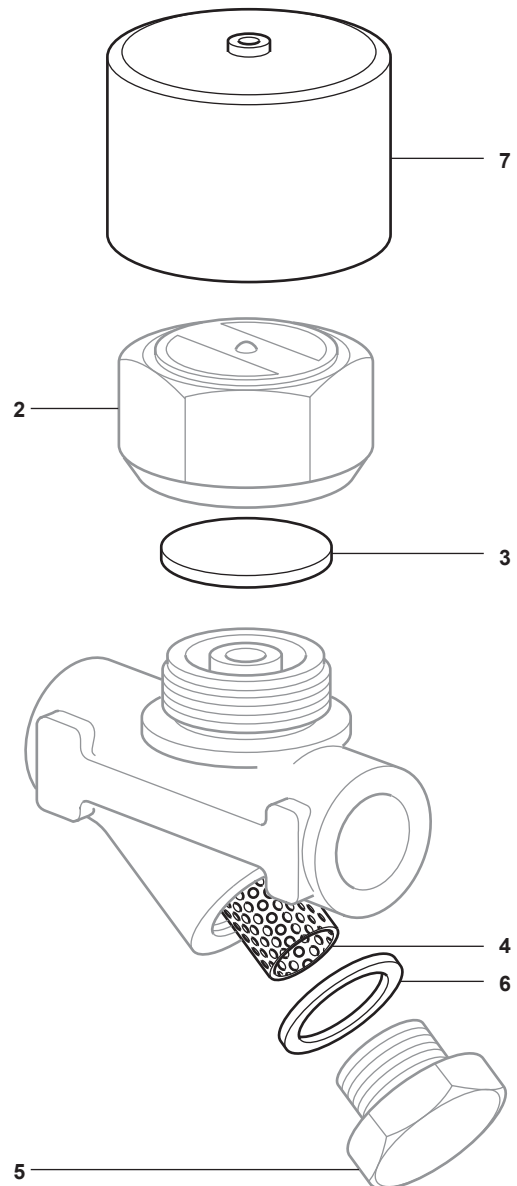
Example: 1 off Strainer screen and gasket for a Spirax Sarco ½" TD42S2 thermodynamic steam trap.



Recommended tightening torques

Item	Part	 or mm		N m
2	½" LC	36 A/F		87 - 97
	¾" LC	36 A/F		87 - 97
	1" LC	36 A/F		87 - 97
	½"	41 A/F		100 - 110
	¾"	41 A/F		100 - 110
	1"	55 A/F		140 - 160
5	(all sizes)	27 A/F	M24	120 - 135