

SV615 Safety Valve

Description

The SV615 full lift, full nozzle safety valve is suitable for steam, air, inert industrial gas and non-hazardous liquid service.

Applications

The SV615 is suitable for the protection of steam or hot water boilers, generators, vessels, receivers and air compressors, autoclaves, downstream of pressure reducing valves and for general pressure relief applications.

Available types

Valves are available in sizes ranging from DN15 to DN50 and have a bronze body with female screwed connections and a stainless steel nozzle. There is also the option of a 1" sanitary clamp inlet connection on the smaller sizes. All valves have a closed bonnet with either a lifting lever or closed cap (gas tight cap option). An optional soft seal is available in Nitrile, EPDM or Viton. Where frequent washdown occurs or aesthetic appearance is a consideration, this product can also be supplied with an electroless nickel plated (ELNP) finish to the body, lever housing (or sealed cap) and lever. A mechanically fastened stainless steel name-plate can also be provided - For full details contact Spirax Sarco.

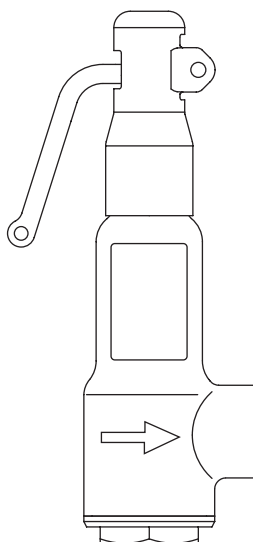

Screwed female version

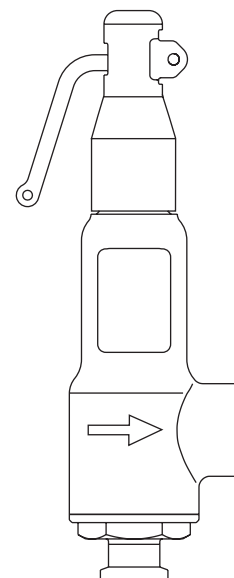

1" Sanitary clamp version

Standards and approvals

The SV615 complies with the requirements of EN ISO 4126:2004 and carries the  mark indicating full compliance with the requirements of the European Pressure Equipment Directive 2014/68/EU.

Seat tightness complies with ASME/API STD 527- Revision 2002.

Certification

A manufacturers' Typical Test Report is provided as standard for each valve which will include valve set and hydraulic test pressure. Also available on request is material certification in accordance with EN 10204 3.1.

Sizes and end connections

DN15, DN20, DN25, DN32, DN40 and DN50.

Inlet connections

Screwed BSP T Rp (ISO 7-1) or NPT female connections.

1" Sanitary clamp compatible (DN15, DN20 and DN25 sizes only)

BS 4825/ISO 2852/DIN 32676 - Safety valves with these connections have a surface finish of 0.8 µm on primary wetted parts.

Outlet connections

Screwed BSP (BS 21 parallel) or NPT female connection.

Pressure/temperature limits

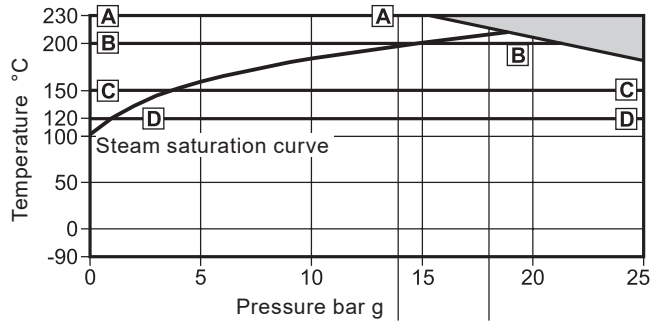

Maximum set pressure for 1½" and 2" SV615

Maximum set pressure for ½" to 1¼" SV615

The product **must not** be used in this region.

- A - A** Maximum operating temperature with metal seat.
- B - B** Maximum operating temperature with Viton seat.
- C - C** Maximum operating temperature with EPDM seat.
- D - D** Maximum operating temperature with Nitrile seat.

Body design conditions		PN25	
Set pressure range	Maximum	½" to 1¼"	18 bar g
		1½" and 2"	14 bar g
	Minimum		0.3 bar g
Temperature	Metal seat	Minimum	-90 °C
		Maximum	+230 °C
	* Nitrile seat	Minimum	-30 °C
		Maximum	+120 °C
	* EPDM seat	Minimum	-50 °C
		Maximum	+150 °C
* Viton seat	Minimum	-20 °C	
	Maximum	+200 °C	
Performance data	Overpressure	Steam	5%
		Gas	10%
		Liquid	10%
	Blowdown limits	Steam, gas	10%
		Liquids	20%
	Derated coefficient of discharge values	Steam, gas	0.71
		Liquid	0.52
Maximum permitted backpressure			10% of set pressure
Tested at a maximum inlet cold hydraulic test pressure of:			37.5 bar g

* **Note:** Soft seal inserts are not suitable for steam applications.

Materials

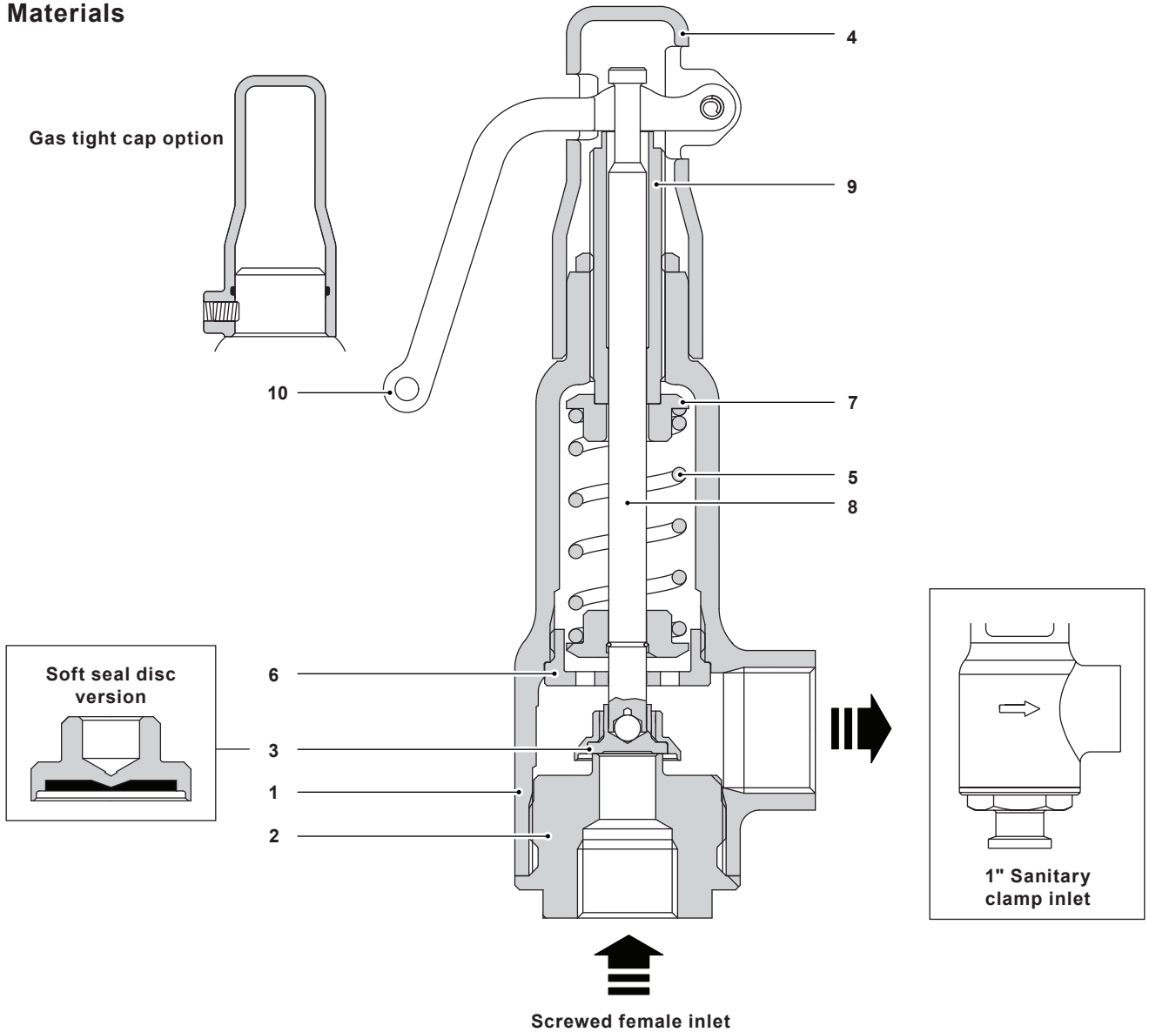

No.	Part	Material	
1	Body	Bronze	BS EN 1982 CC491KM
		DN15 and DN20 Stainless steel	BS 970 431 S29
2	Nozzle	DN25 to DN50 Stainless steel	BS 3146 Pt2 Gr. ANC2
		Sanitary connections Stainless steel	ASTM A276 316L
3	Disc	Stainless steel	ASTM A276 316L
4	Lever housing	Bronze	BS EN 1982 CC491KM
5	Spring	Chrome-vanadium alloy steel	BS 2803 735 A50 HS
6	Stem guide	Brass	BS 2872 CZ 121
7	Spring end plate	Brass	BS EN 12165 - CW617N
8	Stem	Stainless steel	BS 970 431 S29
9	Adjustment screw	Brass	BS 2874 CZ 121
10	Lever	SG iron	Zinc plated

Materials continued on the next page

Materials (continued)

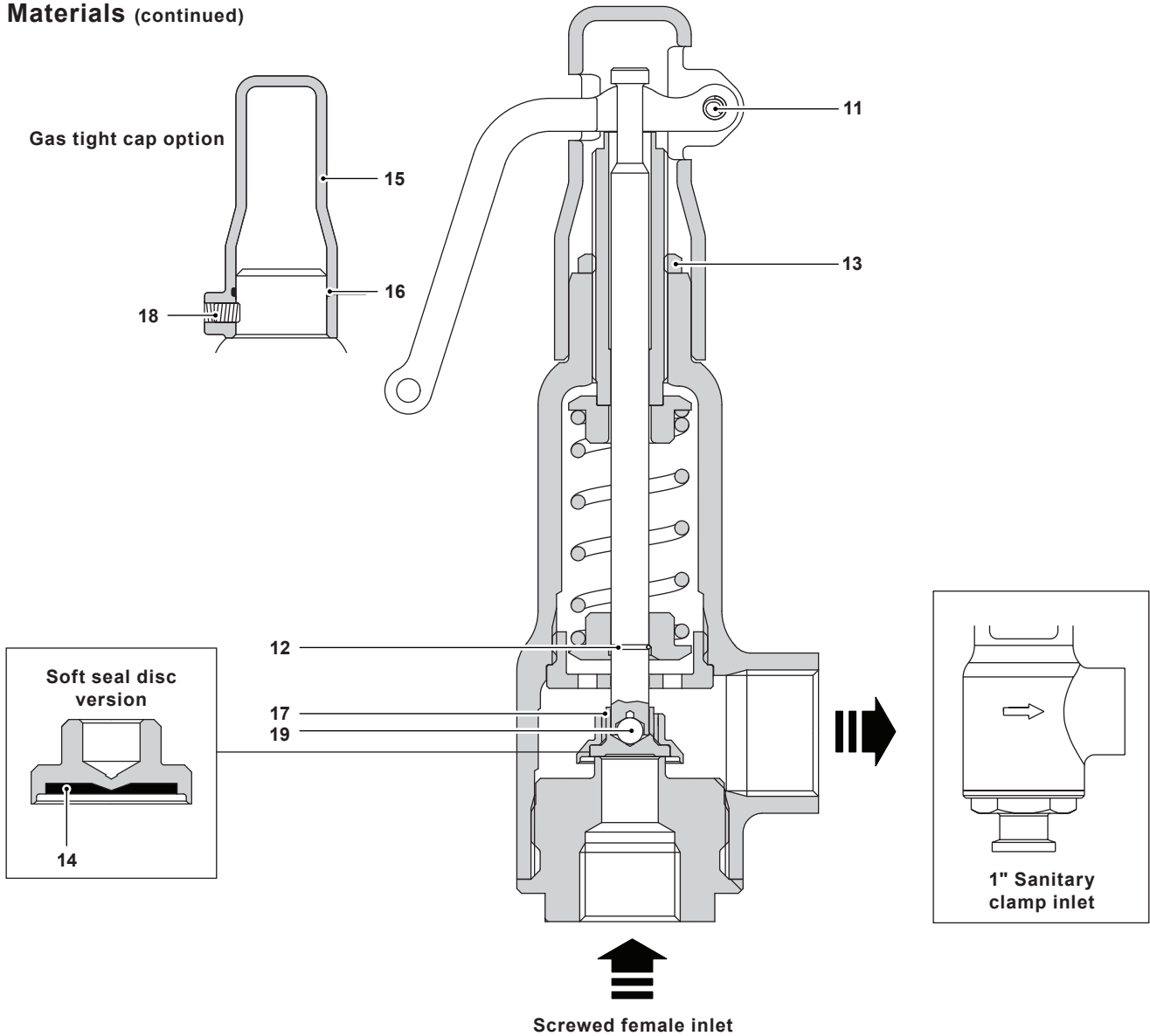

No.	Part	Material	
11	Pivot pin	Stainless steel	AISI 304
12	Circlip	Stainless steel	BS 2056 316 S42
13	Adjuster lock-nut	Brass	BS 2872 CZ 121
14	Soft seal disc	Stainless steel/Nitrile insert	ASTM A276 316/bonded Nitrile 4490 (90 IRHD)
		Stainless steel/EPDM insert	ASTM A276 316/bonded EPDM 2064 (75 IRHD)
		Stainless steel/Viton insert	ASTM A276 316/bonded Viton F81 (85 IRHD)
15	Sealed cap	Bronze	BS EN 1982 CC491KM
16	Cap seal	Nitrile	
17	Skirt	Brass	BS 2874 CZ 121
18	Grub screw	Steel	
19	Ball	Stainless steel	

Table 1 - SV615 flow capacity for saturated steam in kilogrammes per hour (kg/h)

(calculated in accordance with EN ISO 4126:2004 at 5% overpressure)

Derated coefficient of discharge (Kdr) = 0.71

Valve size DN in/out	15/20	20/32	25/40	32/50	40/65	50/80
Flow area (mm ²)	113	314	452	661	1 075	1 662
Set pressure (bar g)	Flow capacity for dry saturated steam kg/h					
0.5	68	188	271	396	644	996
1.0	90	250	360	527	857	1324
1.5	112	312	449	656	1067	1650
2.0	134	373	537	785	1276	1973
2.5	156	434	624	913	1485	2295
3.0	178	494	712	1040	1692	2616
3.5	200	555	799	1168	1899	2936
4.0	221	615	885	1295	2106	3256
4.5	243	675	972	1422	2312	3574
5.0	265	735	1058	1548	2517	3892
5.5	286	795	1144	1674	2722	4208
6.0	308	855	1230	1799	2926	4524
6.5	329	914	1316	1925	3130	4839
7.0	350	974	1402	2050	3334	5154
7.5	372	1033	1487	2175	3537	5468
8.0	393	1092	1573	2300	3740	5783
8.5	414	1152	1658	2425	3943	6096
9.0	436	1211	1743	2549	4146	6410
9.5	457	1270	1828	2674	4348	6723
10.0	478	1329	1913	2798	4551	7036
11.0	521	1447	2084	3047	4955	7661
12.0	563	1565	2253	3295	5359	8286
13.0	606	1683	2423	3544	5763	8910
14.0	648	1801	2593	3792		
15.0	691	1919	2762	4040		
16.0	733	2037	2932	4288		
17.0	775	2155	3101	4535		
18.0	818	2272	3271	4783		

Table 2 - SV615 flow capacity for air in litres per second (normal l/s) at 0 °C and 1.013 bar a
 (calculated in accordance with EN ISO 4126:2004 at 10% overpressure)
 Derated coefficient of discharge (Kdr) = 0.71

Valve size DN in/out	15/20	20/32	25/40	32/50	40/65	50/80
Flow area (mm²)	113	314	452	661	1 075	1 662

Set pressure (bar g)	Flow capacity for air l/s					
0.5	24	67	97	142	230	356
1.0	33	91	131	191	311	481
1.5	41	115	165	241	392	606
2.0	50	138	199	291	473	732
3.0	67	186	267	391	635	982
4.0	84	233	335	490	797	1 233
5.0	101	280	403	590	959	1 483
6.0	118	328	472	690	1 121	1 734
7.0	135	375	540	789	1 283	1 984
8.0	152	422	608	889	1 446	2 235
9.0	169	470	676	988	1 608	2 485
10.0	186	517	744	1 088	1 770	2 736
11.0	203	564	812	1 188	1 932	2 986
12.0	220	612	880	1 287	2 094	3 237
13.0	237	659	948	1 387	2 256	3 487
14.0	254	706	1 017	1 487	2 418	3 738
16.0	288	801	1 153	1 686		
18.0	322	896	1 289	1 885		

Table 3 - SV615 flow capacity for water in kilogrammes per hour (kg/h) at 20 °C

(calculated in accordance with EN ISO 4126:2004 at 10% overpressure)

Derated coefficient of discharge (Kdr) = 0.52

Valve size DN in/out	15/20	20/32	25/40	32/50	40/65	50/80
Flow area (mm ²)	113	314	452	661	1 075	1 662

Set pressure (bar g)	Flow capacity for water kg/h					
0.5	2 216	6 159	8 866	12 965	21 086	32 599
1.0	3 135	8 710	12 538	18 335	29 819	46 102
1.5	3 839	10 668	15 356	22 456	36 521	56 463
2.0	4 433	12 318	17 731	25 930	42 171	65 198
3.0	5 429	15 086	21 717	31 758	51 649	79 851
4.0	6 269	17 420	25 076	36 671	59 639	92 204
5.0	7 009	19 476	28 036	40 999	66 678	103 088
6.0	7 678	21 335	30 712	44 913	73 042	112 927
7.0	8 293	23 045	33 173	48 511	78 895	121 975
8.0	8 866	24 636	35 463	51 861	84 342	130 397
9.0	9 404	26 130	37 614	55 006	89 458	138 307
10.0	9 912	27 544	39 649	57 982	94 297	145 788
11.0	10 396	28 888	41 584	60 812	98 900	152 904
12.0	10 858	30 172	43 433	63 516	103 298	159 703
13.0	11 302	31 405	45 207	66 110	107 515	166 224
14.0	11 728	32 590	46 913	68 605	111 574	172 499
16.0	12 538	34 840	50 152	73 342		
18.0	13 299	36 954	53 194	77 791		

Table 4 - SV615 flow capacities for hot water in kilowatts (kW) at or above 100 °C

(calculated in accordance with EN ISO 4126:2004)

Derated coefficient of discharge (Kdr) = 0.52

Valve size DN in/out	15/20	20/32	25/40	32/50	40/65	50/80
Flow area (mm ²)	113	314	452	661	1 075	1 662

Set pressure (bar g)	Flow capacity for hot water kW					
0.5	29.96	83.26	119.86	175.27	285.06	440.71
1.0	40.60	112.81	162.39	237.47	386.21	597.09
1.5	51.23	142.36	204.92	299.66	487.36	753.47
2.0	61.86	171.96	247.45	361.86	588.51	909.86
3.0	83.13	230.99	332.51	486.24	790.81	1 222.62
4.0	104.39	290.08	417.57	610.63	993.11	1 535.38
5.0	125.66	349.17	502.63	735.02	1 195.42	1 848.15
6.0	146.92	408.26	587.69	859.41	1 397.72	2 160.91
7.0	168.19	467.36	672.75	983.80	1 600.12	2 473.67
8.0	189.45	526.45	757.81	1 108.18	1 802.32	2 786.43
9.0	210.72	585.54	842.88	1 232.57	2 004.62	3 099.20
10.0	231.98	644.63	927.94	1 356.96	2 206.92	3 411.96
11.0	253.25	703.72	1 013.00	1 481.35	2 409.22	3 724.72
12.0	274.51	762.81	1 098.06	1 605.74	2 611.52	4 037.49
13.0	295.78	821.90	1 183.12	1 730.12	2 813.82	4 350.25
14.0	317.04	880.99	1 268.18	1 854.51	3 016.12	4 663.01
16.0	359.58	999.17	1 438.30	2 103.29		
18.0	402.11	1 117.36	1 608.42	2 352.06		

Sizing and selection

Refer to:- <http://www.spiraxsarco.com/prs/product-sizing.asp>

Dimensions/weights (approximate) in mm and kg

	Connection			Flow					Weight
	Size	Inlet	Outlet	A	B	C*	E Ø	D Ø	
Screwed BSPF x BSPF or NPTF x NPTF	DN15	½"	¾"	40	40	194	-	12	1.3
	DN20	¾"	1¼"	55	44	229	-	20	2.4
	DN25	1"	1½"	60	48	242	-	24	2.9
	DN32	1¼"	2"	70	58	279	-	29	4.2
	DN40	1½"	2½"	81	67	365	-	37	8.8
	DN50	2"	3"	96	80	420	-	46	13.0
Sanitary clamp	DN15	1"	¾"	40	55	209	50.5	12	1.4
	DN20	1"	1¼"	55	60	245	50.5	20	2.6
	DN25	1"	1½"	60	64	258	50.5	24	3.1

* Applies to sealed cap and lever designs.

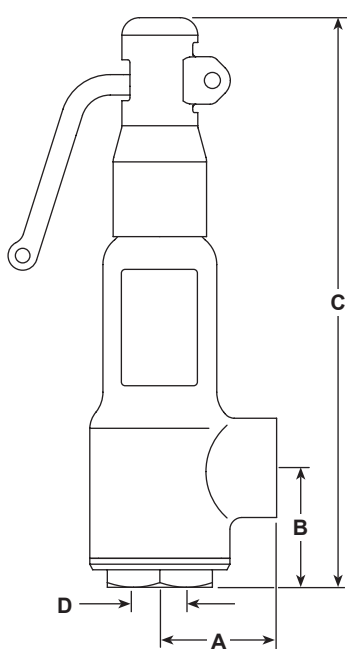

Screwed version

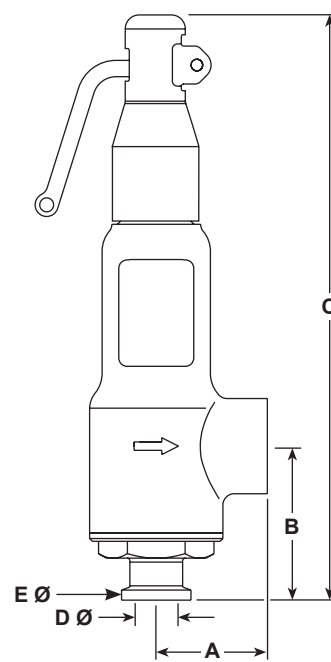

Sanitary clamp version

Safety information, installation and maintenance

For full details see the Installation and Maintenance Instructions (IM-P316-03) supplied with the product.

Installation note:

The safety valve should always be fitted with the centre line of the spring housing vertically above the valve. Ensure the discharge pipework system is sized correctly.

SV615 safety valve selection guide:

Model type	SV615	SV615
Configuration	A = Closed bonnet/easing lever	A
	B = Closed bonnet/sealed cap	
Seal material	S = Stainless steel	N
	N = Nitrile	
	E = EPDM	
	V = Viton	
Finish	P = Electroless nickel plated (ELNP)	
	Q = ELNP and stainless steel name-plate	
Size	DN15, DN20, DN25, DN32, DN40 and DN50	DN15
Connections (Inlet x Outlet)	BSPF x BSPF NPTF x NPTF Clamp x BSPF	BSPF x BSPF

Selection example

SV615	A	N		DN15	BSPF x BSPF
--------------	----------	----------	--	-------------	--------------------

If ELNP finish is required, add 'P'.

How to order example:

1 off Spirax Sarco SV615AN safety valve having DN15 screwed BSPF x BSPF connections, set at 6 bar g.