



Cert. No. LRQ 0963008

ISO 9001

# spirax sarco

**TI-P186-05**  
CH Issue 7

**SRV2S**

## Stainless Steel Pressure Reducing Valve

### Description

The SRV2S is a compact, stainless steel, direct acting pressure reducing valve designed for applications using steam or gases such as compressed air. All wetted parts are constructed in 316L stainless steel.

SRV2S pressure reducing valves are supplied with one of three colour coded springs which are identified by the disc (18) located on the adjustment handwheel (2):

**Grey** For downstream pressure control: 0.14 to 1.7 bar g

**Green** For downstream pressure control: 1.40 to 4.0 bar g

**Orange** For downstream pressure control: 3.50 to 8.6 bar g

**Note:** Where control spring ranges overlap always use the lower range to give better control.

### Standards

This product fully complies with the requirements of the European Pressure Equipment Directive 97/23/EC

### Certification

This product is available with certification to EN 10204 3.1.

**Note:** All certification/inspection requirements must be stated at the time of order placement.

### Sizes and pipe connections

½", ¾" and 1" screwed BSP (BS 21 Rp) or NPT.

DN15, DN20 and DN25 Flanged EN 1092 PN25 and ANSI 150.

### Pressure/temperature limits

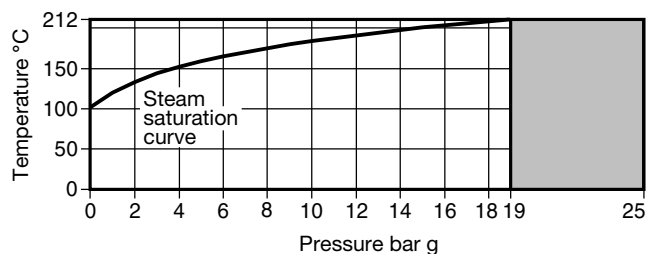

The product **must not** be used in this region.

Body design conditions	PN25
Maximum design pressure	25 bar g @ 120°C
Maximum design temperature	212°C @ 19 bar g
Minimum allowable temperature	0°C
Maximum operating pressure for saturated steam service	19 bar g
Maximum operating temperature	212°C @ 19 bar g
Minimum operating temperature	0°C

**Note:** For lower operating temperatures consult Spirax Sarco

Maximum downstream reduced pressure 8.6 bar g

Maximum differential pressure 19 bar

Maximum recommended turndown ratio 10:1 at maximum flow

Designed for a maximum cold hydraulic test pressure of 38 bar g

**Note:** With internals fitted, test pressure must not exceed 19 bar g

### Materials

No. Part	Material
1 Spring housing	Aluminium LM6 Electroless nickel finish
2 Adjustment handwheel	Plastic Polypropylene
3 Top spring plate	Cast iron DIN 1691 GG 20 Electroless nickel finish

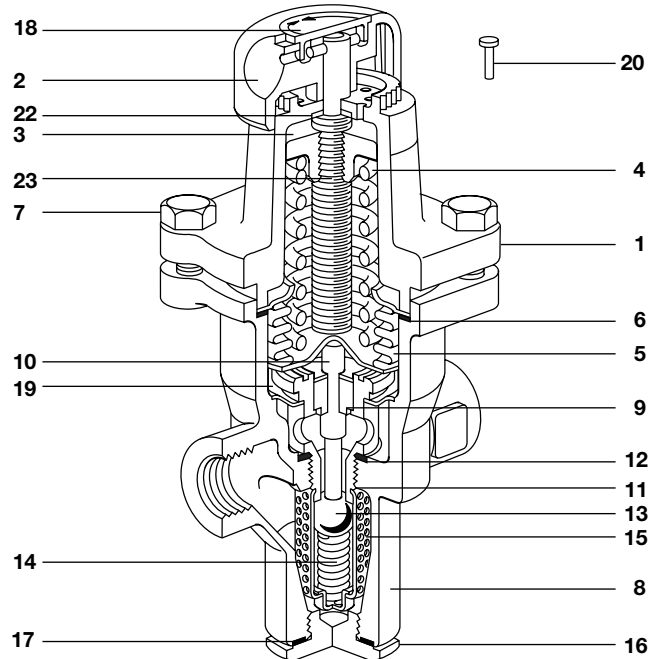

No. Part	Material
4 Pressure adjustment spring	Silicon chrome spring steel BS 2803 685 A55 Range 2 Electroless nickel finish
5 Bellows assembly	Stainless steel 316Ti / 316L
6 Bellows assembly gasket	Reinforced exfoliated graphite
7 Hex. bolt (M8 x 25 mm)	Stainless steel BS 6105 A 270
8 Body	Stainless steel BS 3100 316 C12 ASTM A351 CF 3M External electropolish finish
9 Guide bush	Graphite filled PTFE
10 Pushrod	Stainless steel ASTM A276 316L
11 Valve seat	Stainless steel BS 3100 316 C 12 ASTM A351 CF 3M DIN 1.4404
12 Valve seat gasket	Stainless steel BS 1449 316 S11
13 Valve	Stainless steel 316L
14 Valve return spring	Stainless steel BS 2056 316 S42
15 Strainer screen	Stainless steel BS 1449 316 SH
16 Bottom cap	Stainless steel ASTM A276 316L
17 Bottom 'O' ring	PTFE
18 Spring range identity disc	Plastic Polypropylene
19 Bulkhead plate	Stainless steel BS 1449 316 S13 AISI 316L
20 Tamper-proof pin	Mild steel copper plated
21 Flanges (not shown)	Stainless steel BS 3100 316 C12 ASTM A351 CF 3M Electropolish finish
22 Washer	Stainless steel 316L
23 Drive spindle	Carbon steel BS 970 230 M07 Electroless nickel finish

**Note:** Items 9, 10, 11, 13, 14 and 15 are all part of one assembly.

Local regulations may restrict the use of this product to below the conditions quoted.

In the interests of development and improvement of the product, we reserve the right to change the specification without notice.

© Copyright 2008

### Capacities for safety valve sizing

Full lift capacities for safety valve sizing purposes :	Size Kvs	DN15 1.5	DN20 2.5	DN25 3.0
---	-------------	-------------	-------------	-------------

For conversions:  $C_V (UK) = K_V \times 0.963$      $C_V (US) = K_V \times 1.156$

### Steam and compressed air capacities

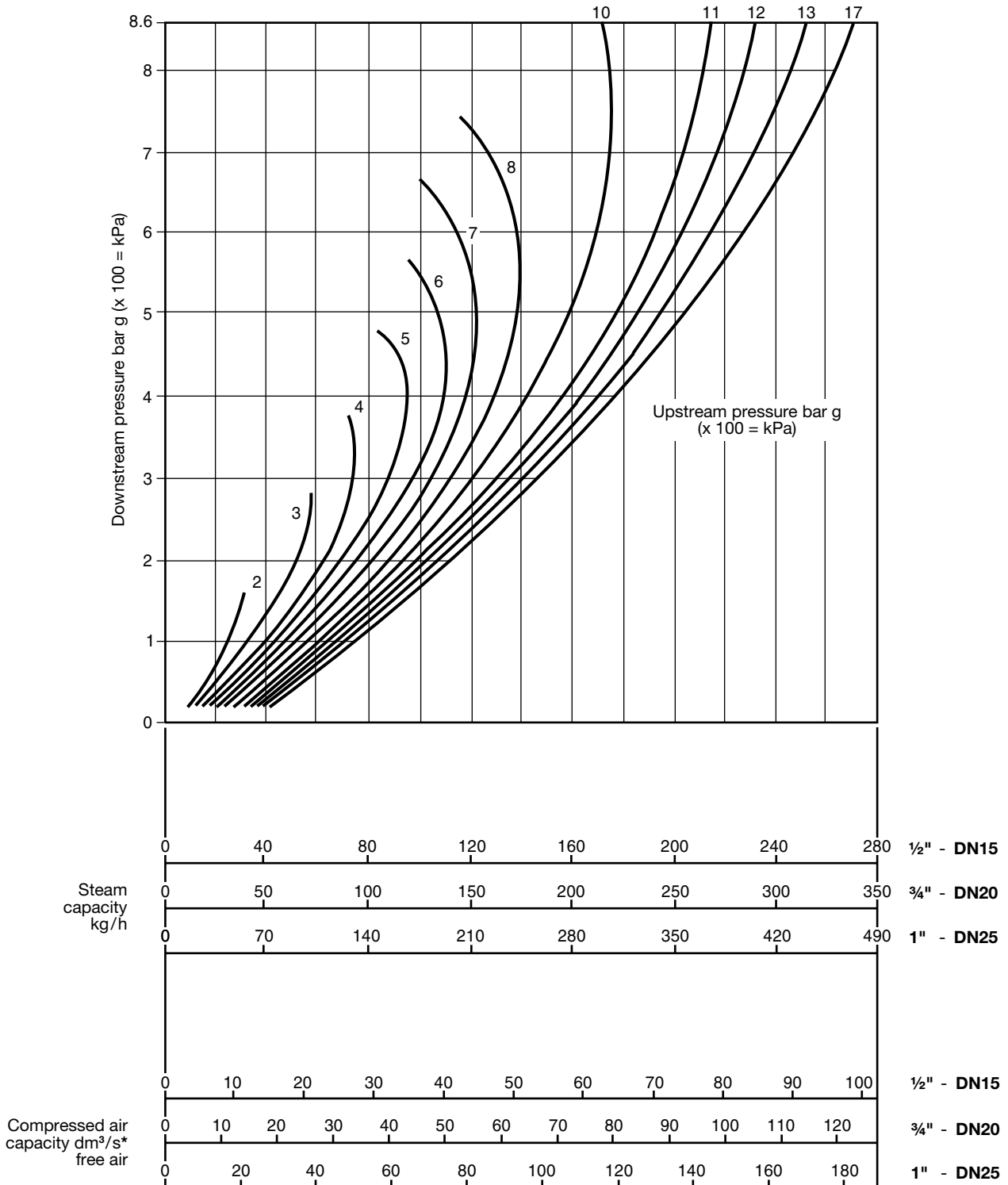

\*  $dm^3/s = l/s$ ,  $1 l/s \approx 2 c.f.m.$

### How to use the chart

The curved lines labelled 2, 3, 4, 5 etc., represent upstream pressures. Downstream pressures are read along the vertical line on the left hand side of the chart.

#### How to use the chart is best described by an example:-

Required, a pressure reducing valve to pass 120 kg/h reducing from 8 to 6 bar. From the downstream pressure of 6 bar on the left hand side of the chart extend out horizontally until the line meets the curved 8 bar upstream line. At this point read vertically downwards where it will be seen that a 1/2" SRV2S will be required.

**Dimensions (approximate) in mm and kg**

Size	A	B	B	C	D	*E1	*E2	F
1/2" BSP/NPT	83	-	-	62	130	25	15	-
DN15	PN25	-	150	-	62	130	25	15
	ANSI 150	-	-	140	62	130	25	15
3/4" BSP/NPT	96	-	-	62	130	25	15	-
DN20	PN25	-	150	-	62	130	25	15
	ANSI 150	-	-	140	62	130	25	15
1" BSP/NPT	108	-	-	62	130	25	15	-
DN25	PN25	-	160	-	62	130	25	15
	ANSI 150	-	-	153	62	130	25	15

\* Note: E1 and E2 are withdrawal distances for maintenance.

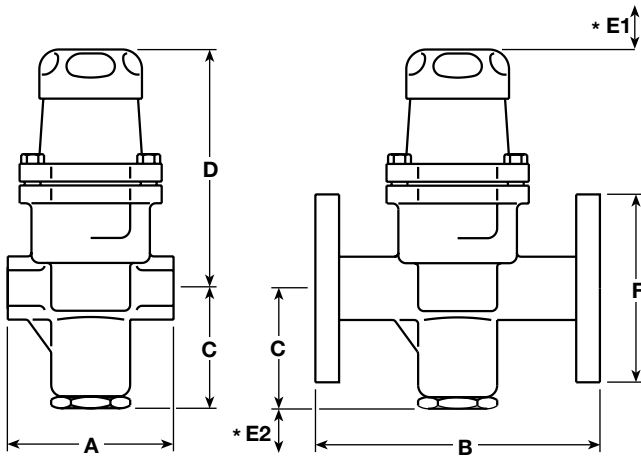

**Weights (approximate) in mm and kg**

Size		Weight	
		Screwed	Flanged
1/2"	BSP/NPT	1.48	-
DN15	PN25	-	3.1
	ANSI 150	-	2.4
3/4"	BSP/NPT	1.58	-
DN20	PN25	-	3.8
	ANSI 150	-	2.8
1"	BSP/NPT	1.70	-
DN25	PN25	-	4.4
	ANSI 150	-	3.6

**Safety information, installation and maintenance**

For full details see the Installation and Maintenance Instructions (IM-P186-03) supplied with the product.

**Installation note:**

The valve should be installed in a horizontal pipeline with the direction of flow as indicated by the arrow on the valve body.

**How to order**

**Example:** 1 off Spirax Sarco 1/2" screwed BSP SRV2S pressure reducing valve with stainless steel body and bellows, fitted with an orange spring for a downstream pressure control of 3.5 to 8.6 bar g.

**Spare parts**

The spare parts available are shown in heavy outline. Parts drawn in broken line are not supplied as spares.

**Available spares**

* Pressure adjustment spring	Grey	0.14 to 1.7 bar g	<b>4, 18</b>
	Green	1.40 to 4.0 bar g	<b>4, 18</b>
	Orange	3.50 to 8.6 bar g	<b>4, 18</b>
* Bellows (Stainless steel)			<b>5, 6</b>
* Spring housing hex. bolts (set of 4)			<b>7</b>
Valve and seat assembly			<b>6, 11, 12, 15, 19</b>
* Set of gaskets/'O' rings			<b>6, 12, 17</b>
* Common to all sizes.			

**How to order spares**

Always order spares by using the description given in the column headed 'Available spares' and state the size, type and pressure range of the reducing valve.

**Example:** 1 off Pressure adjustment spring (orange), having a downstream pressure range of 3.5 to 8.6 bar g for a Spirax Sarco DN15 SRV2S pressure reducing valve.

