



Spira-trol™ Two-port Control Valves

EN Standard K and L Series DN15 to DN100

Description

Spira-trol™ is a range of two-port single seat globe valves with cage retained seats conforming to EN standard. These valves are available in four body materials in sizes ranging from DN15 to DN100. When used in conjunction with a pneumatic or electric linear actuator they provide characterised modulating or on/off control.

Important note: Throughout this document, reference has been made to the standard KE or LE control valve. With the exception of trim type, the KE, LE, KF, LF, KL and LL control valves are identical.

BSP threaded connections are to standard BSP T Rp (ISO 7-1).

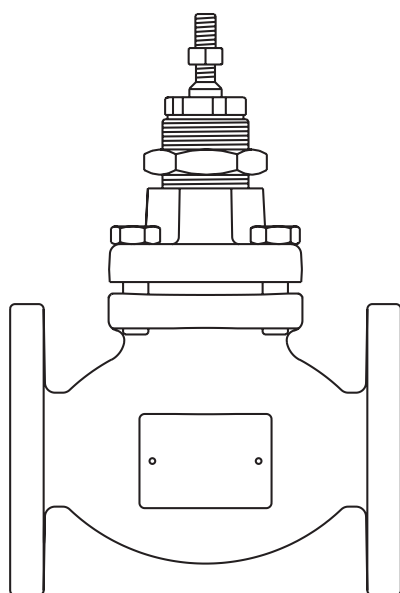

L Series
 DN15 to DN100

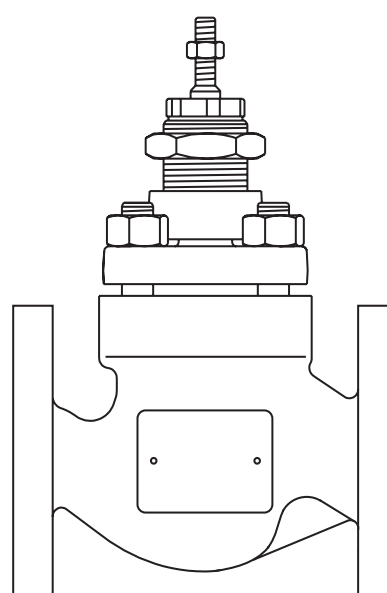

K Series
 DN15 to DN100

Sizes and pipe connections

Valve Series	Material	Screwed	Flanged					
		BSP	PN16	PN16	PN25	PN40	JIS/KS10	JIS/KS20
		Up to DN50	DN65 and DN100 ¹	DN15-DN100				
L Series	Cast Iron	•		•				
	Carbon Steel			•			•	
	Stainless Steel			•			•	
K Series	SG Iron	•	•		•		•	
	Carbon Steel					•		•
	Stainless Steel	•				•		•

¹ For others size use PN25 body which are dimensionally identical to PN16.

Compliance

The Spira-trol™ control valve when coupled to the PN9000 series or AEL7 actuator (as defined in the technical information sheets TI-P357-30 and TI-P713-02) complies with the requirements of Machinery Directive 2006/42EC. Please refer to the installation and maintenance instructions for the PN9000 series (IM-P357-29) and the Spira-trol™ valve (IM-S24-42) and the AEL7 (IM-P713-01) for potential hazards and safety information relating to the installation, commissioning, maintenance and disposal of the product assembly and its component parts.

Standards

Designed in accordance with EN 60534. This product fully complies with the requirements of the European Pressure Equipment Directive 2014/68/EU and carries the  mark when so required.

Certification

This product is available with certification to EN 10204 3.1.

Note: All certification/inspection requirements must be stated at the time of order placement.

Food contact

This product is not to be used on steam, liquid or gas that either forms an ingredient of, or comes into direct contact with food products in the EU.

For up to date information on product compliance please visit : www.spiraxsarco.com/product-compliance

Spira-trol™ valve characteristic - options:

KE and LE **Equal percentage (E)** - Suitable for most modulating process control applications providing good control at all flowrates.

KF and LF **Fast opening (F)** - For on/off applications only.

KL and LL **Linear (L)** - Primarily for liquid flow control where the differential pressures across the valve is constant.

Spira-trol™ valve options:

Stem sealing	PTFE chevron seals (P-N)	Standard
	Graphite packing (H)	High temperature applications
	Bellows/graphite secondary seals (D)	Zero emissions and high temperature applications PN25 - Up to 400 °C
Seating	Metal-to-metal	431 stainless steel - standard 316L stainless steel
	Soft seating	Up to 152 °C - PTFE for Class VI shut-off for low temperature applications. Up to 220°C - PEEK (C and P) for Class VI shut-off
	Hard facing	316L stainless steel with Stellite™ 6 facing
	Bonnet type	Standard bonnet Extended bonnet for hot/cold applications (Only available on K Series)
Trim	Standard trim	
		Low noise and anti-cavitation trim (see TI-S24-59). Not available with Reverseable PEEK Seat (C)

Spira-trol™ is a modular valve based on 4 body sizes covering DN15-100 (DN15-25, DN32-50, DN65-80, DN100) sizes in order to reduce the number of spare parts. The valves are available with a range of accessories including actuators, positioners, solenoid valves, limit switches.

Please refer to respective data sheets.	For Special trims please refer to	TI-S24-59
	For ASME version please refer to	TI-S24-72
	For smart positioner please refer to	TI-P706-01, TI-P706-04 and TI-P707-02
	For pneumatic positioners please refer to	TI-P704-01
	For electro-pneumatic positioners please refer to	TI-P703-01 and TI-P703-03
	For large size Spira-trol™ please refer to	TI-S24-73

Materials - DN15 to DN100 (1/2" to 4")

	LE3		KE7	LE-KE4		LE-KE6	
	DN15-50	DN65-100	DN15-100	DN15-50	DN65-100	DN15-50	DN65-100
1 Body	EN1563 : ENGJS-400-18		EN1563 : ENGJS-400-18LT	EN10273 : 1.0460	EN10213 : 1.0619N	EN10213 : 1.4408	
2 Bonnet	EN1563 : ENGJS-400-18	EN1561 : ENGJL-250	EN1563 : ENGJS-400-18LT	EN10213 : 1.0619N		EN10213 : 1.4408	
2a Bonnet extension	EN10213 : 1.0619N					EN10213 : 1.4408	
2b Bellows	Stainless steel 316L						
2c Extended bonnet	EN10213 : 1.0619N					EN10213 : 1.4408	

Alternative body and bonnet material available on request

* Graphite packing

High temperature packing	9	Lower and upper stem guide	Stellite 6
	14	Grafoil packing	Graphite rings
	10, 11, 12, 15, 17 and 19 Not used		

*
PTFE stem sealing

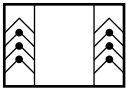

PTFE stem sealing for vacuum service

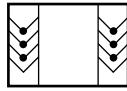

KE valve with extended bonnet (E)

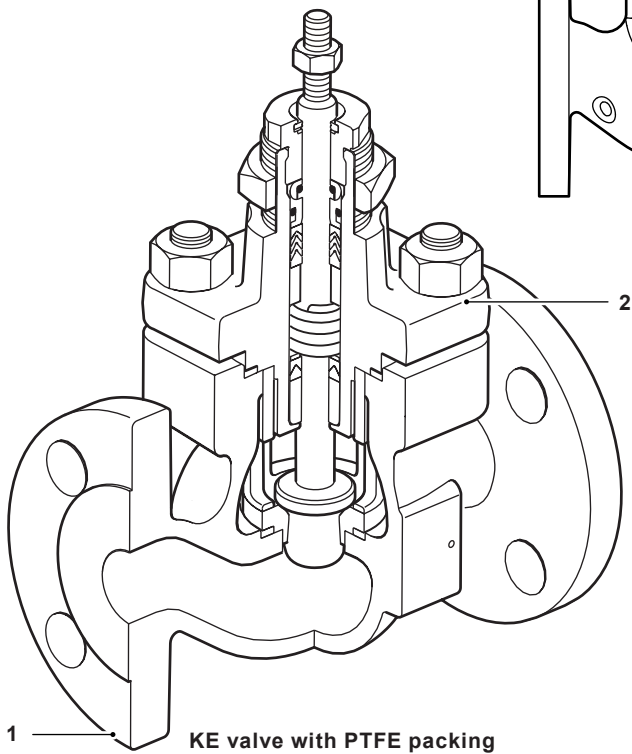
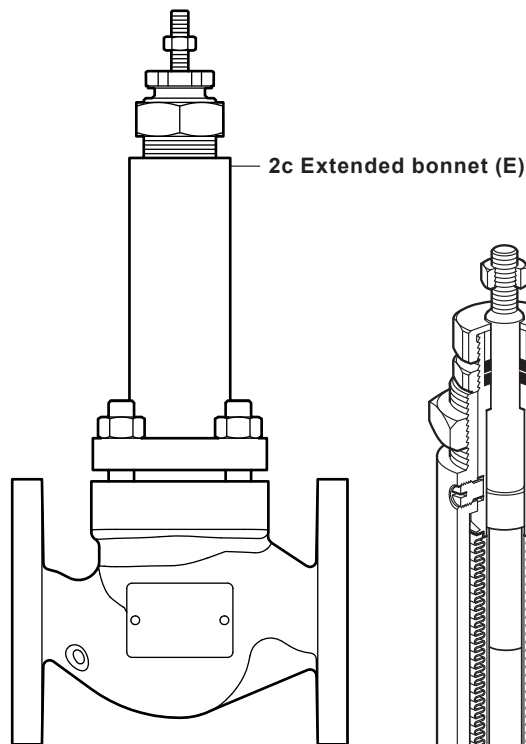

1 KE valve with PTFE packing

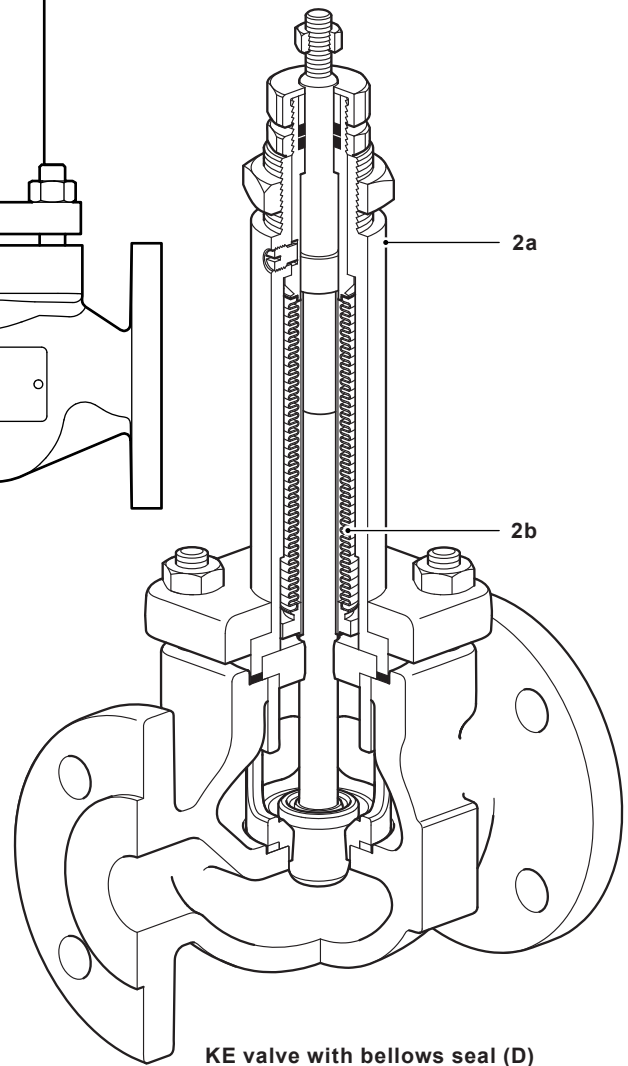

KE valve with bellows seal (D)

Materials - DN15 to DN100 (1/2" to 4") continued

3	Stem lock-nut		Stainless steel A2-70
4	Bonnet gasket		Graphite and stainless steel
5	Seat retainer		Duplex stainless steel ASME A994 CD4MCuN
6	Valve seat ring	Seat option T	Stainless steel 431
		Seat option S	Stainless steel 316L
		Seat option W	Stainless steel 316L + Stellite™ 6
		Seat option C and P	PEEK
		Seat option G	Stainless Steel 316L + PTFE
7	Seat gasket		Graphite and stainless steel
8	Valve plug and stem	Seat option T	Stainless steel 431
		Seat option S	Stainless steel 316L
		Seat option W	Stainless steel 316L + Stellite™ 6
		Seat option C/G/P	Stainless steel 316L for Stainless steel valve and Stainless steel 431 for all other materials
9	Lower stem guide	Bonnet option P	PTFE glass filled
		Bonnet option N	Nitronic™ 60
		Bonnet option H	Stellite™ 6
10	Lower stem wiper	Bonnet option P - N	PTFE
11	Packing guard washer		Stainless steel 316L
12	Spring	Bonnet option P - N	Stainless steel 316L
13	Packing spacer		Stainless steel 316L
14	Packing set	Bonnet option P - N	PTFE chevron
		Bonnet option H	Graphite rings
15	Outer 'O' ring	Bonnet option P - N	VITON™
16	Upper stem guide	Bonnet option P	PTFE glass filled
		Bonnet option N	Nitronic™ 60
		Bonnet option H	Stellite™ 6
17	Inner 'O' ring	Bonnet option P - N	VITON™
18	Gland nut		Stainless steel 316L for stainless steel valve and stainless steel 431 for all others materials
19	Scrapper ring	Bonnet option P - N	PTFE
20	Actuator clamp nut	Stainless steel valve	Nickel plated carbon steel
		All others	Zinc plated carbon steel
22	Bonnet extension gasket		Graphite and stainless steel
26	Spindle lock and anti-rotation nut		Stainless steel
27	Nut	Bolting option S	Stainless steel A2-70 for stainless steel valve and carbon steel Gr.8 for all others
		Bolting option H	Stainless steel A2-70
28	Stud	Bolting option S	Stainless steel A2-70 for stainless steel valve and carbon steel 8.8 for all others
		Bolting option H	Stainless steel A2-70

KE valve with graphite packing

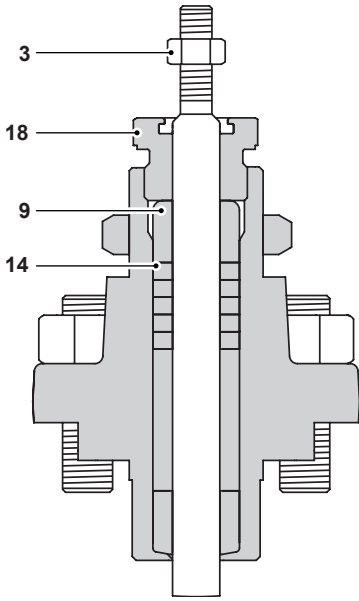

KE valve with extended bonnet (E)

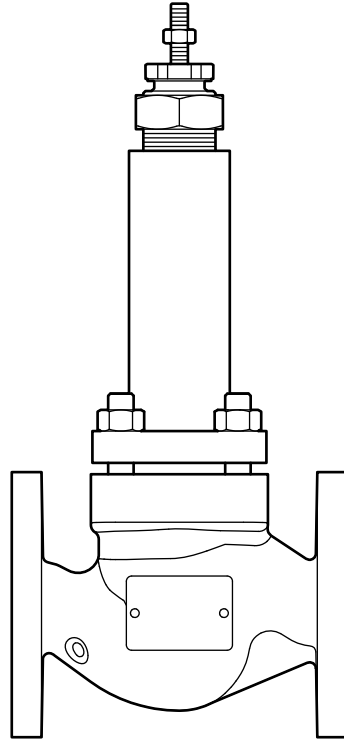

* Graphite packing

High temperature packing	9	Lower and upper stem guide	Stellite 6
	16	Grafoil packing	Graphite rings
	10, 11, 12, 15, 17 and 19 Not used		

* PTFE stem sealing

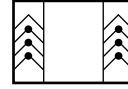

PTFE stem sealing for vacuum service

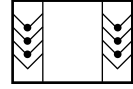

KE valve with PTFE packing

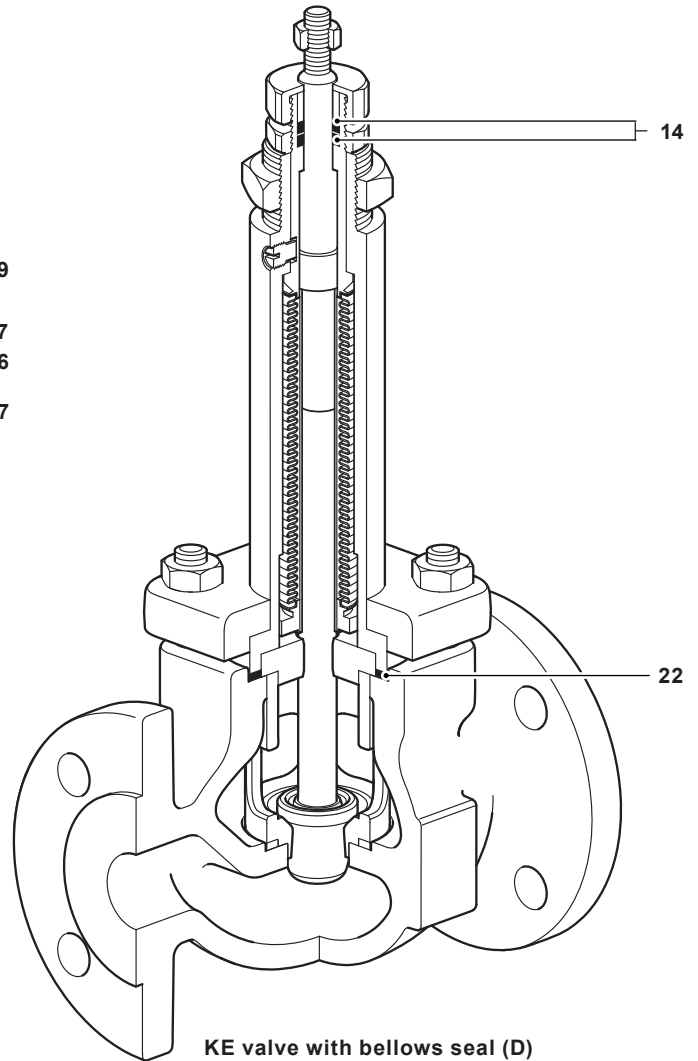
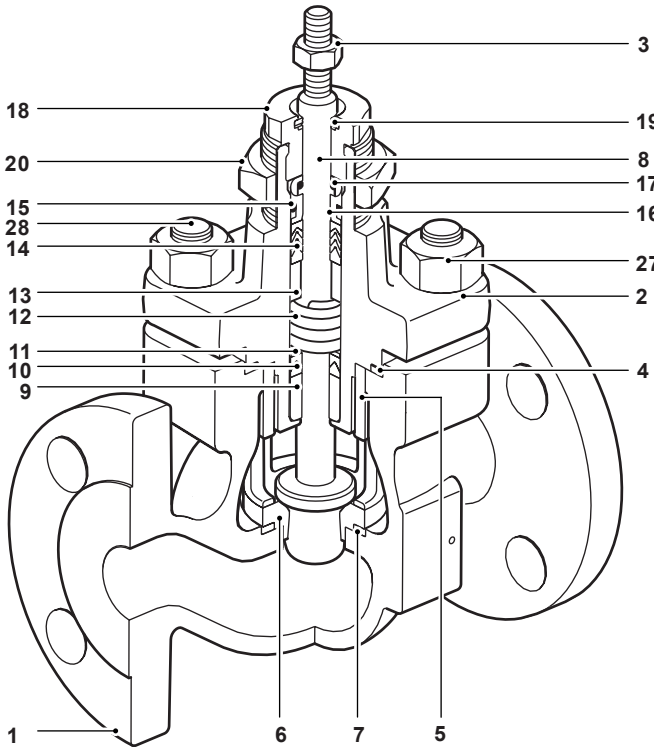

K_v values

Valve size		DN15 (½")	DN20 (¾")	DN25 (1")	DN32 (1¼")	DN40 (1½")	DN50 (2")	DN65 (2½")	DN80 (3")	DN100 (4")	
Standard trim	High capacity Equal %	4.9	7.2		17.5	31.0	46.0				
	Full port	Equal %	4.0	6.3	10.0	16.0	25.0	36.0	73	100	160
		Linear	4.0	6.3	10.0	16.0	25.0	36.0	73	100	160
		Fast opening	4.9	7.2	11.0	18.0	31.0	50.0	90	117	180
	Reduced trim 1	Equal %	2.5	4.0	6.3	10.0	16.0	25.0	36	73	100
		Linear	2.5	4.0	6.3	10.0	16.0	25.0	36	73	100
	Reduced trim 2	Equal %	1.6	2.5	4.0	6.3	10.0	16.0	25	36	63
		Linear	1.6	2.5	4.0	6.3	10.0	16.0	25	36	63
	Reduced trim 3	Equal %	1.0	1.6	2.5	4.0	6.3	10.0	16	25	36
		Linear	1.0	1.6	2.5	4.0	6.3	10.0	16	25	36
	Reduced trim 4	Equal %		1.0	1.6		4.0	6.3		16	
		Linear		1.0	1.6		4.0	6.3		16	
	Reduced trim 5	Equal %			1.0			4.0			
		Linear			1.0			4.0			
	Microflute (Linear only) (not available with C Seat option)		0.5	0.5	0.5						
			0.2	0.2	0.2						
			0.1	0.1	0.1						
			0.07	0.07	0.07						
		0.01	0.01	0.01							

Note: For low noise and anti-cavitation K_v please see TI-S24-59

Bellows D Service Life Expectancy

Valve			Process		Estimated life expectancy (operations)	
Inlet Size	Stem Ø	No. Ply	Pressure	Temperature	100% Stroke	25-75% modulation
DN15-50	12 mm	3	10.6 bar g (153.7 psi g)	20 °C (68 °F)	220,000	>2,000,000
			10.6 bar g (153.7 psi g)	185 °C (365 °F)	150,000	>2,000,000
			17.1 bar g (247.9 psi g)	400 °C (752 °F)	30,000	750,000
DN65-100	16 mm	3	10.6 bar g (153.7 psi g)	20 °C (68 °F)	200,000	>2,000,000
			10.6 bar g (153.7 psi g)	185 °C (365 °F)	140,000	2,000,000
			17.1 bar g (247.9 psi g)	400 °C (752 °F)	30,000	150,000

Note: 316L material. Refer to IM-S24-42 for valve body material pressure and temperature limitations

For Full Temperature/Pressure Operating Curves, please refer to IM-S24-42

Spira-trol series valve

Nominal Pressure		PN16	PN25	PN16	PN40	PN16	PN40
Body Material		LE3	KE7	LE4	KE4	LE6	KE6
Connection type	Flanged	PN16	DN15-100	DN65 and 100	DN15-100	DN15-100	N/A
		PN25		DN15-100			
		PN40				DN15-100	DN15-100
		JIS/KS10		DN15-100	DN15-100		DN15-100
		JIS/KS20				DN15-100	DN15-100
	Threaded BSP	DN15-50	DN15-50			DN15-50	
Maximum operating pressure	PN16	16 bar @ 120 °C	16 bar @ 120 °C	16 bar @ 50 °C		16 bar @ 100 °C	
		PN25		25 bar @ 120 °C			
	Flanged	PN40				40 bar @ 50 °C	40 bar @ 100 °C
		JIS/KS10		13,7 bar @ 120 °C	14 bar @ 120 °C		14 bar @ 120 °C
		JIS/KS20				34 bar @ 120 °C	34 bar @ 120 °C
	Threaded BSP	16 bar @ 120 °C	25 bar @ 120 °C			40 bar @ 100 °C	
Maximum operating temperature	Seat	PEEK C and P	220 °C				
		PTFE insert G	152 °C				
	431S29 T	400 °C					
	316L S						
	316L/ Stellite6 W						
Operating temperature range	Std. Bonnet	-10 to +300 °C	-10 to +300 °C	-10 to +300 °C		-10 to +300 °C	
	Ext. Bonnet		-10 to +350 °C		-10 to +400 °C	-10 to +400 °C	

Spira-trol series valve (continued on next page)

Spira-trol series valve (continued)

		Body Material	LE3	KE7	LE4	KE4	LE6	KE6
Maximum operating temperature	Stem Seal	P and N	250 °C					
		H	400 °C					
		Bellows D	400 °C					
Maximum operating temperature	Body	PN16	300 °C	350 °C	400 °C		400 °C	
		PN25		350 °C				
		Flanged PN40				400 °C		400 °C
		JIS/KS10		300 °C	300 °C		300 °C	
		JIS/KS20				400 °C		400 °C
		Threaded BSP	300 °C	350 °C	400 °C		400 °C	
Maximum saturated steam service	Body	PN16	12.9 bar g	14.6 bar g	13.3 bar g		13.4 bar g	
		PN25		22.5 bar g				
		Flanged PN40				31.1 bar g		32.2 bar g
		JIS/KS10		12.4 bar g	13 bar g	N/A	13 bar g	
		JIS/KS20				30.1 bar g		30.1 bar g
		Threaded BSP	12.9 bar g	22.5 bar g				32.2 bar g
Maximum saturated steam service	Seat	C and P	19 bar g					
		G	4 bar g					
	Bellows	D	12.9 bar g	22.5 bar g	13.3 bar g	20.2 bar g	13.4 bar g	20.6 bar g
Leakage class	In accordance to IEC 60534-4	PEEK	Class VI					
		PTFE	Class VI					
		Metal	Class IV (Class V on request)					
		Stellite™	Class IV (Class V on request)					
		Balanced	Class IV					
Characteristic	Equal %		Linear			Fast Acting		
Rangeability	50 : 1		30 : 1			10 : 1		
Travel	DN15 to DN50 : 20 mm (Reduce travel on Microflute trim) DN65 to DN100 : 30 mm							

Note: Consider the limitation of all of the constructive components when selecting a valve

Maximum differential pressures for Class IV shut-off
- Metal Seated (T&S)
- FLOW UNDER
- standard trim
- (Pneumatic Actuators)
- continued

Actuator type	DN32 to DN50																										
	Valve size			4.0			6.3			10			16			17.5 - 18			25			31-36			46-50		
	Kvs	Stem sealing	Actuator thrust	N-P	H	D	N-P	H	D	N-P	H	D	N-P	H	D	N-P	H	D	N-P	H	D	N-P	H	D			
PN9120E 0.4-1.2	384		7.9																								
PN9126E 1.0-2.0	960		40	31.5	25	30.3	15.4	23.8	17.4	7.8	13.2	13.5	5.6	10.1	9.5	3.4	6.9	3.6	0.3	2.2	2.3	1					
PN9123E 2.0-4.0	1920		40	40	25	40	40	25	40	38.4	25	38.8	30.9	25	29.1	23	25	14.2	10.9	12.7	10.8	7	5.1	6.2			
PN9220E 0.2-1.0	680		33.2	7.6	22.1	16.3	1.4	9.9	8.5	4.3	6.2	2.7			3.8	1.2	0.5										
PN9220E 0.4-1.2	1360		40	40	25	40	35.2	25	30.1	20.6	25	24.1	16.2	20.6	17.7	11.6	15	8	4.7	6.6	5.8	3.5	1.6	2.7			
PN9226E 1.0-2.0	3400		40	40	25	40	40	25	40	40	25	40	40	25	40	40	25	30.5	27.2	25	23.8	16.3	14.4	15.5			
PN9223E 2.0-4.0	6800		40	40	25	40	40	25	40	40	25	40	40	25	40	40	25	40	40	25	40	37.7	35.8	25			

Maximum differential pressures for Class IV shut-off
- Metal Seated (T&S)
- FLOW UNDER
- standard trim
- (Pneumatic Actuators)
- continued

Actuator Type	DN65 to 100																					
	Valve size			16			25			36			63-73-90			100-117			160-180			
	Kvs	Stem sealing	Actuator thrust	P	H	D	P	H	D	P	H	D	P	H	D	P	H	D	P	H	D	
PN9230E 0.2-1.0	680		2.8		1.2																	
PN9230E 0.4-1.2	1360		16.6	6.3	15	5.4	0.9	4.7	3.2	2.7	0.9	0.7										
PN9236E 1.0-2.0	3400		40	40	25	23.4	18.9	22.7	16	12.8	15.5	6.4	7.9	4.7	3.5	2.5	1.8	2.4				
PN9233E 2.0-4.0	6800		40	40	25	40	40	25	37.4	34.2	21	20.2	18.4	19.9	12.2	7.3	6.6	7.2				
PN9330E 0.2-1.0	1340		16.2	5.9	14.6	5.2	0.7	4.5	3	2.5	0.9	0.6										
PN9330E 0.4-1.2	2680		40	33.2	25	17	12.5	16.3	11.5	8.3	11	5.6	3.8	5.3	3.1	1.9	2.9	1.5	0.7	1.4		
PN9336E 1.0-2.0	6700		40	40	25	40	40	25	36.7	33.5	25	19.8	18	19.5	12.2	11	12	7.1	6.4	7		
PN9337E 2.5-3.5	16750		40	40	25	40	40	25	40	40	25	40	25	34.9	33.8	25	21.3	20.6	21.2			

Maximum differential pressures for Class IV shut-off
- Metal Seated (T&S)
- FLOW UNDER
- standard trim
- (Electric Actuators)

Acuator Type	Valve DN		DN15 to DN25																												
	Kvs	Stem sealing Actuator thrust	Up to 0,2			0.5-1.0			1.6			2.5			4.0			4.9-6.3			7.2			10			11				
			N-P	H	D	N-P	H	D	N-P	H	D	N-P	H	D	N-P	H	D	N-P	H	D	N-P	H	D	N-P	H	D	N-P	H	D		
AEL3	2000		40	40	25	40	40	25	40	40	25	40	40	25	40	40	25	40	40	25	40	40	25	40	38.3	30.5	25	38.3	30.5	25	
AEL71T	900		40	40	25	40	40	25	40	40	25	40	39.7	25	40	24.2	25	40	24.8	9.9	18.3	18.1	6.3	13	13.5	3.9	9.3	9.9	2.1	6.5	
AEL71	1200		40	40	25	40	40	25	40	40	25	40	40	25	40	40	25	39.7	24.8	25	29.9	18.1	24.8	23	13.5	18.9	17.6	9.9	14.2		
AEL72/82	2000		40	40	25	40	40	25	40	40	25	40	40	25	40	40	25	40	40	25	40	40	25	40	38.3	30.5	25	38.3	30.5	25	
AEL72T	2100		40	40	25	40	40	25	40	40	25	40	40	25	40	40	25	40	40	25	40	40	25	40	40	40	33.1	25	40	25	
AEL73	4000		40	40	25	40	40	25	40	40	25	40	40	25	40	40	25	40	40	25	40	40	25	40	40	40	40	40	40	25	25
AEL83	4500		40	40	25	40	40	25	40	40	25	40	40	25	40	40	25	40	40	25	40	40	25	40	40	40	40	40	40	25	25

Maximum differential pressures for Class IV shut-off
 - Metal Seated (T&S)
 - FLOW UNDER
 - standard trim
 - (Electric Actuated)
 - continued

Actuator Type	DN65 to DN100																							
	Valve size			16			25			36			63-73			100-117			160-180					
	Kvs	Stem sealing	Actuator thrust	P	H	D	P	H	D	P	H	D	P	H	D	P	H	D	P	H	D			
AEL71T	900		7.3	5.6	1.3	0.6	0.3																	
AEL71	1200		13.4	3	11.8	3.3	2.2	1.7	0.4	0.1														
AEL72/82	2000		29.7	19.3	25	11	6.6	10.3	7.2	4	6.7	3.2	1.4	2.9	1.5	0.4	1.3	0.5	0.4					
AEL72T	2100		31.7	21.3	25	11.9	7.4	11.2	7.8	4.6	7.3	3.6	1.8	3.3	1.7	0.6	1.6	0.6	0.5					
AEL73	4000		40	40	25	28.7	24.2	25	19.8	16.6	19.3	10.3	8.5	10	6	4.9	5.9	3.3	2.6	3.2				
AEL74/84	6000		40	40	25	40	40	25	32.3	29.1	25	17.4	15.6	17.1	10.6	9.4	10.4	6.1	5.4	6				
AEL75/85	8000		40	40	25	40	40	25	40	40	25	24.4	22.6	24.1	15.1	13.9	14.9	9	8.2	8.9				
AEL76/86	12000		40	40	25	40	40	25	40	40	25	38.6	36.8	25	24.2	23	24	14.6	13.9	14.5				
AEL77/87	15000		40	40	25	40	40	25	40	40	25	40	40	25	30.9	29.8	25	18.8	18.1	18.7				
AEL78	20000		40	40	25	40	40	25	40	40	25	40	40	25	40	40	25	25.9	25.2	25				
AEL83	4500		40	40	25	40	40	25	40	40	25	40	40	25	40	40	25	25.9	25.2	25				
			Only for 431 trim																					

Maximum differential pressures for Class VI shut-off
- Resilient Seated (P&C)
- FLOW UNDER
- standard trim
- (Pneumatic Actuators)
- continued

Actuator Type	DN32 to DN50																																			
	Valve size						16						17.5 - 18						25						31-36						46-50					
	Kvs			4.0			6.3			10			16			17.5 - 18			25			31-36			46-50											
	Stem sealing	Actuator thrust	N-P	H	D	N-P	H	D	N-P	H	D	N-P	H	D	N-P	H	D	N-P	H	D	N-P	H	D	N-P	H	D										
PN9126E 1.0-2.0			960	19	19	16	19	19	16	19	13.8	16	19	11.1	15.6	14.3	8.2	11.7	7.1	3.8	5.7	2.8	4.3	3.6	1.7	2.8										
PN9123E 2.0-4.0	1920	19	19	16	19	19	16	19	19	16	19	19	16	19	19	16	17.7	14.4	16	13.9	11.3	12.8	9.7	7.8	8.8											
PN9220E 0.2-1.0	680	19	17.4	16	19	8.9	16	14.5	4.9	10.3	3.7	8.2	11.6	8.6	2.5	6	4	0.7	2.6	3	0.4	1.9	1.9	1.1												
PN9220E 0.4-1.2	1360	19	19	16	19	19	16	19	19	16	19	19	16	19	16.4	16	11.5	8.2	10.1	9	6.4	7.9	6.1	4.3	5.3											
PN9226E 1.0-2.0	3400																				19	19	16	19	16											

Actuator Type	DN65 to 100																																									
	Valve size						16						25						36						63-73-90						100-117						160-180					
	Kvs			16			25			36			63-73-90			100-117			160-180																							
	Stem sealing	Actuator thrust	P	H	D	P	H	D	P	H	D	P	H	D	P	H	D	P	H	D	P	H	D	P	H	D																
PN9230E 0.2-1.0			680	7.6	6	19	2.6	1.9	1.6	1.1	0.5	0.3	0.1																													
PN9230E 0.4-1.2	1360	19	11.1	19	8.6	4.1	7.9	5.8	2.9	1.1	2.7	1.7	0.5	1.5	0.9	0.1	0.8																									
PN9236E 1.0-2.0	3400				19	19	18.7	15.5	18.2	10.2	8.4	9.9	6.3	5.1	6.1	3.7	3	3.6																								
PN9233E 2.0-4.0	6800								19	19	19	14	12.8	13.8	8.5	7.8	8.4																									
PN9330E 0.2-1.0	1340	19	10.7	19	8.4	3.9	7.7	5.7	2.9	1.1	2.6	1.6	0.5	1.4	0.8	0.1	0.7																									
PN9330E 0.4-1.2	2680				19	15.7	19	14.1	10.9	13.6	7.3	5.8	4.7	3.5	4.5	2.7	2	2.6																								
PN9336E 1.0-2.0	6700								19	19	19	13.8	12.6	13.6	8.4	7.7	8.3																									
PN9337E 2.5-3.5	16750																						19	19	19																	

Note : Maximum differential pressure for saturated steam. Refer to Spirax Sarco for other liquids or gases.

Maximum differential pressures for Class VI shut-off
- Resilient Seated (P&C)
- FLOW UNDER
- standard trim
- (Electric Actuators)

Actuator Type	Valve size												
	DN15 to DN25												
	Kvs	Upto Kv6.3			7.2			10			11		
		P	H	D	P	H	D	P	H	D	P	H	D
AEL3	10	10	10	10	10	10	10	10	10	10	10	10	
AEL71T	19	19	19	19	15.2	19	19	11.9	17.3	17.1	9.3	13.7	
AEL71	19	19	19	19	19	19	19	19	19	19	17.1	19	
AEL72/82	19	19	19	19	19	19	19	19	19	19	19	19	

Actuator Type	Valve size																								
	DN32 to DN50																								
	Kvs	4			6.3			10			16			17.5-18			25			31-36			46-50		
		P	H	D	P	H	D	P	H	D	P	H	D	P	H	D	P	H	D	P	H	D	P	H	D
AEL3	10	10	10	10	10	10	10	10	10	10	10	10	10	10	10	10	10	10	10	10	10	10	10.2	8.3	9.4
AEL71T	19	19	19	19	19	19	19	11.9	17.3	17.4	9.5	14	7	10.4	6.5	3.2	5	4.9	2.3	3.8	3.3	1.4	2.4	2.4	2.4
AEL71	19	19	19	19	19	19	19	19	19	19	17.4	19	13.1	16.6	9.8	6.5	8.3	7.6	4.9	6.4	5.1	3.3	4.3	4.3	4.3
AEL72/82	19	19	19	19	19	19	19	19	19	19	19	19	19	19	18.6	15.3	17.1	14.6	12	13.5	10.2	8.3	9.4	9.4	9.4
AEL72T																			15.5	12.9	14.1	10.8	8.9	10	10
AEL83																			17.3	14.6	16.1	12.1	10.2	11.2	11.2

Note : Maximum differential pressure for saturated steam. Refer to Spirax Sarco for other liquids or gases.

Maximum differential pressures for Class VI shut-off
- Resilient Seated (P&C)
- FLOW UNDER
- standard trim
- (Electric Actuators)
- continued

Actuator Type	Valve size	DN65 to DN100																	
		16			25			36			63-90			100-117			160-180		
		P	H	D	P	H	D	P	H	D	P	H	D	P	H	D			
	Kvs																		
	Stem sealing																		
	Actuator thrust																		
AEL71T	900	12.1	1.7	10.4	4.5	3.8	2.9	2.4	1.3	1									
AEL71	1200	18.2	7.8	16.6	7.2	2.7	4.8	4.3	2.4	0.6	2.1	1.3	1.1	0.6					0.5
AEL72/82	2000	19	19	19	14.2	9.7	9.9	6.6	5.2	3.4	4.9	3.1	2	1.8	1	1.7			
AEL72T	2100	15.1	4.7	19	14.2	9.7	10.5	7.3	10	5.6	3.8	5.3	2.2	1.9	1.2	1.8			
AEL73	4000								12.3	10.5	12	7.6	6.5	7.5	4.6	3.9	4.5		
AEL74/84	6000								19	17.6	19	12.2	11	12	7.4	6.7	7.3		
AEL75/85	8000											16.7	15.5	16.5	10.2	9.5	10.1		
AEL76/86	12000														15.9	15.2	15.8		
AEL77/87	15000														19	19	19		
AEL83	2300 (reduced thrust)	19	19	19	16.8	12.3	10.5	7.3	10										
	4500								12.3	10.5	12	7.6	6.5	7.5	4.6	3.9	4.5		

Note : Maximum differential pressure for saturated steam. Refer to Spirax Sarco for other liquids or gases.

Dimensions for the **Spira-trol™ two-port control valve** approximate in mm and (inches)

Valve size	Screwed BSP			Flanged			D	Thread	Bellows seals and extended bonnet	
	A	B	C	A1	C1	F				
						mm			inches	
DN15 (1/2")	130	40	103	130	124	103	69 (2 3/4")	M8	216	8.5
DN20 (3/4")	155	45	103	150	144	103			218	8.58
DN25 (1")	160	50	103	160	160	103			214	8.42
DN32 (1 1/4")	185	60	132	180	176	132			243	9.57
DN40 (1 1/2")	205	65	132	200	198	132			238	9.37
DN50 (2")	230	80	127	230	222	127	81 (3")	M12	351	13.82
DN65 (2 1/2")				290	290	201			365	14.37
DN80 (3")				310	310	201				
DN100 (4")				350	350	216				

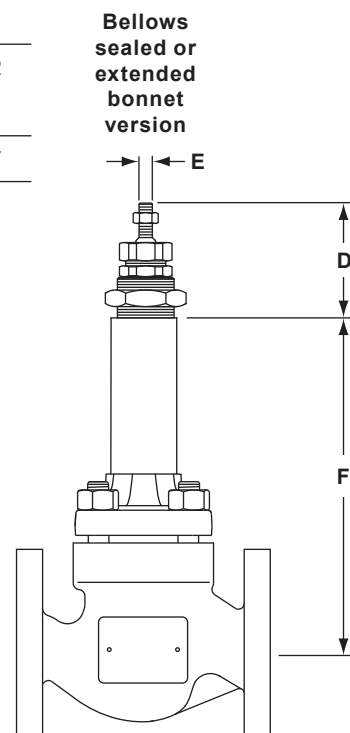
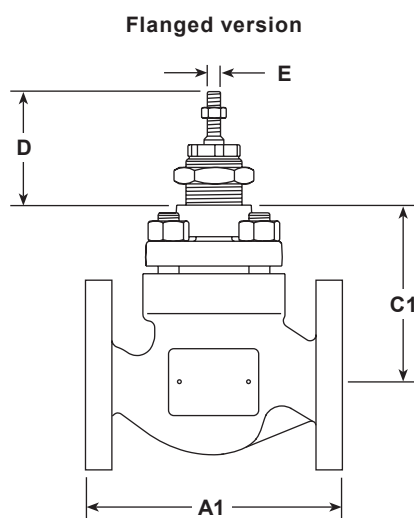
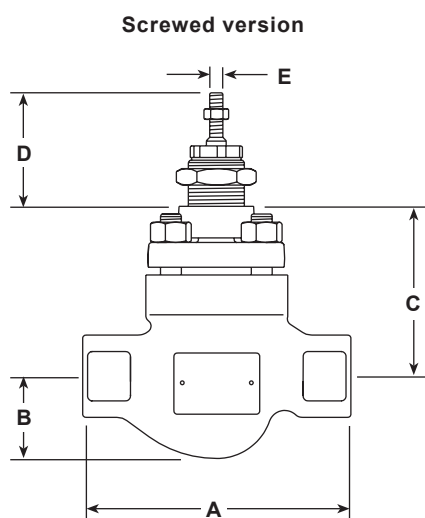

Weights approximate in kg (and lbs)

Valve size	KE valves					LE valves				Additional bellows and Extended bonnet
	KE43	KE61	KE63	KE71	KE73	LE31	LE33	LE43	LE63	
DN15 (1/2")	6.0	4.5	5.5	4.5	5.5	4.0	5.0	5.0	5.0	4.5 (10)
DN20 (3/4")	6.8	5.5	6.8	5.5	6.8	5.0	6.0	6.0	6.0	
DN25 (1")	7.0	6.0	7.0	6.0	7.0	5.5	6.5	6.5	6.5	
DN32 (1 1/4")	13.5	11.5	13.5	11.5	13.5	9.0	10.0	10.0	10.0	5.5 (12)
DN40 (1 1/2")	14.0	12.0	14	12.0	14.0	10.0	12.8	12.8	12.8	
DN50 (2")	17.0	13.0	17.0	13.0	17.0	11.0	15.0	15.0	15.0	
DN65 (2 1/2")	35.0		35.0		35.0	-	32.0	32.0	32.0	10 (21)
DN80 (3")	40.0		40.0		40.0	-	36.0	36.0	36.0	
DN100 (4")	54.0		54.0		54.0	-	53.0	53.0	53.0	

Dimensions/weights for the **PN actuator range** approximate in mm and kgs (inches and lbs)

Actuator range and variants	F		G		H		J		Weight			
	mm	inches	mm	inches	mm	inches	mm	inches	Actuator		With handwheel	
									kg	lbs	kg	lbs
PN9100E	170	6 ¹ / ₁₆ "	275	10 ⁷ / ₈ "	55	2 ³ / ₁₆ "	225	8 ⁷ / ₈ "	6	13.25	+5.86	+13.00
PN9100R					140	5 ¹ / ₂ "					+2.50	+5.50
PN9200E	300	11 ¹ / ₈ "	300	11 ¹ / ₈ "	55	2 ³ / ₁₆ "	225	8 ⁷ / ₈ "	17	37.50	+7.20	+15.75
PN9200R					140	5 ¹ / ₂ "					+3.77	+8.50
PN9320E	390	15 ¹ / ₂ "	325	12 ³ / ₈ "	65	2 ⁹ / ₁₆ "	350	13 ³ / ₄ "	27	59.50	+7.20	+15.75
PN9320R					150	15 ⁵ / ₈ "					+3.77	+8.50
PN9330E	390	15 ¹ / ₂ "	335	13 ³ / ₈ "	65	2 ⁹ / ₁₆ "	350	13 ³ / ₄ "	27	59.50	+7.20	+15.75
PN9330R					150	15 ⁵ / ₈ "					+3.77	+8.50
TN2100E	405	16"	369	14 ¹ / ₂ "	402	15 ⁵ / ₈ "	330	13"	37	83.25	+23.00	+51.75
TN2100R												
TN2100DA	405	16"	369	14 ¹ / ₂ "					30	67.50		

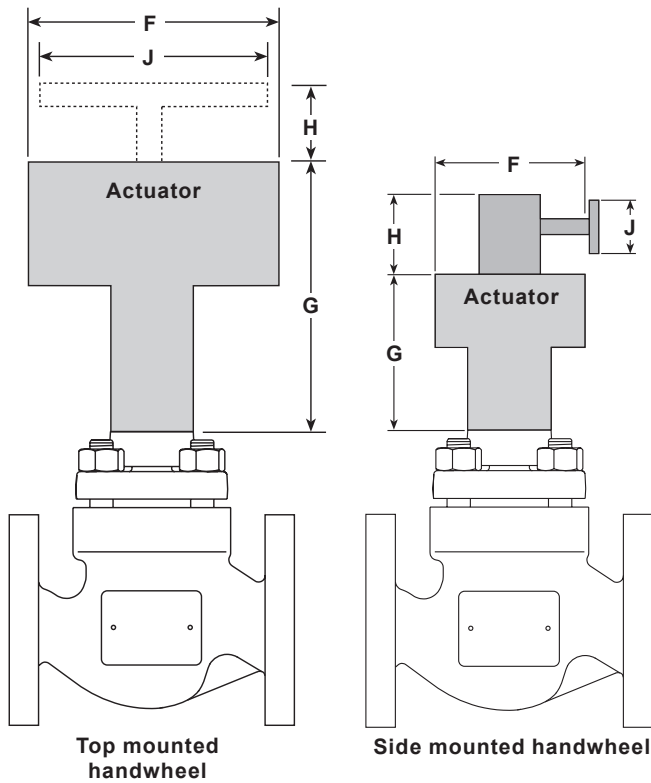

Dimensions/weights for the **AEL actuator ranges**

approximate in mm and kgs (and in inches and lbs)

Actuator	F		G		Weight	
	mm	inches	mm	inches	kg	lbs
AEL3	230	9	283	11 ¹ / ₄	5.7	12.5
AEL71T	162	6	490	19 ¹ / ₄	8.7	19.5
AEL72T			508	20	9.3	20.5
AEL71	129	5	292	11 ¹ / ₂	2.1	5
AEL72-3	173	7	379	15	4.8	11
AEL74	211	8 ¹ / ₄	474	18 ³ / ₄	8.0	18
AEL75-7	259	10 ¹ / ₄	527	20 ³ / ₄	15.0	33
AEL78	283	11 ¹ / ₄	657	26	19.0	42
AEL62-3	180	7	459	18	5.0	11
AEL64			490	19 ¹ / ₄	7.0	15.5
AEL65			557	22	10.0	22
AEL66	226	9	760	30	20.0	44

Spare parts

Spira-trol™ two-port control valve DN15 to DN100 - 1/2" to 4"

The spare parts available are shown in solid outline. Parts drawn in a grey line are not supplied as spares.

Note: When placing an order for spare parts please specify clearly the full product description as found on the label of the valve body, as this will ensure that the correct spare parts are supplied.

Available spares - K series

Actuator clamping nut		A
Gasket set	(Non-bellows sealed)	B, G
	PTFE packing	C
Stem seal kits	Graphite packing	C1
	Graphite seal set	C2
Plug stem and seat kit	* Equal percentage trim (No gaskets supplied)	D, E
	Fast opening trim (No gaskets supplied)	D1, E
	Linear trim (No gaskets supplied)	D2, E
PTFE soft seat seal		H

* Specify if reduced trim.

How to order spares

Always order spares by using the description given in the column headed 'Available spares', and state the size and type of valve including the full product description of the product.

Example:

1 - PTFE stem seal kit for a Spirax Sarco DN25 Spira-trol™ two-port KE43 PTSUSS.2 K_v 10 control valve.

How to fit spares

Full fitting instructions are given in the Installation and Maintenance Instructions supplied with the spare.

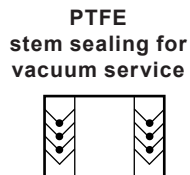
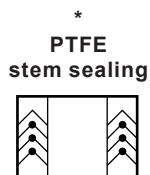
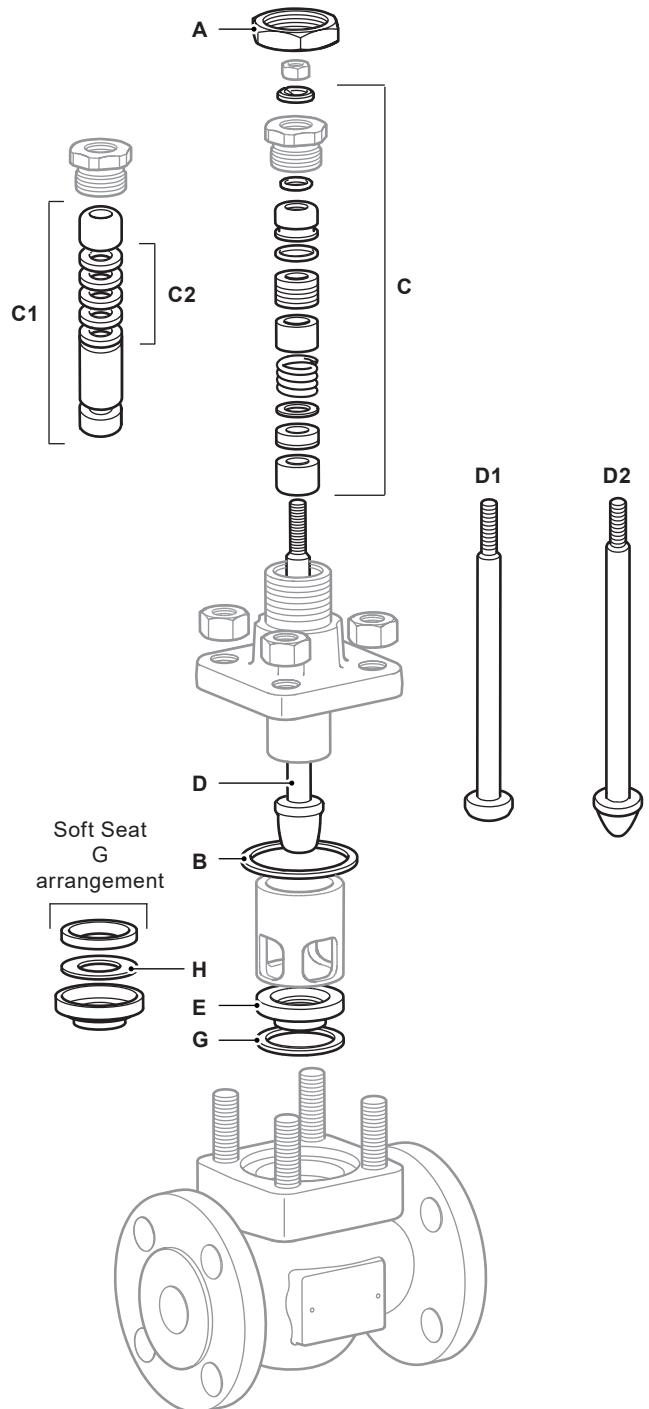

Spare parts

Spira-trol™ two-port control valve with bellows seal - Type D DN15 to DN100 - 1/2" to 4"

The spare parts available are shown in solid outline. Parts drawn in a grey line are not supplied as spares.

Note: When placing an order for spare parts please specify clearly the full product description as found on the label of the valve body, as this will ensure that the correct spare parts are supplied.

Available spares - K series

Actuator clamping nut		A
Gasket set	(Bellows sealed)	B, G
Stem seal kit	Graphite secondary seal and gasket set	C3
	*Equal percentage trim (No gaskets supplied)	D6, E
Plug stem and seat kit	Fast opening trim (No gaskets supplied)	D7, E
	Linear trim (No gaskets supplied)	D8, E
Bellows seal assembly		F
PTFE soft seat seal		H

* Specify if reduced trim.

How to order spares

Always order spares by using the description given in the column headed 'Available spares', and state the size and type of valve including the full product description of the product.

Example:

1 - Graphite stem seal kit for a Spirax Sarco DN25 Spira-trol™ two-port KE43 DTSUSS.2 Kv 10 control valve.

How to fit spares

Full fitting instructions are given in the Installation and Maintenance Instructions supplied with the spare.

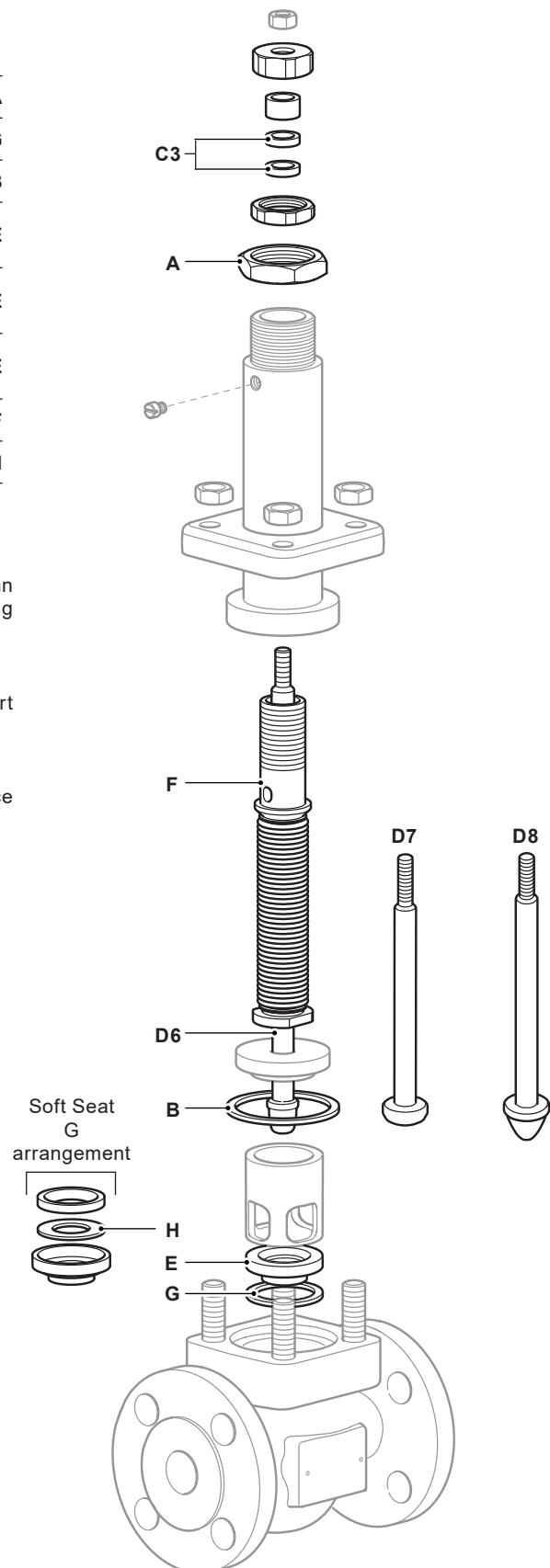

Spira-trol™ selection guide:

Valve size	EN standard = DN15, DN20, DN25, DN32, DN40, DN50, DN65, DN80 and DN100	DN25
Valve series	K = K series 2-port control valve L = L series 2-port control valve	K
Valve characteristic	E = Equal percentage F = Fast opening L = Linear	E
Flange type	Blank = EN (PN)	Blank
Flow	Blank = under T = over	Blank
Body material	3 = Cast iron 4 = Carbon steel 6 = Stainless steel 7 = SG iron	4
Connections	1 = Screwed 3 = Flanged	3
Stem sealing	D = Bellows/graphite secondary seals H = Graphite N = PTFE with Nitronic bush - DN15 to DN50 only P = PTFE V = PTFE for vacuum service	P
Seating	C = Steam-Tight Reversible PEEK seat G = PTFE soft seat P = Full PEEK S = 316L stainless steel T = 431 stainless steel W = 316L with stellite™ 6 facing	T
Type of trim	A1 = 1 stage anti-cavitation A2 = 2 stage anti-cavitation P1 = 1 stage low noise cage P2 = 2 stage low noise cage P3 = 3 stage low noise cage S = Standard trim	S
Trim balancing	B = Balanced (not available with seating option C) U = Unbalanced	U
Bonnet type	E = Extended (Only available for K Series) S = Standard	S
Bolting	H = High temperature S = Standard	S
Series	2 = .2	.2
Kvs	To be specified	Kv 16
Connection type	To be specified	Flanged PN40

Selection example:

DN32	-	K	E	4	3	P	T	S	U	S	S		.2	-	Kv 16	-	Flanged PN40
------	---	---	---	---	---	---	---	---	---	---	---	--	----	---	-------	---	--------------

How to order

Example: 1 off Spirax Sarco Spira-trol™ DN32 KE43PTSUSS.2 Kv 16 two-port control valve having flanged PN40 connections.