



Spira-trol™ Two-port Control Valves

EN Standard JE, JF and JL DN15 to DN200 and ASME Standard JEA, JFA and JLA 1/2" to 8"

Description

Spira-trol™ is a range of two-port single seat globe valves with cage retained seats conforming to EN and ASME standard. These valves are available in three body materials in sizes ranging from DN15 to DN200 (1/2" to 8"). When used in conjunction with a pneumatic or electric linear actuator they provide characterized modulating or on/off control.

Spira-trol™ valve characteristic - options:

JE	Equal percentage (E) - Suitable for most modulating process control applications providing good control at all flowrates.
JF	Fast opening (F) - For on/off applications only.
JL	Linear (L) - Primarily for liquid flow control where the differential pressures across the valve is constant.

Important note: Throughout this document, reference has been made to the standard JE control valve. With the exception of trim type, the JE, JF and JL control valves are identical.

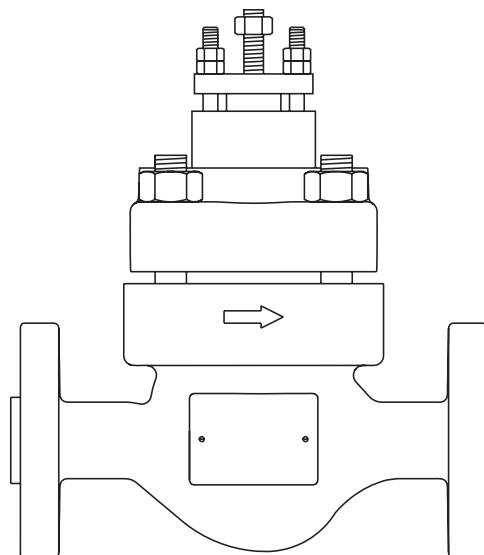

Spira-trol™ valve options:

Stem sealing	PTFE chevron seals	Standard
	Graphite packing	High temperature applications
Seating	Metal-to-metal	431 stainless steel - standard 316L stainless steel
	Soft seating	Up to 200 °C - PTFE for Class VI shut-off Up to 250 °C - PEEK for Class VI shut-off
	Hard facing	316L stainless steel with Stellite 6 facing -for more arduous applications
Bonnet type	Standard bonnet	
	Extended bonnet	for large pipe lagging or hot/cold applications
Trim	Standard trim	
	Low noise and anti-cavitation trim	

Spira-trol™ valves are compatible with the following actuators and positioners:

Electric	AEL5 and AEL6
Pneumatic	PN9000, TN2000 and PN1000

Refer to relevant Technical Information sheet for further details

Standards

Designed in accordance with EN 60534. This product fully complies with the requirements of the Pressure Equipment Equipment Directive (PED) and carries the  mark when so required.

Certification

This product is available with certification to EN 10204 3.1.

Note: All certification/inspection requirements must be stated at the time of order placement.

Technical data

Plug design	Parabolic	
	Class IV	
	Metal-to-metal	Class V
Leakage		
	Soft seal	Balanced Class IV
		Unbalanced Class VI
Rangeability	50:1	
	DN15 to DN50	20 mm
Travel	DN65 to DN100	30 mm
	DN125 to DN200	70 mm

Typical flow characteristic curves

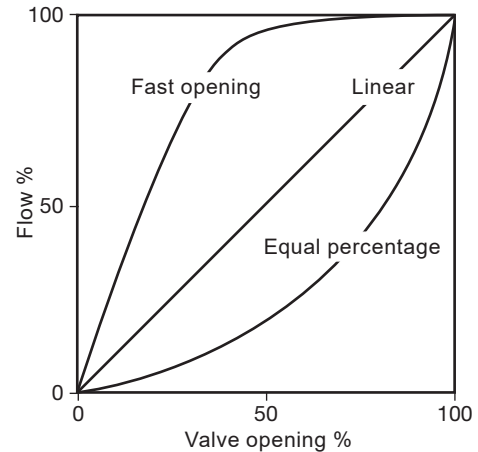

Sizes and pipe connections

Standard	EN	JE, JF and JL	DN15, DN20, DN25, DN32, DN40, DN50, DN65, DN80, DN100, DN125, DN150 and DN200
	ASME	JEA, JFA and JLA	½", ¾", 1", 1¼", 1½", 2", 2½", 3", 4", 5", 6" and 8"
Flanged	EN	Standard	EN 1092 PN63 and PN100
	ASME	Standard	ASME B 16.5 Class 600, B22-20 JIS/KS 30 and JIS/KS 40
Butt-weld	ASME B 16.25 Schedule 40 and Schedule 80		
Socket weld	ASME B 16.11		
Facing	Standard		Raised face Other facing is available on request.
Flanged face-to-face	EN	Standard	EN 558 Series 2.
	ASME	Standard	ISA-S75-03.

Materials

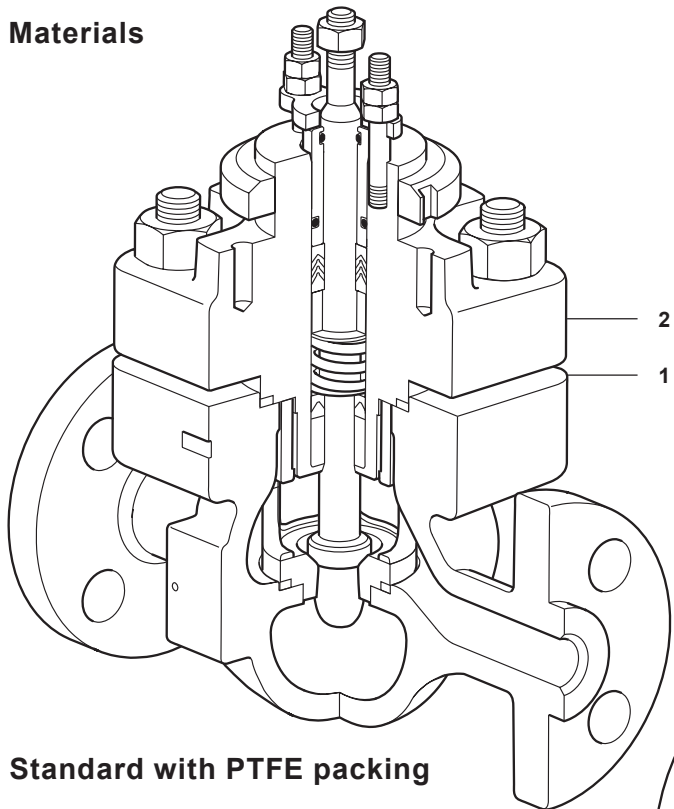

Standard with PTFE packing

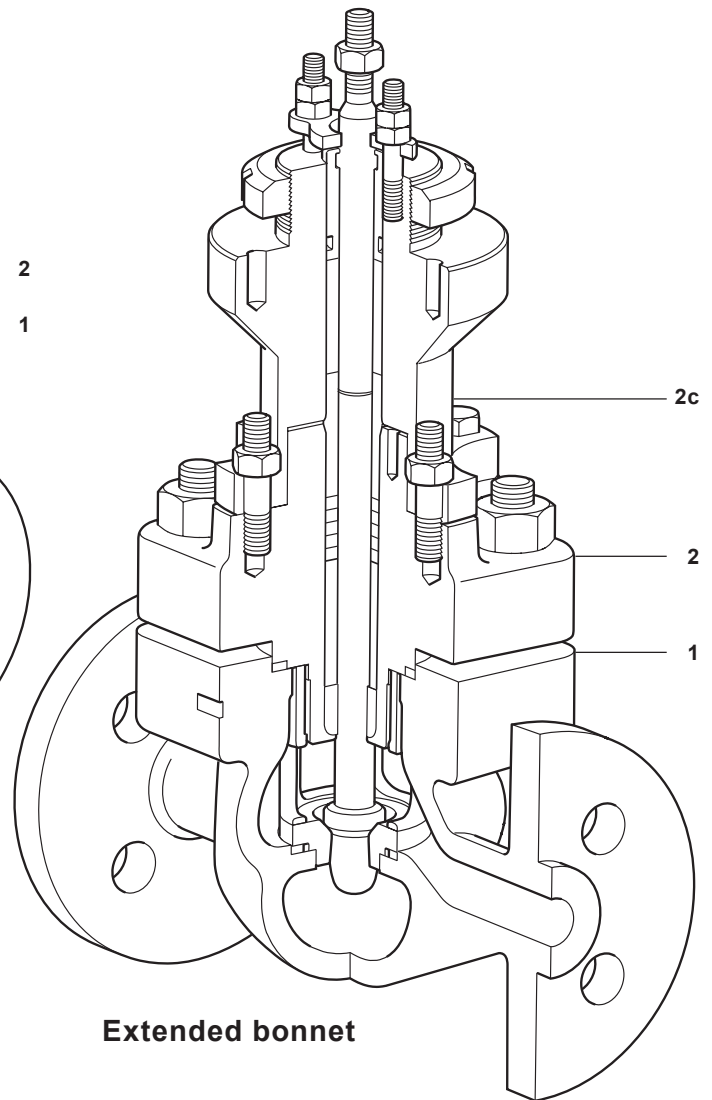

Extended bonnet

Type	No.	Part	Material	
JE and JEA	1	Body	JE43	Carbon steel EN 10213 1.0619+N
			JEA43	Carbon steel ASTM A216 WCB
			JE63	Stainless steel EN 10213 1.4408
			JEA63	Stainless steel ASTM A351 CF8M
			JE83	Alloy steel EN 10213 1.7357
			JEA83	Alloy steel ASTM A217 WC6
	2	Cover	JE43	Carbon steel EN 10213 1.0619+N
			JEA43	Carbon steel ASTM A216 WCB
			JE63	Stainless steel EN 10213 1.4408
			JEA63	Stainless steel ASTM A351 CF8M
			JE83	Alloy steel EN 10213 1.7357
			JEA83	Alloy steel ASTM A217 WC6
	2c	Extended bonnet	JE43 and JEA43	Carbon steel A105
			JE63 and JEA63	Stainless steel A316L
			JE83 and JEA83	Stainless steel A316L

Materials

Type	No.	Part	Material	
All versions using PTFE seals	3	Stem lock-nut	Stainless steel AISI 316	
	4	Bonnet gasket	Graphite/stainless steel	
	5	Seat retainer	Stainless steel with the exception of the full peek option	
	6	Valve seat ring	Seating version T	Stainless steel AISI 431 S29
			Seating versions P and K	PEEK
			Seating version W	Stainless Steel 316L + Stellite 6
			All others	Stainless steel 316L
	7	Seat gasket	Graphite/stainless steel	
	8	Valve plug and stem	Body stainless steel	Stainless steel with the exception of the Nitronic bush option
			All others	Stainless steel 431
	9 *	Lower stem guide	DN15 - DN100 (½" - 4")	PTFE
			DN125 - DN200 (5" - 8")	Stellite 6
	10	Lower stem wiper	DN15 - DN100 (½" - 4")	PTFE
	11	Packing guard washer	Stainless steel	AISI 316L
	12	Spring	Stainless steel	BS 2056 316 S42
	13 *	Packing spacer	Stainless steel	AISI 316
	14 *	Chevron packing set	PTFE	
	15	Outer 'O' ring	Viton	
	16	Inner 'O' ring	Viton	
	17 *	Gland flange	Stainless steel	AISI 304
	18 *	Gland follower	Stainless steel	
	19	Gland nut	Stainless steel	A2-70
	20	Gland stud	Stainless steel	
21	Actuator clamp nut	Plated carbon steel		
22	Bonnet nut	JE43 and JEA43	Carbon steel Grade 2H	
		JE63 and JEA63	Stainless steel Grade 8M	
		JE83 and JEA83	Alloy steel Grade 7	
23	Bonnet stud	JE43 and JEA43	Carbon steel Grade B7	
		JE63 and JEA63	Stainless steel Grade B8M2	
		JE83 and JEA83	Alloy steel Grade B16	

* Graphite packing

Type	No.	Part	Material
High temperature packing	9	Lower stem guide	Stellite 6
	13	Packing spacer	Stainless steel
	14	Graphoil packing	Graphite ring
	18	Gland follower	Stainless steel
	11	Not used	
	12	Not used	

* Graphite packing

Type	No.	Part	Material
High temperature packing	15	Not used	
	16	Not used	
	24	Extension gasket (only used with part 2c)	Graphite
	25	Extension bolting (only used with part 2c)	Stainless steel

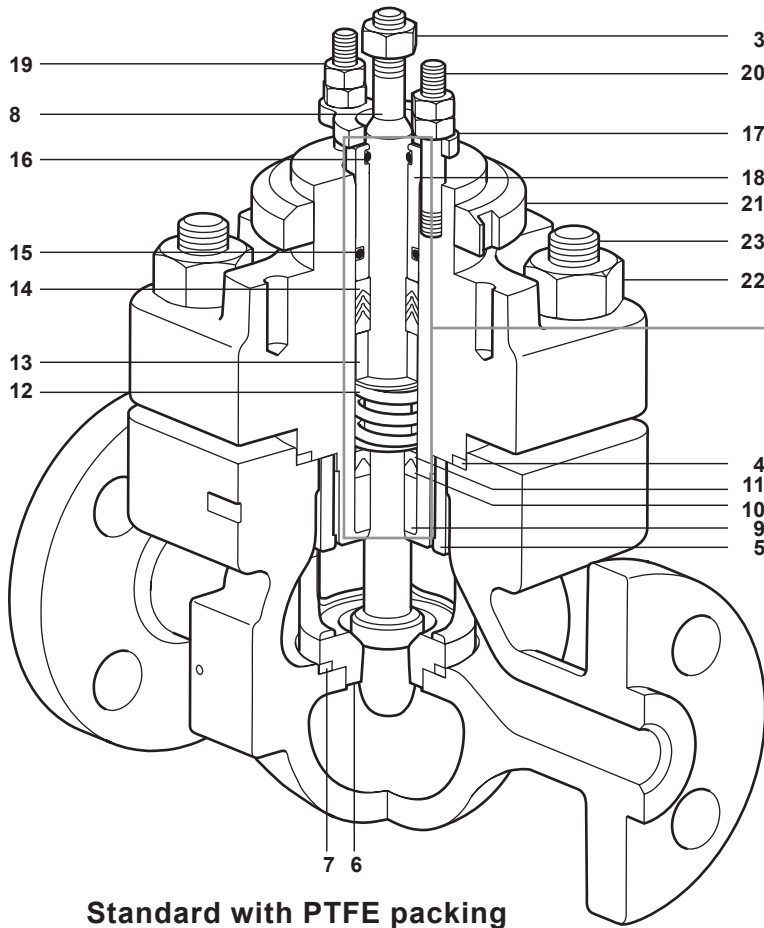

Standard with PTFE packing

Optional
graphite
packing

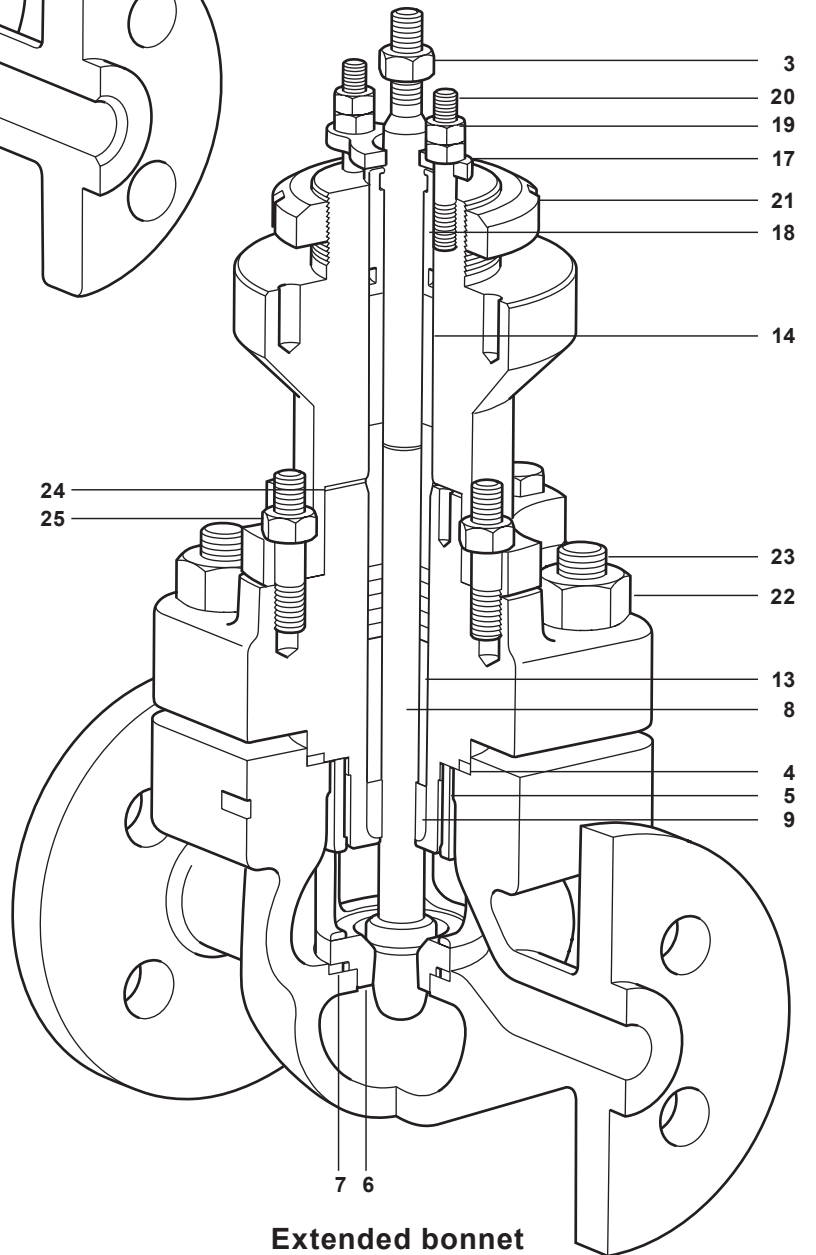
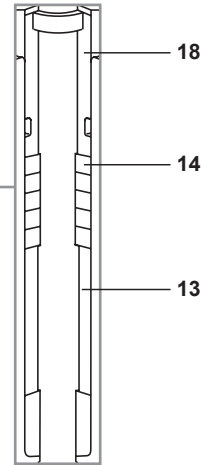

Extended bonnet

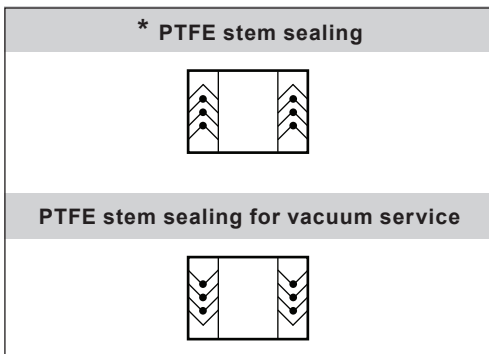



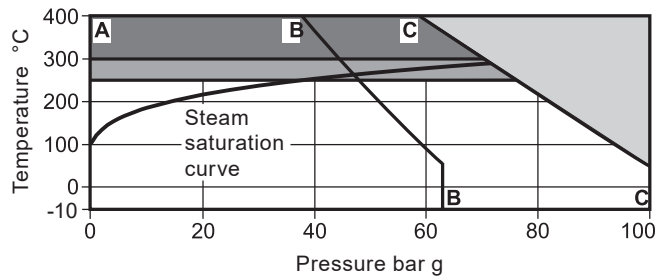

Pressure/temperature limits - JE43 and JEA43

**PN63
PN100**

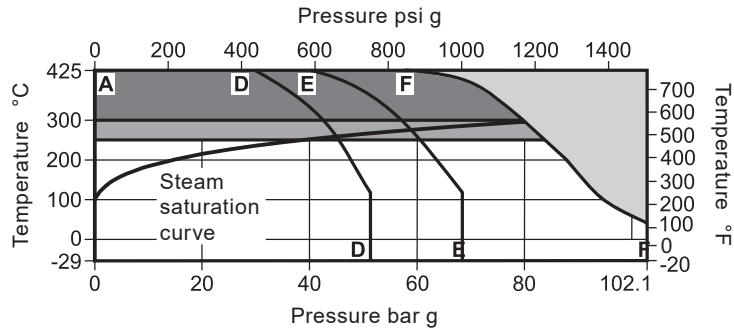

**ASME 600
JIS/KS 30
JIS/KS 40
Butt-weld
Socket weld**



-  The product **must not** be used in this region.
-  High temperature packing required for use on this region.
-  Extended cover is required for use in this region

Notes: 1. Where the process fluid temperature is sub-zero and the ambient temperature is below +5 °C (+41 °F), the external moving parts of the valve and actuator must be heat traced to maintain normal operation.

- A - B** Flanged EN 1092 PN63
- A - C** Flanged EN 1092 PN100
- A - D** Flanged JIS/KS 30
- A - E** Flanged JIS/KS 40
- A - F** Flanged ASME 600, Butt-weld and Socket weld

Body design conditions		PN100/ASME Class 600		
PMA and PMO	Maximum allowable pressure	EN	PN63 JE43 63 bar g @ 50 °C	
			PN100 JE43 100 bar g @ 50 °C	
	Maximum operating pressure	ASME 600, Butt-weld and Socket weld	JEA43	102.1 bar g @ 38 °C(1480 psi g @ 100 °F)
		JIS/KS 30	JEA43	51 bar g @ 120 °C
		JIS/KS 40	JEA43	68 bar g @ 120 °C
Maximum differential pressure design	PTFE soft seat (G)		7 bar	
	PEEK soft seat (K)		7 bar	
	Full PEEK seat (P)		19 bar	
TMA	Maximum allowable temperature	EN	JE43 400 °C	
		ASME 600, Butt-weld and Socket weld	JEA43 425 °C (797 °F)	
		JIS/KS 30	JEA43 425 °C	
		JIS/KS 40	JEA43 425 °C	
Minimum allowable temperature			-29 °C (-20 °F)	
TMO	Maximum operating temperature (For clarification of the options G, H, K and P see the Spira-trol™ selection guide on page 9)	Standard packing PTFE chevron	(Stem sealing - Options P and N) 250 °C	
		High temperature packing	(Stem sealing - Option H) 425 °C	
		Extended bonnet (E) with PTFE chevron	250 °C	
		Extended bonnet (E) with graphite packing	425 °C	
		PTFE soft seat	(Seating - Option G) 200 °C	
		PEEK soft seat	(Seating - Options K and P) 250 °C	
Minimum operating temperature		Note: For lower operating temperatures consult Spirax Sarco.	-29 °C (-20 °F)	
Designed for a maximum cold hydraulic test pressure of:			156 bar g (2 262 psi g)	

Pressure/temperature limits - JE63 and JEA63

**PN63
PN100**

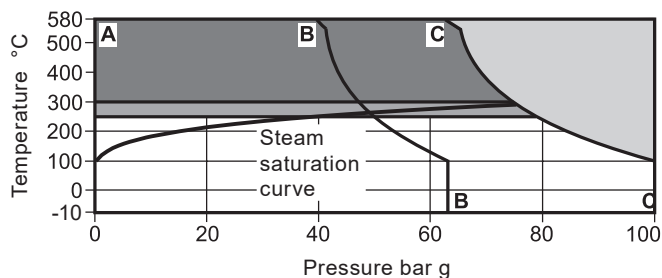

**JIS/KS 30
JIS/KS 40**

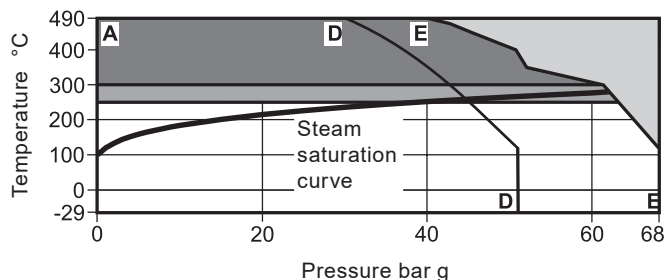

**ASME 600
Butt-weld
Socket weld**

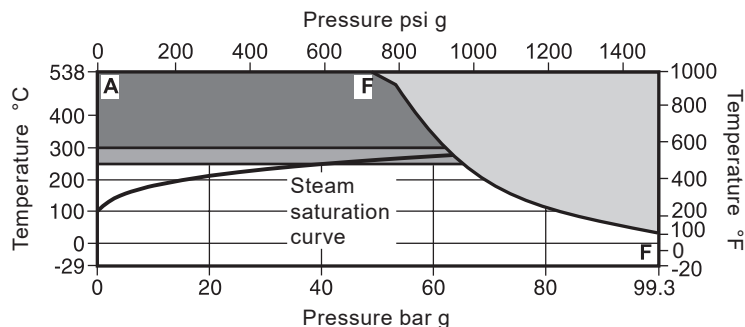

- The product **must not** be used in this region.
- High temperature packing required for use on this region.
- Extended cover is required for use in this region

Notes: 1. Where the process fluid temperature is sub-zero and the ambient temperature is below +5 °C (+41 °F), the external moving parts of the valve and actuator must be heat traced to maintain normal operation.

- A - B** Flanged EN 1092 PN63
- A - C** Flanged EN 1092 PN100
- A - D** Flanged JIS/KS 30
- A - E** Flanged JIS/KS 40
- A - F** Flanged ASME 600, Butt-weld and Socket weld

Body design conditions		PN100/ASME Class 600		
	EN	PN63	JE63	63 bar g @ 100 °C
		PN100	JE63	100 bar g @ 100 °C
PMA and PMO	Maximum allowable pressure and Maximum operating pressure	ASME 600, Butt-weld and Socket weld	JEA63	99.3 bar g @ 38 °C (1440 psi g @ 100 °F)
		JIS/KS 30	JEA63	51 bar g @ 120 °C
		JIS/KS 40	JEA63	68 bar g @ 120 °C
Maximum differential pressure design		PTFE soft seat (G)		7 bar
		PEEK soft seat (K)		7 bar
		Full PEEK seat (P)		19 bar
TMA	Maximum allowable temperature	EN	JE63	580 °C
		ASME 600, Butt-weld and Socket weld	JEA63	538 °C (1000 °F)
		JIS/KS 30	JEA63	490 °C
		JIS/KS 40	JEA63	490 °C
Minimum allowable temperature				-29 °C (-20 °F)
TMO	Maximum operating temperature (For clarification of the options G, H, K and P see the Spira-trol™ selection guide on page 9)	Standard packing PTFE chevron	(Stem sealing - Options P and N)	250 °C
		High temperature packing	(Stem sealing - Option H)	580 °C
		Extended bonnet (E) with PTFE chevron		250 °C
		Extended bonnet (E) with graphite packing		580 °C
		PTFE soft seat	(Seating - Option G)	200 °C
		PEEK soft seat	(Seating - Options K and P)	250 °C
Minimum operating temperature		Note: For lower operating temperatures consult SpiraxSarco.		-29 °C (-20 °F)
Designed for a maximum cold hydraulic test pressure of:				156 bar g (2262 psi g)

Pressure/temperature limits - JE83/JEA83

**PN63
PN100**

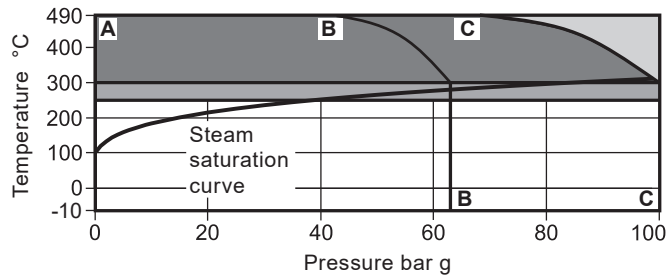



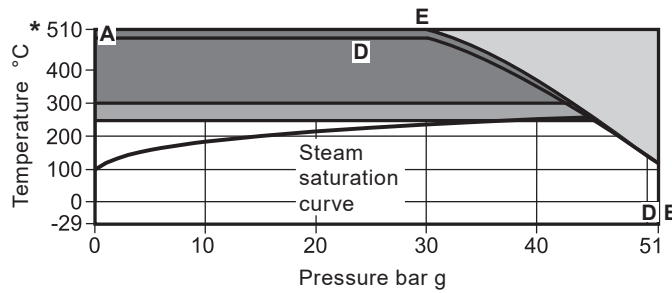

**JIS/KS 30
JIS/KS 40**

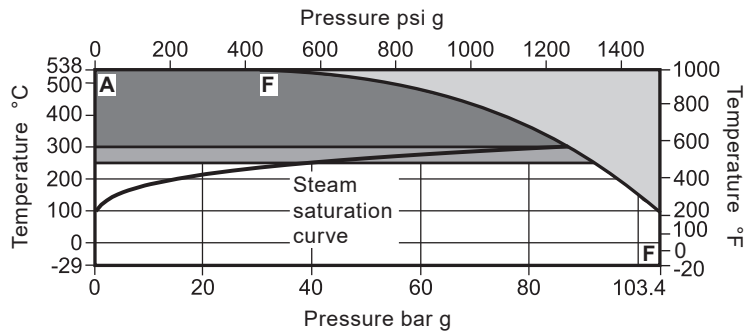

* JIS/KS 40 only

**ASME 600
Butt-weld
Socket weld**



-  The product **must not** be used in this region.
-  High temperature packing required for use on this region.
-  Extended cover is required for use in this region

Notes: 1. Where the process fluid temperature is sub-zero and the ambient temperature is below +5 °C (+41 °F), the external moving parts of the valve and actuator must be heat traced to maintain normal operation.

- A - B** Flanged EN 1092 PN63
- A - C** Flanged EN 1092 PN100
- A - D** Flanged JIS/KS 30
- A - E** Flanged JIS/KS 40
- A - F** Flanged ASME 600, Butt-weld and Socket weld

Body design conditions		PN100/ASME Class 600		
PMA and PMO	Maximum allowable pressure	EN PN63	JE83	63 bar g @ 300 °C
		PN100	JE83	100 bar g @ 300 °C
	Maximum operating pressure	ASME 600, Butt-weld and Socket weld		JEA83 103.4 bar g @ 38 °C (1499 psi g @ 100 °F)
		JIS/KS 30	JEA83	51 bar g @ 120 °C
		JIS/KS 40	JEA83	68 bar g @ 120 °C
Maximum differential pressure design	PTFE soft seat (G)		7 bar	
	PEEK soft seat (K)		7 bar	
	Full PEEK seat (P)		19 bar	
TMA	Maximum allowable temperature	EN	JE83	490 °C
		ASME 600, Butt-weld and Socket weld		JEA83 538 °C (1000 °F)
		JIS/KS 30	JEA83	490 °C
		JIS/KS 40	JEA83	510 °C
Minimum allowable temperature		-29 °C (-20 °F)		
TMO	Maximum operating temperature (For clarification of the options G, H, K and P see the Spira-trol™ selection guide on page 9)	Standard packing PTFE chevron	(Stem sealing - Options P and N)	250 °C
		High temperature packing	(Stem sealing - Option H)	538 °C
		Extended bonnet (E) with PTFE chevron		250 °C
		Extended bonnet (E) with graphite packing		538 °C
		PTFE soft seat	(Seating - Option G)	200 °C
		PEEK soft seat	(Seating - Options K and P)	250 °C
Minimum operating temperature		Note: For lower operating temperatures consult SpiraxSarco.	-29 °C (-20 °F)	
Designed for a maximum cold hydraulic test pressure of:		156 bar g (2262 psi g)		

K_v values

Valve size			DN15	DN20	DN25	DN32	DN40	DN50	DN65	DN80	DN100	DN125	DN150	DN200
Standard trim	High capacity	Equal %	4.9	7.2	11.0	17.5	31.0	46.0	90	115	N/A	N/A	N/A	N/A
	Full port	Equal %	4.0	6.3	10.0	16.0	25.0	36.0	63.0	100	160	245	370	580
		Linear	4.0	6.3	10.0	16.0	25.0	36.0	63.0	100	160	260	390	640
		Fast opening	4.0	6.3	10.0	18.0	28.0	50.0	85.0	117	180	260	390	640
	Reduced trim 1	Equal %	2.5	4.0	6.3	10.0	16.0	25.0	36.0	63	100	200	287	370
		Linear	2.5	4.0	6.3	10.0	16.0	25.0	36.0	63	100	200	287	550
	Reduced trim 2	Equal %	1.6	2.5	4.0	6.3	10.0	16.0	25.0	36	63	100	154	232
		Linear	1.6	2.5	4.0	6.3	10.0	16.0	25.0	36	63	100	154	232
	Reduced trim 3	Equal %	1.0	1.6	2.5	4.0	6.3	10.0	16.0	25	36	63	103	163
		Linear	1.0	1.6	2.5	4.0	6.3	10.0	16.0	25	36	63	103	163
	Reduced trim 4	Equal %		1.0	1.6		4.0	6.3		16				
		Linear		1.0	1.6		4.0	6.3		16				
	Reduced trim 5	Equal %			1.0		4.0							
		Linear			1.0		4.0							
Microflute			0.5	0.5	0.5									
			0.2	0.2	0.2									
			0.1	0.1	0.1									
			0.07	0.07	0.07									
			0.01	0.01	0.01									

Note: See TI-S24-59 for low noise and anti-cavitation trims. Special K_v values are available on request.

C_v (US) values

Valve size			DN15	DN20	DN25	DN32	DN40	DN50	DN65	DN80	DN100	DN125	DN150	DN200
Standard trim	High capacity	Equal %	5.7	8.3	12.7	20.2	36.0	53.0	104.0	133.0	N/A	N/A	N/A	N/A
	Full port	Equal %	4.6	7.3	12.0	18.0	29.0	42.0	73.0	116.0	185.0	283	433	679
		Linear	4.6	7.3	12.0	18.0	29.0	42.0	73.0	116.0	185.0	300	456	749
		Fast opening	4.6	7.3	12.0	21.0	32.0	58.0	98.0	135.0	208.0	300	456	749
	Reduced trim 1	Equal %	2.9	4.6	7.3	12.0	18.0	29.0	42.0	73.0	116.0	231	336	433
		Linear	2.9	4.6	7.3	12.0	18.0	29.0	42.0	73.0	116.0	231	336	635
	Reduced trim 2	Equal %	1.8	2.9	4.6	7.3	12.0	18.0	29.0	42.0	73.0	120	154	271
		Linear	1.8	2.9	4.6	7.3	12.0	18.0	29.0	42.0	73.0	120	154	271
	Reduced trim 3	Equal %	1.2	1.8	2.9	4.6	7.3	12.0	18.0	29.0	42.0	75	154	191
		Linear	1.2	1.8	2.9	4.6	7.3	12.0	18.0	29.0	42.0	75	154	191
	Reduced trim 4	Equal %		1.2	1.8		4.6	7.3		18.0				
		Linear		1.2	1.8		4.6	7.3		18.0				
	Reduced trim 5	Equal %			1.2		4.6							
		Linear			1.2		4.6							
Microflute			0.58	0.58	0.6									
			0.23	0.23	0.23									
			0.12	0.12	0.12									
			0.081	0.081	0.081									
			0.012	0.012	0.012									

Note: See TI-S24-59 for low noise and anti-cavitation trims. Special C_v values are available on request.

Dimensions/weights (approximate) in mm and kg

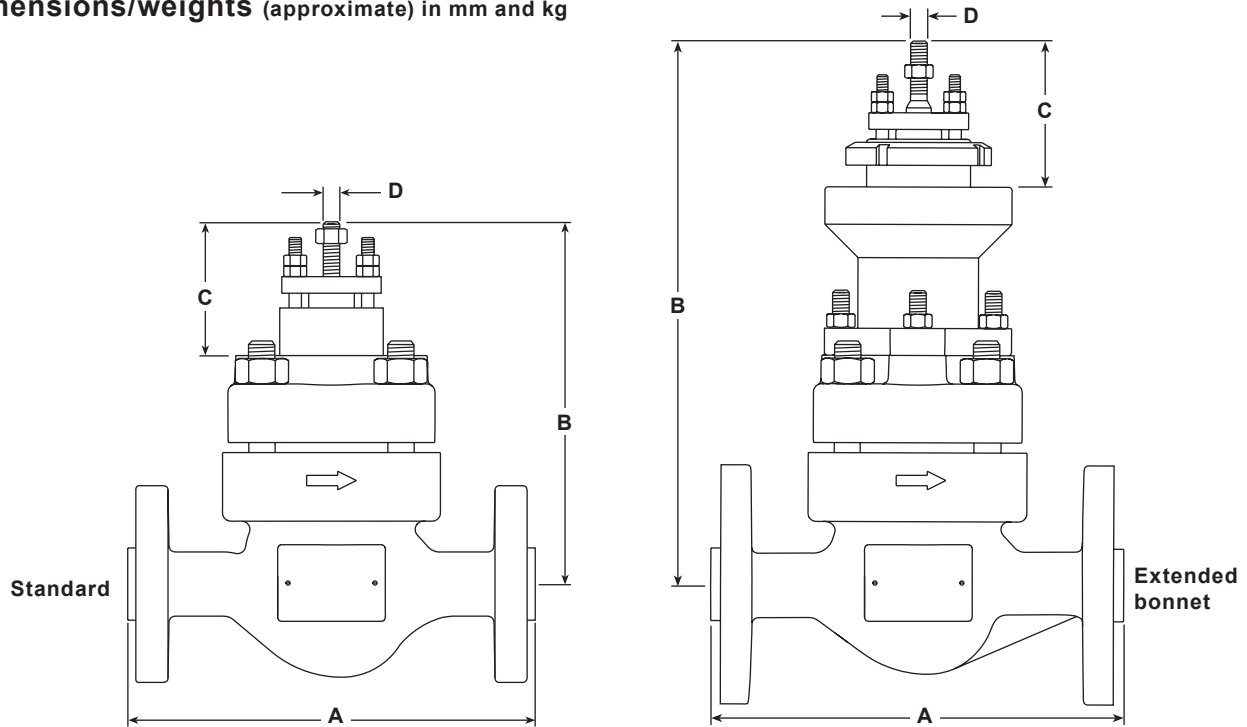

Size	Dimensions						Weights			
	A		Standard	B		C	D	ASME 600	PN100	Butt-weld Socket weld
	ASME 600 JIS/KS 30 JIS/KS 40 Butt-weld Socket weld	EN 1092 PN63 PN100		Carbon steel	Stainless steel Alloy steel					
DN15	203	210	172	261	321	64	M8	9.5	10	6
DN20	206	230	172	261	321	64	M8	10.2	12	6
DN25	210	230	172	261	321	64	M8	10.8	13	6
DN32	251	260	201	278	338	69	M8	16.5	19	11
DN40	251	260	201	278	338	69	M8	18.5	22	11
DN50	286	300	196	278	338	69	M8	22.0	27	13
DN65	311	340	282	470	587	81	M12	46.5	51	31
DN80	337	380	282	470	587	81	M12	51.5	58	35
DN100	394	430	297	513	605	81	M12	83.0	79	46
DN125	457	500	382	663	783	125	M30	133.0	124	74
DN150	508	550	400	681	801	125	M30	176.0	168	108
DN200	610	650	466	747	867	125	M30	300.0	306	197

Spare parts

Spira-trol™

The spare parts available are shown in solid outline. Parts drawn in a grey line are not supplied as spares.

Note: When placing an order for spare parts please specify clearly the full product description as found on the label of the valve body, as this will ensure that the correct spare parts are supplied.

Available spares – JE and JEA

Actuator clamping nut		A
Gasket set		B, G
Stem seal kits	PTFE packing	C
	Graphite packing	C1
	Graphite seal set	C2
Plug stem and seat kit	Equal percentage trim (No gaskets supplied)	D, E
	Fast opening trim (No gaskets supplied)	D1, E
	Linear trim (No gaskets supplied)	D2, E
Soft seat arrangement		H

How to order spares

Always order spares by using the description given in the column headed 'Available spares', and state the size and type of valve including the full product description of the product.

Example: 1 - Plug stem and seat kit for a Spirax Sarco DN32 Spira-trol™ JE43PTSUSS.2 Kv 16 two-port control valve having flanged PN63 connections.

How to fit spares

Full fitting instructions are given in the Installation and Maintenance Instructions supplied with the spare.

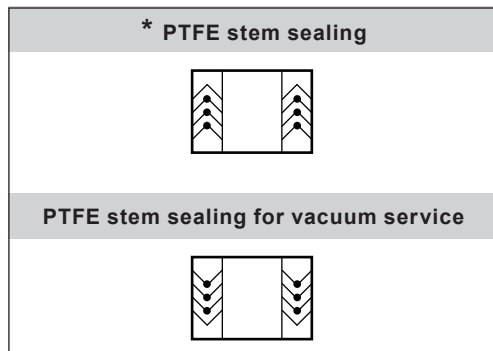
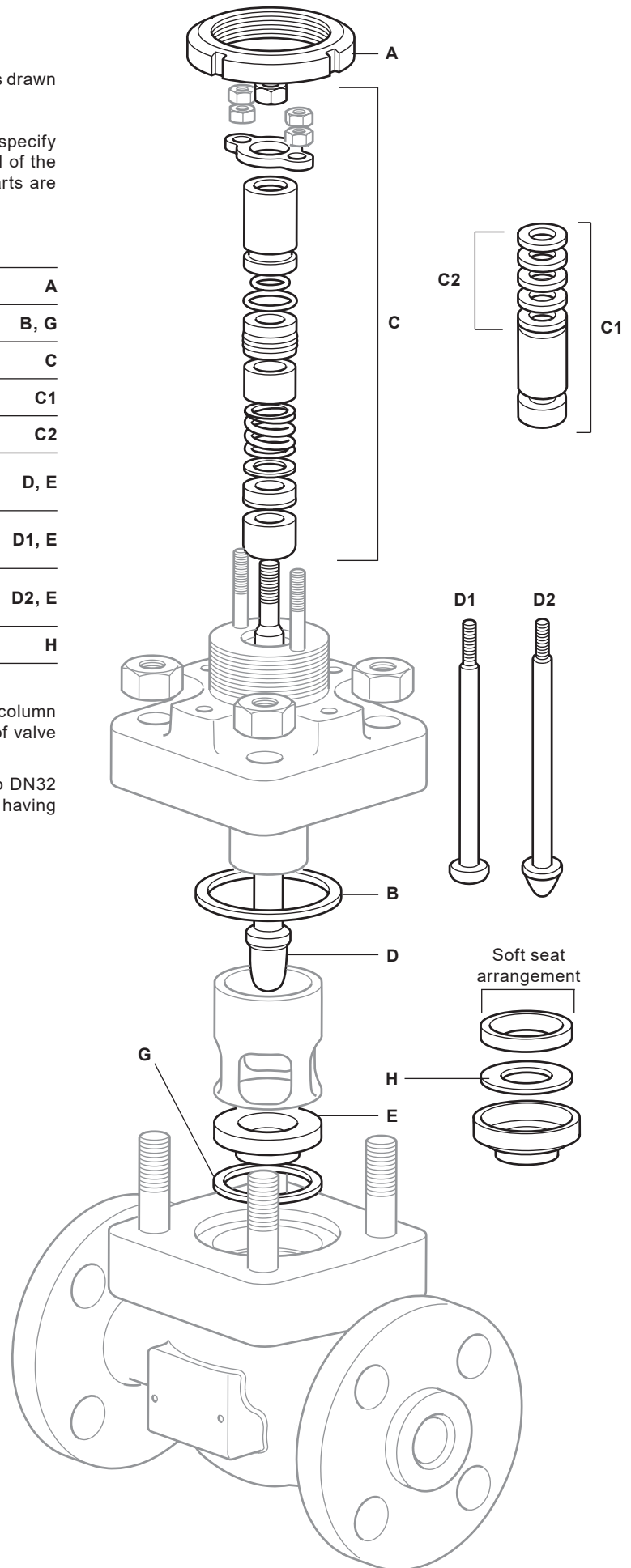

Spira-trol™ selection guide:

Valve size	EN standard = DN15, DN20, DN25, DN32, DN40, DN50, DN65*, DN80, DN100, DN125, DN150, DN200	DN25
	ASME standard = ½", ¾", 1", 1¼", 1½", 2", 2½", 3", 4", 5", 6" and 8"	
Valve series	J = J series 2-port control valve	J
Valve characteristic	E = Equal percentage F = Fast opening L = Linear	E
Flange type	Blank = EN (PN) A = ASME	Blank
Flow	Blank = under T = over	Blank
Body material	4 = Carbon steel 6 = Stainless steel 8 = Alloy steel	4
Connections	1 = Screwed 2 = Socket weld 3 = Flanged 4 = Butt weld	3
Stem sealing	H = Graphite N = PTFE and Nitronic bearing (Available for DN15 to DN50 size range only) P = PTFE V = PTFE for Vacuum	P
Seating	G = PTFE soft seat K = PEEK soft seat P = Full PEEK S = 316L stainless steel (Available for DN15 to DN100 size range only) T = 431 stainless steel W = 316L with stellite 6 facing	T
Type of trim	A1 = 1 stage anti-cavitation A2 = 2 stage anti-cavitation P1 = 1 stage low noise trim P2 = 2 stage low noise trim P3 = 3 stage low noise trim S = Standard trim	S
Trim balancing	B = Balanced U = Unbalanced	U
Bonnet type	E = Extended S = Standard	S
Bolting	S = Standard	S
Series	2 = .2	0.2
Kvs	To be specified	Kv 10
Connection type	To be specified	Flanged PN63

* **Please note:** The PN63 flanges for the JE43 sizes have 4 bolt holes as standard; 8 bolt holes are available on request.

Selection example:

DN32	-	J	E	4	3	P	T	S	U	S	S	.2	-	Kv 16	-	Flanged PN63
------	---	---	---	---	---	---	---	---	---	---	---	----	---	-------	---	--------------

How to order

Example: 1 off Spirax Sarco Spira-trol™ DN32 JE43PTSUSS.2 Kv 16 two-port control valve having flanged PN63 connections.