



Cert. No. LRQ 0963008

ISO 9001

SIB30 and SIB30H Sealed Inverted Bucket Steam Traps

Description

The SIB30 and SIB30H are all stainless steel sealed inverted bucket steam traps.

Sizes and pipe connections

½" and ¾" screwed BSP or NPT.
DN15 and DN20 socket weld ends (BS 3799)
DN15 and DN20 standard flange ANSI 150 and 300, BS 4504 PN40.
Flanges also available JIS tables 20, 16 and 10.

Limiting conditions (ISO 6552)

Body design conditions	PN50
PMA - Maximum allowable pressure	50 bar g
TMA - Maximum allowable temperature	400°C
PMO - Maximum operating pressure for saturated steam service	30 bar g
TMO - Maximum operating temperature	400°C
Designed for a maximum cold hydraulic test pressure of 75 bar g	

Operating range

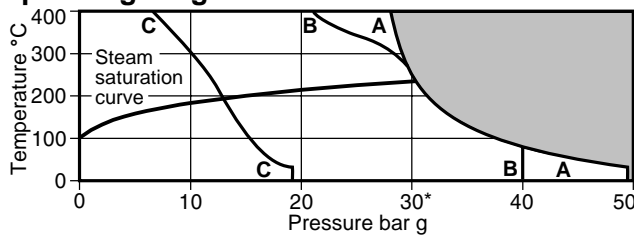

The product **must not** be used in this region.

*PMO Maximum operating pressure recommended.

A - A Flanged ANSI 300, screwed and socket weld.

B - B Flanged BS 4504 PN40.

C - C Flanged ANSI 150.

ΔPMX - Maximum differential pressure limitations bar

ΔPMX	Trap	
30.0	SIB30/4	SIB30H/5
20.0	SIB30/5	SIB30H/6
12.0	SIB30/6	SIB30H/7
8.5	SIB30/7	SIB30H/8
5.0	SIB30H/10	
4.0	SIB30/8	
2.5	SIB30/10	
2.0	SIB30H/12	
1.5	SIB30/12	

Materials

No.	Part	Material
1	Cover	Stainless steel ASTM A240 Gr. 304
2	Body	Stainless steel ASTM A314 Gr. 304
	Flanges	Carbon steel Mat No. 1.0460 (C22.8)
3	Bucket	Stainless steel BS 1449 321 S 12
4	Pivot pin	Stainless steel BS 970 304 S 15
5	Valve seat	Stainless steel AISI 440B
6	Valve	Stainless steel AISI 440B
7	Valve lever	Stainless steel BS 1449 321 S 12
8	Internal tube	Stainless steel BS 3605 304 S 14

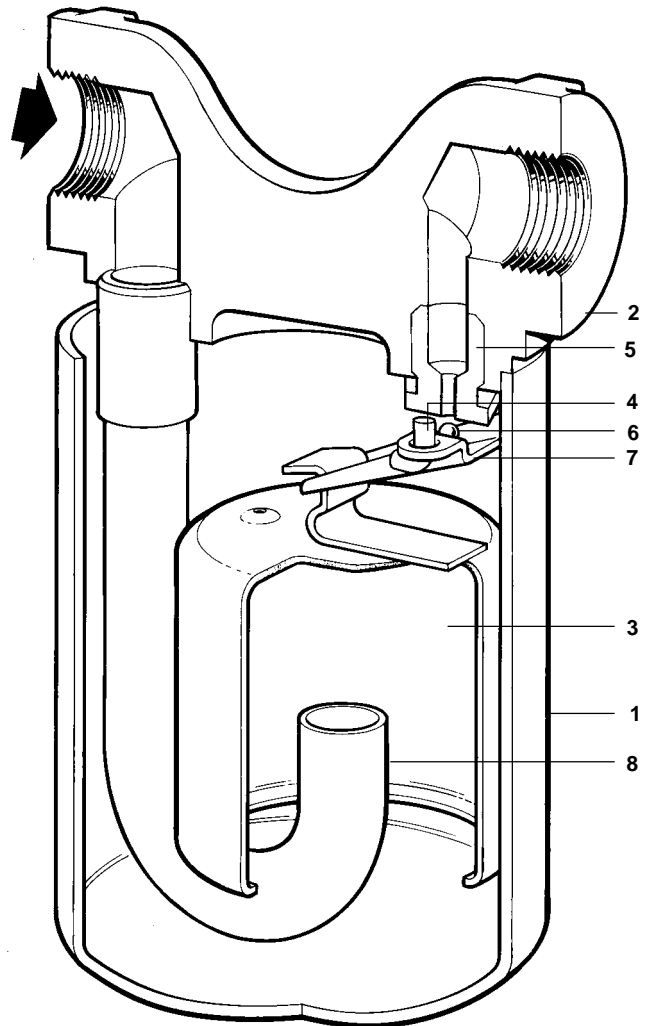

Dimensions/weights (approximate) in mm and kg

SIB30 Size	A	A1	B	C	D	Scr /SW	Weight Fig
DN15 - 1/2"	110	150	76	124	143	1.5	2.9
DN20 - 3/4"	110	150	76	124	143	1.5	2.9

SIB30H Size	A	A1	B	C	D	Scr /SW	Weight Fig
DN15 - 1/2"	110	150	76	159	177	1.75	3.15
DN20 - 3/4"	110	150	76	159	177	1.75	3.15

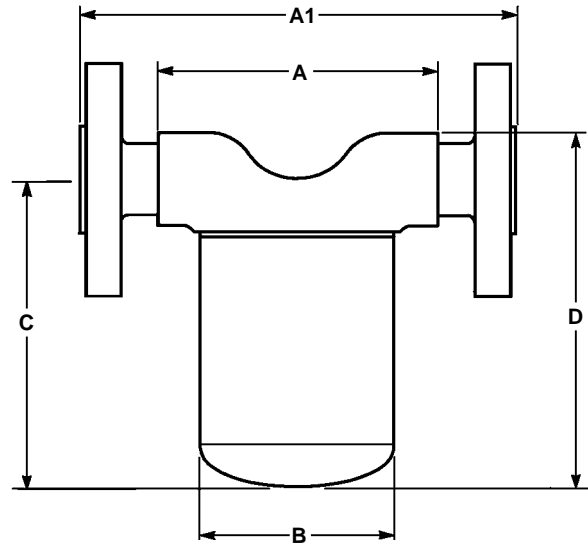

Safety information, installation and maintenance

For full details see the Installation and Maintenance Instructions (IM-P110-05) supplied with the product.

Installation note:

Install in a horizontal pipe, below the drain point. If installed in exposed positions, consideration should be given to insulating the trap.

How to order

Example: 1 off Spirax Sarco 1/2" screwed BSP SIB30/6 sealed inverted bucket steam trap.

Note: The cover (and flanges when specified) are welded to the body using the TIG process. Welds are approved in accordance with ASME section IX and BS EN 288.

Capacities

Note: A trap should be selected for the most appropriate working pressure differential and not on the basis of load, e.g. 80 kg/h at 7 bar differential should be handled with the SIB30/7 and not the SIB30/4.

