



## SGC40 and SGS40 Sight Glasses

### Description

The SGC40 cast carbon steel and SGS40 stainless steel are double window sight glasses having screwed, sanitary clamp, socket weld and flanged connections.

**DN32 shown** having an integral flange  
**Please note** that flanges are welded onto the body of the smaller DN15 to DN25 units.

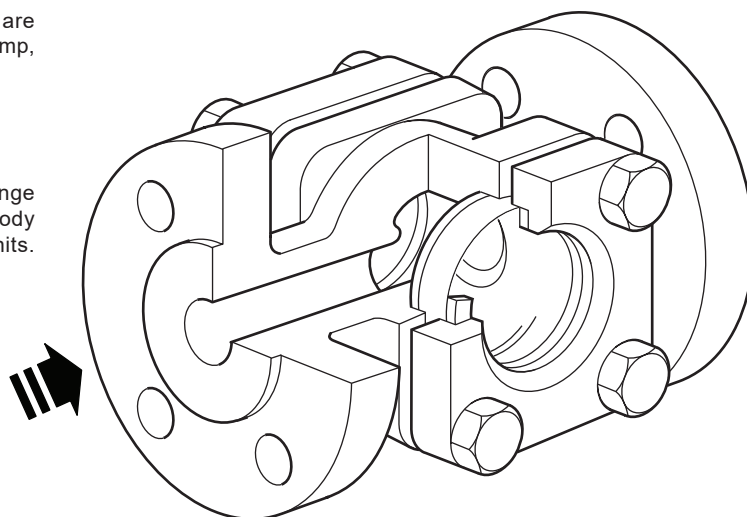

### Standards

These products fully comply with the requirements of the European Pressure Equipment Directive 2014/68/EU and carry the **CE** mark when so required.

### Certification

These products are available with a manufacturer's Typical Test Report and if specified certification to EN 10204 3.1.  
**Note:** All certification/inspection requirements must be stated at the time of order placement.

### Optional extras:

- Visual flow indicator flap to check the flow of the liquid in the pipeline.
- Spring: The visual flow indicator flap can be spring loaded for applications on vertical lines or where there is high flowrates.
- Mica glass protectors for severe applications - When these have been specified the nomenclature becomes SGC40M and SGS40M.
- Glass filled PTFE gasket.

Please see table below to identify when Mica glass protectors are to be used.

Application	Glass choice to be used
Steam or > pH9	Mica glass protectors and Borosilicate glass windows
>150 °C and > pH7	Mica glass protectors and Borosilicate glass windows
<150 °C and < pH7	Borosilicate glass windows only

### Sizes and pipe connections

- 1/2", 3/4", 1", 1 1/4", 1 1/2" and 2" Screwed BSP T Rp (ISO 7-1), NPT and Socket weld.
- DN15, DN20, DN25, DN40 and DN50 Sanitary clamp connections to ASME BPE.
- DN15, DN20, DN25, DN32, DN40, DN50, DN65, DN80 and DN100.  
 Flanged EN 1092 PN40, ASME Class 150 and Class 300, JIS/KS 10 and JIS/KS 20.
- Flanged versions have face-to-face dimensions in accordance with EN 558 Series 1.

## Materials

**DN32 shown** having an integral flange  
**Please note** that flanges are welded onto the body of the smaller DN15 to DN25 units.

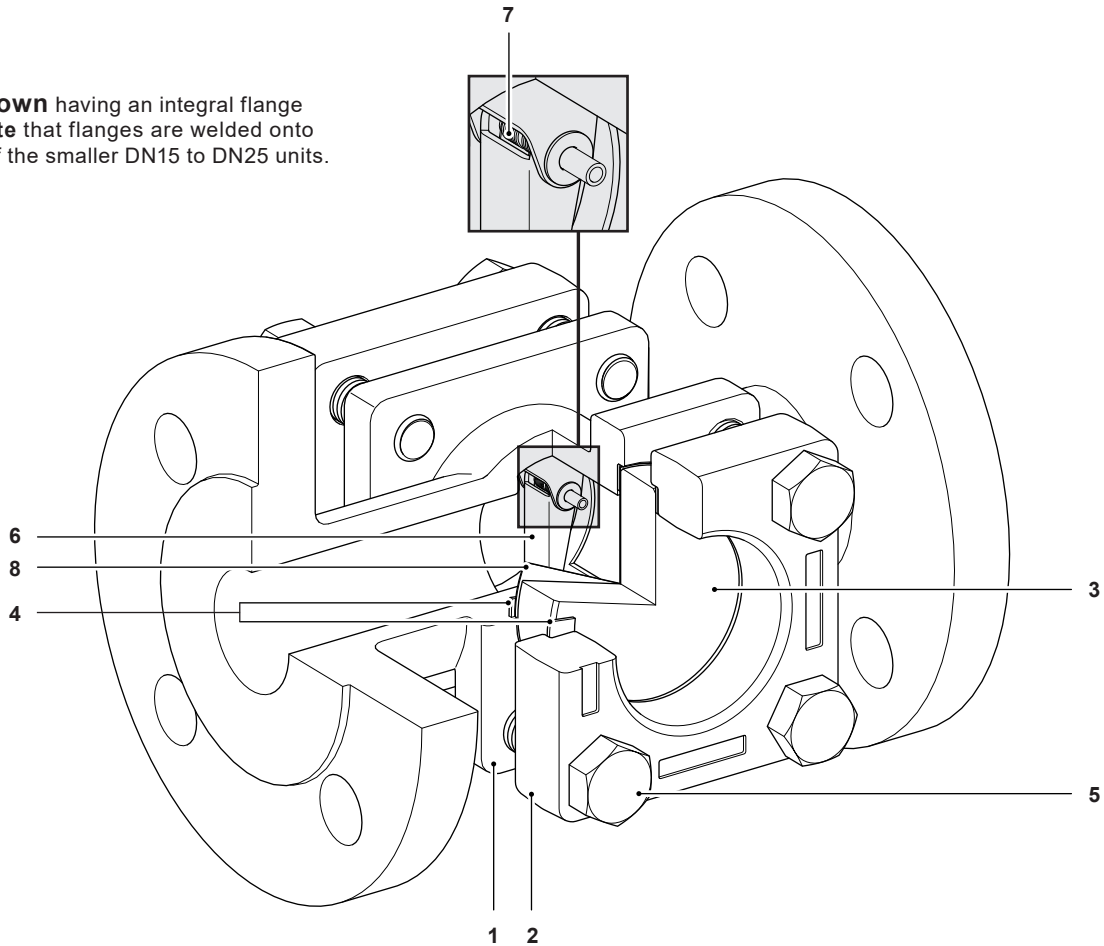

No. Part	Material		
1 Body*	<b>SGC40</b>	Carbon steel	EN 10213 1.0619+N/ASTM A216 WCB
	<b>SGS40</b>	Stainless steel	EN 10213 1.4308/ASTM A351-CF8
* The materials shown for the body are for all available connections and for the DN32 to DN100 integrally flanged units. <b>Please note</b> that flanges are welded onto the body of the smaller DN15 to DN25 units - See flange material below:			
* Flange material for sizes DN15 to DN25	<b>SGC40</b>	Carbon steel	C22.8 according EN 10222-2/A105N according ASTM A105
	<b>SGS40</b>	Stainless steel	1.4571 according EN 10222-5/316Ti according ASTM A182
2 Cover	<b>SGC40</b>	DN15 to DN50	Carbon steel C22.8 according EN 10222-2/A105N according ASTM A105
		DN65 to DN100	Carbon steel EN 10213 1.0619+N/ASTM A216 WCB
	<b>SGS40</b>	Stainless steel	EN 10213 1.4308/ASTM A351-CF8
3 Window	Borosilicate glass		DIN 7080
4 Gaskets	Reinforced exfoliated graphite (standard) or PTFE Glass filled (optional)		
5 Cover bolts	Stainless steel		EN ISO 3506-1 A2-70

## Materials - Optional extras

6 Visual flow indicator flap	Stainless steel
7 Spring	Stainless steel
8 Glass protectors	Mica

## Pressure/temperature limits - SGC40 Carbon steel

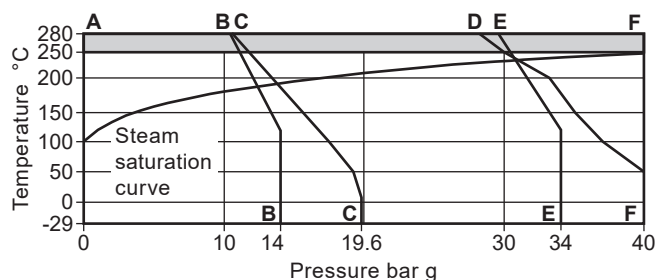

Only graphite gasket to be used on this region.

The product **must not** be used in this region.

**A-B-B** Flanged JIS 10 and KS 10.

**A-C-C** Flanged ASME 150.

**A-D-F** Flanged EN 1092 PN40.

**A-E-E** Flanged JIS 20 and KS 20.

**A-F-F** Screwed BSP T Rp (ISO 7-1) T Rp (ISO 7-1), NPT, Sanitary clamp, Socket weld and Flanged ASME 300.

Body design conditions		PN40	
		PN40	40 bar g @ 50 °C
		ASME 150	19.6 bar g @ 38 °C
PMA	Maximum allowable pressure	ASME 300	40 bar g @ 280 °C
		JIS/KS10	14 bar g @ 120 °C
		JIS/KS20	34 bar g @ 120 °C
TMA	Maximum allowable temperature	With PTFE gasket	250 °C
		With graphite gasket	280 °C
		PN40	31.1 bar g @ 238 °C
		ASME 150	13.8 bar g @ 198 °C
PMO	Maximum allowable pressure for saturated steam service	ASME 300	40 bar g @ 252 °C
		JIS/KS10	12.5 bar g @ 195 °C
		JIS/KS20	30.3 bar g @ 236 °C
TMO	Maximum operating temperature	With PTFE gasket	250 °C
		With graphite gasket	280 °C
Minimum operating temperature			-29 °C
<b>Note:</b> For lower operating temperatures consult Spirax Sarco			
Designed for a maximum cold hydraulic test pressure of:			60 bar g

## Pressure/temperature limits - SGS40 Stainless steel

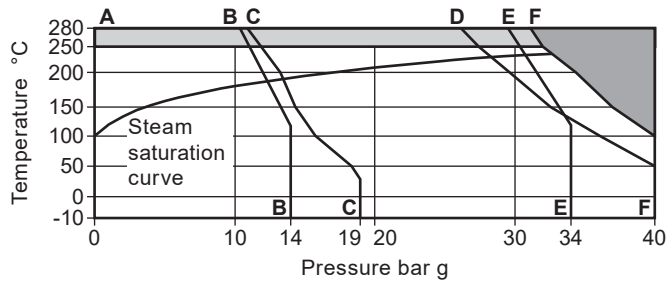

Only graphite gasket to be used on this region.

The product **must not** be used in this region.

**A-B-B** Flanged JIS 10 and KS 10.

**A-C-C** Flanged ASME 150.

**A-D-F** Flanged EN 1092 PN40.

**A-E-E** Flanged JIS 20 and KS 20.

**A-F-F** Screwed BSP T Rp (ISO 7-1), NPT, Sanitary clamp, Socket weld and Flanged ASME 300.

Body design conditions		PN40
		40 bar g @ 50 °C
		ASME 150
		19 bar g @ 38 °C
PMA Maximum allowable pressure		ASME 300
		40 bar g @ 111 °C
		JIS/KS10
		14 bar g @ 120 °C
		JIS/KS20
		34 bar g @ 120 °C
TMA Maximum allowable temperature		With PTFE gasket
		250 °C
		With graphite gasket
		280 °C
		PN40
		28.3 bar g @ 232 °C
		ASME 150
		12.9 bar g @ 195 °C
PMO Maximum allowable pressure for saturated steam service		ASME 300
		32.8 bar g @ 241 °C
		JIS/KS10
		12.5 bar g @ 195 °C
		JIS/KS20
		30.3 bar g @ 236 °C
TMO Maximum operating temperature		With PTFE gasket
		250 °C
		With graphite gasket
		280 °C
Minimum operating temperature		-10 °C
<b>Note:</b> For lower operating temperatures consult Spirax Sarco		
Designed for a maximum cold hydraulic test pressure of:		60 bar g

**Dimensions/weights (approximate) in mm and kg**

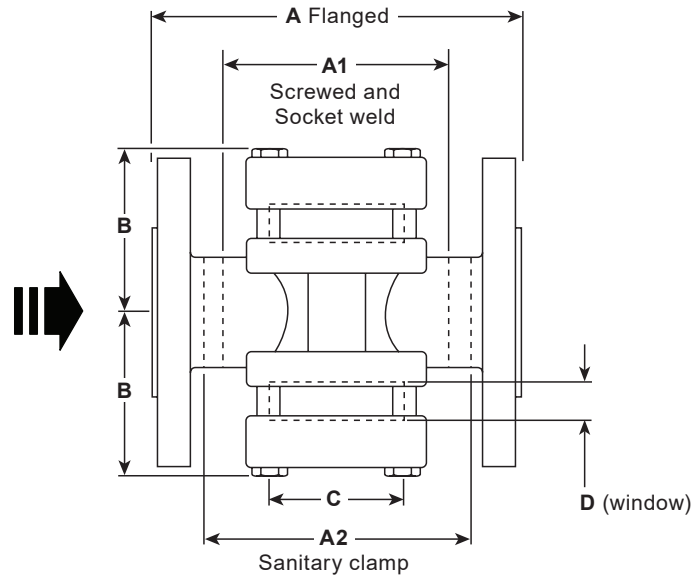

Size	Dimensions (mm)						Weight (kg)		
	A	A1	A2	B	C	D	Flanged	Screwed Socket weld	Sanitary clamp
DN15	130	95	120	48.5	46.7	10	3.5	2	2
DN20	150	95	140	51	46.7	10	4.3	2	2.2
DN25	160	95	155	68.5	60.8	15	6.4	3.5	4
DN32	-	150	-	91.5	71.4	15	-	7	-
DN32 flanged	180	-	-	72	60.8	15	7.8	-	-
DN40	-	150	202	91.5	71.4	20	-	6.75	7.4
DN40 flanged	200	-	-	86.5	71.4	20	10.5	-	-
DN50	230	150	232	91.5	71.4	20	12.5	6	7.6
DN65	290	-	-	126.5	113.2	30	27.7	-	-
DN80	310	-	-	134	113.2	30	31	-	-
DN100	350	-	-	143	113.2	30	37	-	-

## Safety information, installation and maintenance

For full details see the Installation and Maintenance Instructions (IM-P130-29) supplied with the product.

### Warning:

Under certain conditions corrosive elements in the flow media can affect the inside face of the window, particularly where caustic alkali and hydrofluoric acid are present. Mica glass protectors must be used to protect the glass when the unit is used on steam applications or when the pH is higher than pH9 or when the temperature is above 150 °C with a pH greater than pH7.

Regular inspection of the glass to check for thinning of the window must be undertaken based on an assessment of your system.

If there is evidence of thinning or erosion damage then the window should be replaced immediately. Always wear eye protection when viewing the contents of the sight glass.

Reasonable steps should be taken to protect personnel from injury in the unlikely event that the window breaks.

### Installation and maintenance note:

Apply the appropriate grease to SGS40 stainless steel connections and bolting to avoid cold welding.

Sight glasses should have stop valves fitted on both the inlet and outlet. It is imperative that the upstream stop valve is closed first in order to prevent overpressurisation.

Sight glasses must be fitted on the outlet side of a steam trap in either a horizontal or vertical pipeline in accordance with the flow arrow on the body. Warning: when the optional visual flow indicator flap is requested for horizontal flow applications the hinge must be placed uppermost otherwise it will not work for the purpose intended. Where the trap is a blast discharge type e.g. thermodynamic, the sight glass must be fitted at least 1 m from the trap. This is to ensure that the glass is not subjected to thermal shock or pressure.

Ensure access is available for maintenance purposes.

### Disposal

The product is recyclable. No ecological hazard is anticipated with disposal of this product providing due care is taken.

### How to order

**Example:** 1 off Spirax Sarco DN20 SGS40M sight glass having a stainless steel body, removable toughened glass windows and flanged EN 1092 PN40 connections.

The unit must be supplied complete with the optional 'visual flow indicator flap' and the 'Mica glass protectors'.

## Spare parts

The spare parts available are shown in solid outline.  
Parts drawn in a grey line are not supplied as spares.

### Available spares

Set of windows and gaskets	<b>3, 4</b>
Set of gaskets	<b>4</b>
Visual flow indicator flap	<b>6</b>
Mica glass protectors	<b>8</b>



### How to order spares

Always order spares by using the description given in the column headed 'Available spares' and state the size and type of the sight glass.

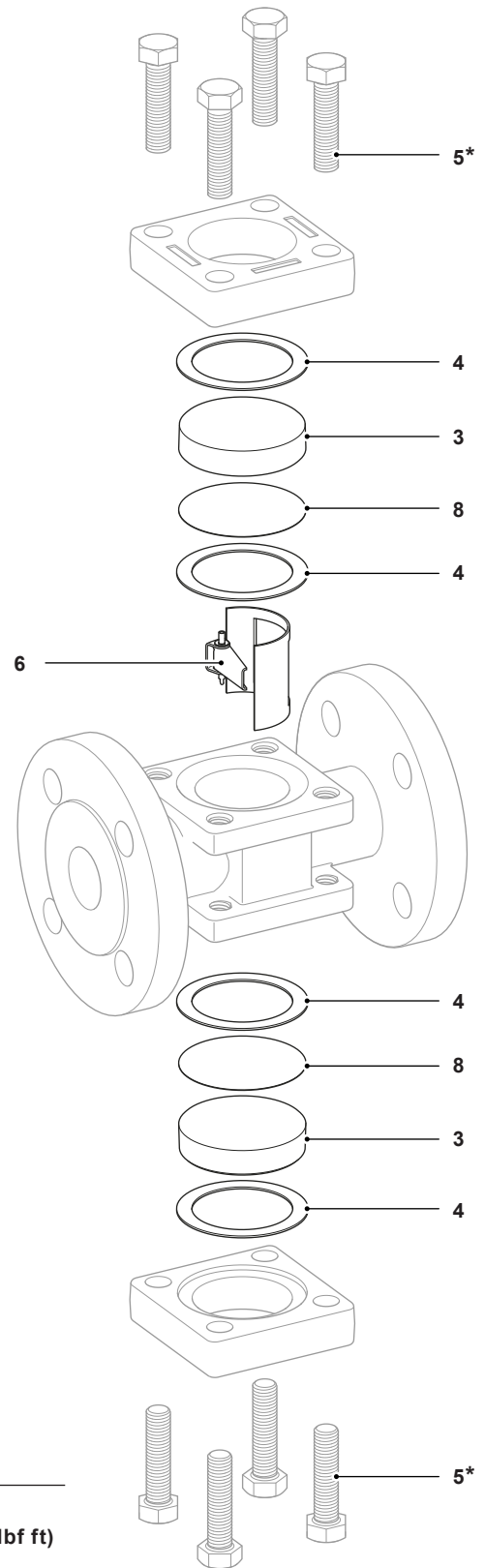
**Example:** 1 off Set of windows and gaskets for a Spirax Sarco DN20 SGC40 sight glass.



**Table 1 Recommended tightening torques**

Item	Size	Quantity	 or 	N m	(lbf ft)
<b>5</b>	DN15 - DN20	8	17 A/F M10 x 35	12	8.8
	DN25 - DN32 Flanged	8	19 A/F M12 x 50	28	20.6
	DN32 Screwed and socket weld, DN40 - DN50	8	19 A/F M12 x 60	38	28.0
	DN65 - DN100	8	23 A/F M16 x 85	132	97.3

\*  
Item 5  
is not an available spare.