



SG253 Sight Glass

Description

The SG253 is an SG iron double window sight glass with flanged connections.

Standards

This product fully complies with the requirements of the Pressure Equipment Directive (PED) and carries the  mark when so required.

Certification

This product is available with a Typical Test Report and is also available with certification to EN 10204 3.1 if specified.

Note: All certification/inspection requirements must be stated at the time of order placement.

Sizes and pipe connections

DN15, DN20, DN25, DN32, DN40 and DN50

Flanged EN 1092 PN25 and BS 1560 ASME (ANSI) Class 150.

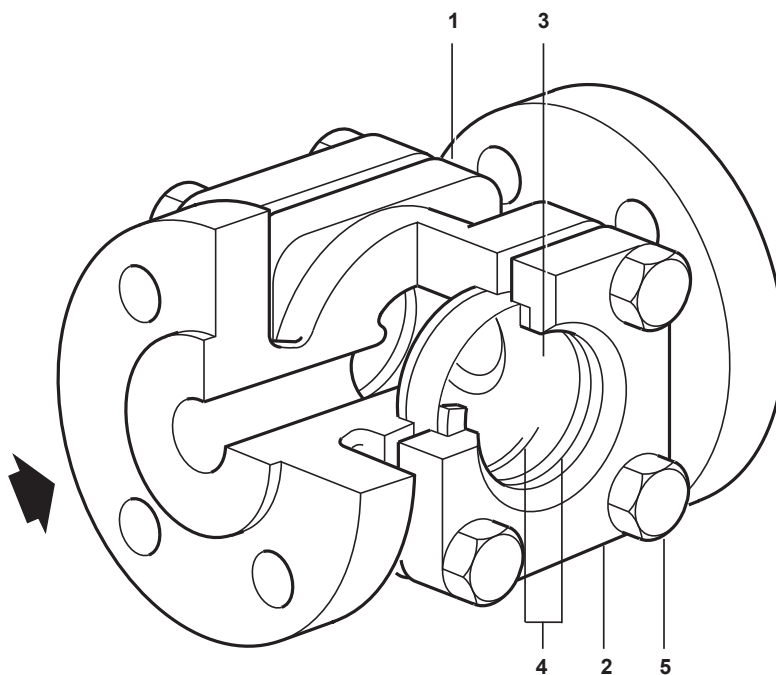

Material

No.	Part	Material	
1	Body	SG iron	DIN 1693 GGG 40.3
2	Cover	SG iron	DIN 1693 GGG 40.3
3	Window	Borosilicate glass	DIN 7080
4	Gaskets	Reinforced exfoliated graphite	
5	Cover bolts	Steel	BS 3692 Gr. 8.8

Pressure/temperature limits

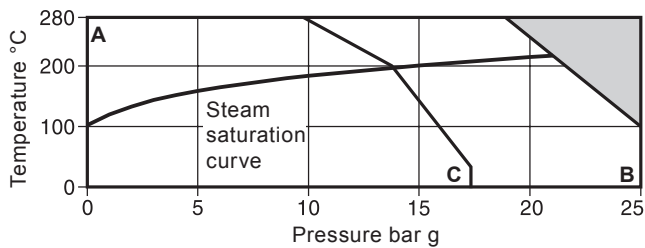

The product **must not** be used in this region.

A - B Flanged EN 1092 PN25

A - C Flanged BS 1560 ASME (ANSI) Class 150

Body design conditions	PN25 and ASME (ANSI) 150
PMA Maximum allowable pressure	PN25 25 bar g @ 100 °C
	ASME 150 17.2 bar g @ 35 °C
TMA Maximum allowable temperature	PN25 280°C @ 18 bar g
	ASME 150 280°C @ 10 bar g
Minimum allowable temperature	-10 °C
PMO Maximum operating pressure for saturated steam service	PN25 21 bar g
	ASME 150 13.8 bar g
TMO Maximum operating temperature	280 °C
Minimum operating temperature	0 °C
Note: For lower temperatures consult Spirax Sarco.	
Designed for a maximum cold hydraulic test pressure of:	PN25 38 bar g
	ASME 150 30 bar g
PTMX Maximum test pressure (steam service)	PN25 21 bar g
	ASME 150 13.8 bar g

Dimensions/weights (approximate) in mm and kg

Size	PN25		ASME 150		Weight
	A	A	B	E	
DN15	130	126	55	45	3.2
DN20	150	142	55	45	4.1
DN25	160	152	70	63	5.0
DN32	180	175	70	63	5.9
DN40	200	199	90	80	9.1
DN50	230	228	90	80	10.9

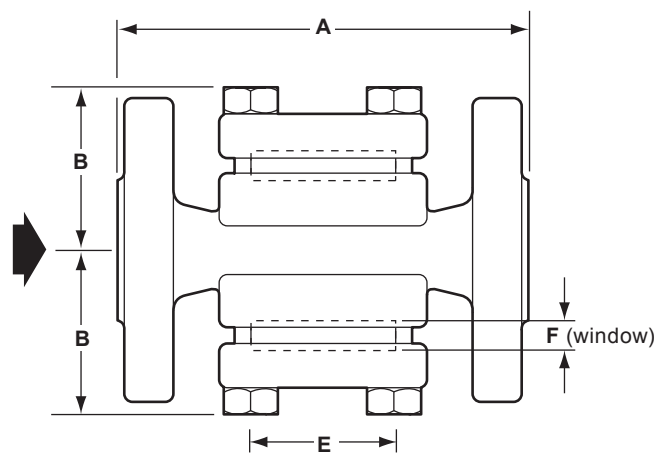

Safety information, installation and maintenance

For full details see the Installation and Maintenance Instructions (IM-S32-04) supplied with the product.

Warning:

Under certain conditions corrosive elements in condensate can affect the inside face of the window, particularly where caustic alkali and hydrofluoric acid are present. It is recommended that the sight glass is periodically checked for thinning of the window. If there is evidence of thinning or erosion damage then the window should be replaced immediately. Always wear eye protection when viewing the contents of the sight glass.

Reasonable steps should be taken to protect personnel from injury in the unlikely event that the window breaks.

Installation and maintenance note:

Sight glasses should have stop valves fitted on both the inlet and outlet. It is imperative that the upstream stop valve is closed first in order to prevent overpressurisation.

Sight glasses can be fitted in either a horizontal or vertical line on the outlet side of a steam trap. Where the trap is a blast discharge type e.g. thermodynamic, the sight glass must be fitted at least 1 m from the trap. This is to ensure that the glass is not subjected to thermal shock or pressure.

Ensure access is available for maintenance purposes

Disposal

The product is recyclable. No ecological hazard is anticipated with disposal of this product providing due care is taken.

How to order

Example: 1 off Spirax Sarco DN20 SG253 sight glass having an SG iron body, removable toughened glass windows and flanged EN 1092 PN25 connections.

Spare parts

The spare parts available are shown in solid outline. Parts drawn in a grey line are not supplied as spares.

Available spares

Set of windows and gaskets	3, 4
----------------------------	------

Please note: For the DN25 and DN32 sizes a set of bolts (16 A/F M10 x 40) is also included due to the increased thickness of the glass.

Set of gaskets	4
----------------	---



How to order spares

Always order spares by using the description given in the column headed 'Available spares' and state the size and type of the sight glass.

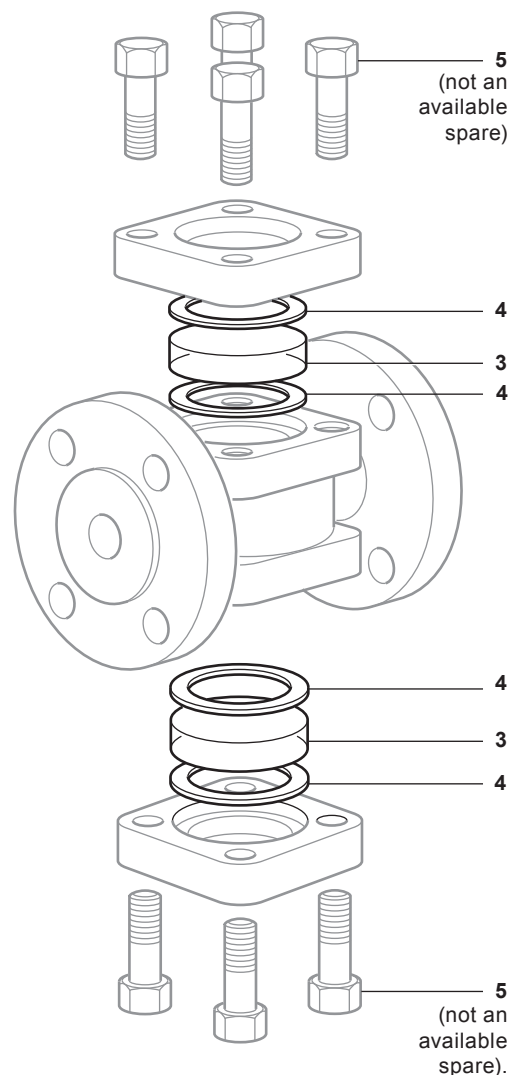
Example: 1 off Set of windows and gaskets for a Spirax Sarco SG253 sight glass.



Recommended tightening torques

Item	Size	Qty		or mm		N m
5	DN15 - DN20	8	17 A/F		M10 x 30	12
	DN25 - DN32		Pre 08-2010:	17 A/F	M10 x 35	28
			Post 08-2010:	16 A/F	M10 x 40	
	DN40 - DN50		19 A/F	M12 x 40	38	