



S5 Carbon Steel Separator

Description

The S5 is a carbon steel baffle type separator used for the removal of entrained liquids in steam, compressed air and gas systems.

Optional extras

Insulation jackets are available which will increase the performance of the separator, (see TI-P138-01).

Standards

This product fully complies with the requirements of the EU Pressure Equipment Directive/UK Pressure Equipment (Safety) Regulations and carries the **CE** mark when so required.

Certification

This product is available with certification to EN 10204 3.1.
Note: All certification/inspection requirements must be stated at the time of order placement.

Sizes and pipe connections

1/2", 3/4", 1", 1 1/4", 1 1/2" and 2"

Screwed BSP or NPT, butt weld, socket weld.

DN15, DN20, DN25, DN32, DN40 and DN50.

Flanged EN 1092 PN40 with screwed BSP drain and air vent.

Flanged BS 1560 (ASME) Class 150 or 300 with screwed NPT drain and air vent.

Flanged JIS/KS 10K and 20K with screwed BSP drain and air vent.

Note: For larger sizes use an S7 separator.
See TI-P138-03.

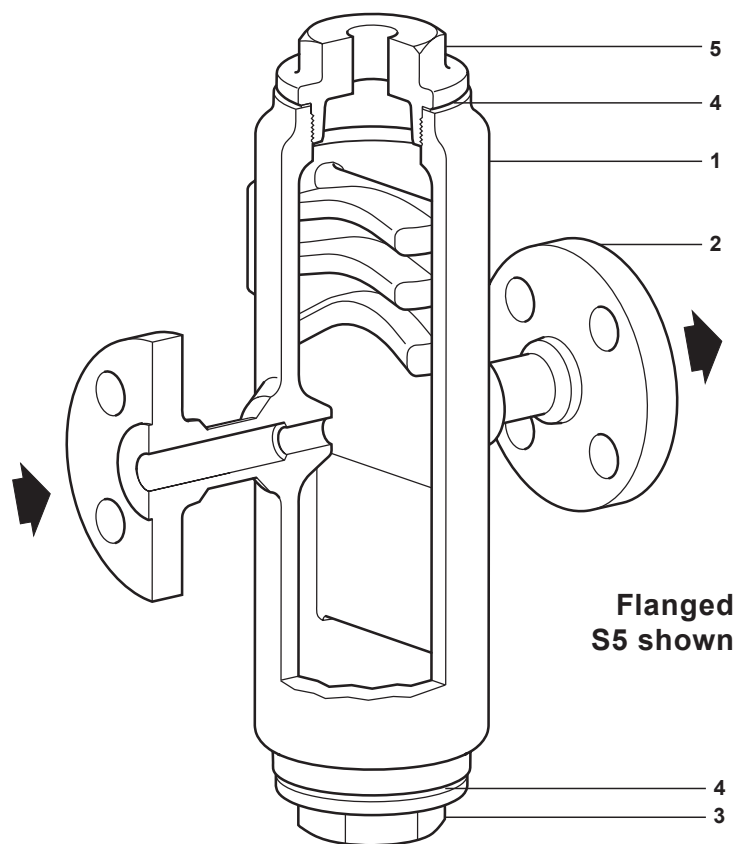

Materials

No.	Part	Material	
1	Body	Carbon steel	1.0619 +N/ASTM A216 WCB
2	Flange	Carbon steel	DIN 17243 C22.8/ASTM A105N
3	Cap	Carbon steel	1.0460
4	Cap gasket	Reinforced exfoliated graphite	
5	Cap	Carbon steel	1.0460

Pressure/temperature limits

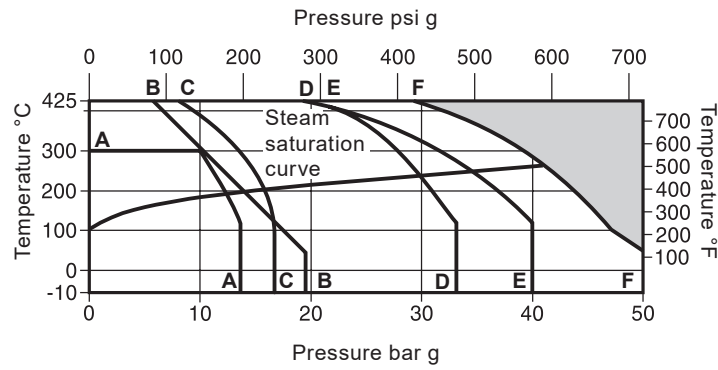

The product **must not** be used in this region.

- A - A** Flanged JIS/KS 10K.
- B - B** Flanged ASME Class 150.
- C - C** Flanged EN 1092 PN16.
- D - D** Flanged JIS/KS 20K.
- E - E** Flanged EN 1092 PN40.
- F - F** Screwed BSP, NPT, socket weld and butt weld.

Body design conditions		PN50 or ASME 300
PMA Maximum allowable pressure	50 bar g @ 50 °C	(725 psi g @ 122 °F)
TMA Maximum allowable temperature	425 °C @ 28 bar g	(797 °F @ 406 psi g)
Minimum allowable temperature	-10 °C	(14 °F)
	JIS/KS 10K	12.5 bar g (181 psi g)
	PN16	13.8 bar g (200 psi g)
	ASME 150	15.0 bar g (217 psi g)
PMO Maximum operating pressure for saturated steam service	JIS/KS 20K	30.0 bar g (435 psi g)
	PN40	35.9 bar g (520 psi g)
	ASME 300	41.4 bar g (600 psi g)
	Scrd/SW/BW	41.4 bar g (600 psi g)
TMO Maximum operating temperature	425 °C @ 28 bar g	(797 °F @ 406 psi g)
Minimum operating temperature	-10 °C	(14 °F)
Note: For lower operating temperatures consult Spirax Sarco.		
	JIS/KS 10K	20.6 bar g (299 psi g)
	PN16	24.0 bar g (348 psi g)
	ASME 150	30.0 bar g (435 psi g)
Designed for a maximum cold hydraulic test pressure of:	JIS/KS 20K	50.0 bar g (725 psi g)
	PN40	60.0 bar g (870 psi g)
	ASME 300	76.6 bar g (1 111 psi g)
	Scrd/SW/BW	76.6 bar g (1 111 psi g)

Note: Flanged separators (S5) may be supplied with a lower pressure rating than that cast into the body. Reference should be made to the appropriate operating chart to determine the actual product limitations.

Dimensions (approximate)

mm	Size	Screwed SW, BW A	PN16 A	PN40 A	ASME 150 A	ASME 300 A	JIS/KS 10K & 20K A	B	C	D	F	G	H
	DN15 - 1/2"	130	-	204	204	204	204	150	294	68	25.4	12.7	83
	DN20 - 3/4"	130	-	212	212	212	212	146	347	68	25.4	12.7	83
	DN25 - 1"	178	-	260	260	260	260	170.5	386	68	25.4	12.7	130
	DN32 - 1 1/4"	190	-	277	277	277	277	195	440	68	25.4	12.7	144
	DN40 - 1 1/2"	220	-	314	314	314	314	208	508	68	25.4	25.4	168
	DN50 - 2"	214	-	314	314	314	314	208	558	68	25.4	25.4	168

inches	Size	Screwed SW, BW A	PN16 A	PN40 A	ASME 150 A	ASME 300 A	JIS/KS 10K & 20K A	B	C	D	F	G	H
	DN15 - 1/2"	5.11	-	8.03	8.03	8.03	8.03	5.90	11.57	2.67	1"	1/2"	3.26
	DN20 - 3/4"	5.11	-	8.34	8.34	8.34	8.34	5.74	13.66	2.67	1"	1/2"	3.26
	DN25 - 1"	7.00	-	10.23	10.23	10.23	10.23	6.71	15.19	2.67	1"	1/2"	5.11
	DN32 - 1 1/4"	7.48	-	10.90	10.90	10.90	10.90	7.67	17.32	2.67	1"	1/2"	5.66
	DN40 - 1 1/2"	8.66	-	12.36	12.36	12.36	12.36	8.18	20.00	2.67	1"	1"	6.61
	DN50 - 2"	8.42	-	12.36	12.36	12.36	12.36	8.18	21.96	2.67	1"	1"	6.61

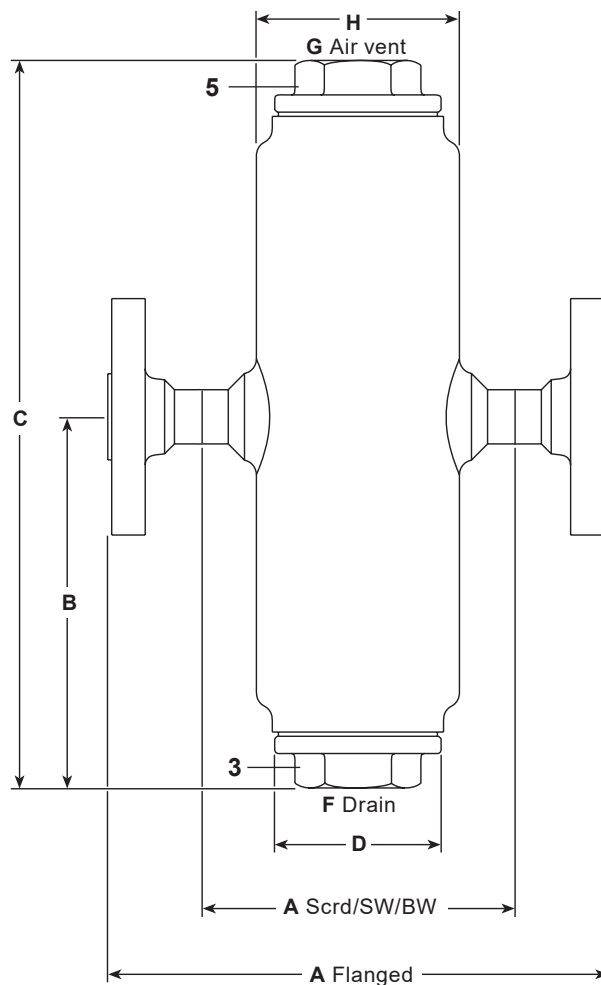

Weights/volume (approximate)

	Size	Weight		Volume	
		Scrd/SW/BW	Flanged	Scrd/SW/BW	Flanged
	kg and litres	DN15 - ½"	5.8	7.4	0.71
DN20 - ¾"		6.75	9.1	0.90	0.92
DN25 - 1"		12	14.8	2.83	2.86
DN32 - 1¼"		15.9	20	4.15	4.19
DN40 - 1½"		22.0	26.6	6.93	7.00
DN50 - 2"		23.9	30.1	7.74	7.88

	Size	Weight		Volume	
		Scrd/SW/BW	Flanged	Scrd/SW/BW	Flanged
	lbs and gallons	DN15 - ½"	12.78	16.31	0.18
DN20 - ¾"		14.88	20.06	0.23	0.24
DN25 - 1"		26.45	32.62	0.74	0.75
DN32 - 1¼"		35.05	44.09	1.09	1.10
DN40 - 1½"		48.50	58.64	1.83	1.84
DN50 - 2"		52.69	66.35	2.04	2.08

Recommended tightening torques

Item	Size		N m	
			(lbf ft)	
3 and 5	DN15 - DN50	46 A/F	180 - 200	133 - 150)

Safety information, installation and maintenance

For full details see the Installation and Maintenance Instructions (IM-P023-55) supplied with the product.

Installation note:

Install in a horizontal pipeline with the drain directly below.

To ensure that any separated liquid is drained quickly, a suitable steam trap/liquid drainer must be connected to the drain connection. For those steam systems where air can be present, air can collect in the upper portion of the separator. In this situation a suitable air vent should be connected to the air vent connection.

If an air vent is not being fitted then the connection must have the plastic transit protection plug removed and must have a carbon steel class 3000 lb plug fitted.

Disposal:

The product is recyclable. No ecological hazard is anticipated with disposal providing due care is taken.

How to order

Example: 1 off Spirax Sarco DN20 S5 separator with a carbon steel body flanged to EN 1092 PN40.