

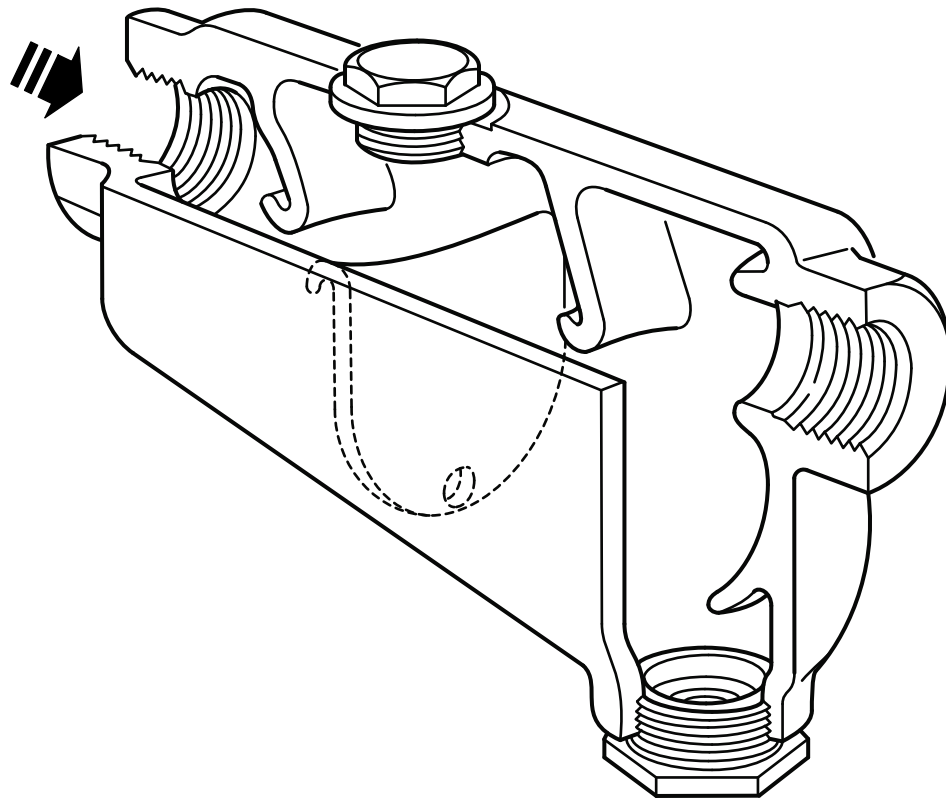

TI-P023-25  
CMGT Issue 5

## S12 SG Iron Separator (Screwed)



### Description

The S12 separator is an SG iron baffle type separator used for the removal of entrained liquids in steam, compressed air or gas systems. The fitting of insulation jackets will increase the performance of the separator.

### Standards

This product fully complies with the requirements of the Pressure Equipment Directive (PED).

### Certification

This product is available with a manufacturers' Typical Test Report.

**Note:** All certification/inspection requirements must be stated at the time of order placement.

### Sizes and pipe connections

1/4", 1/2" and 2" screwed BSP with screwed BSP drain or

1/4", 1/2" and 2" screwed NPT with screwed NPT drain.

## Materials

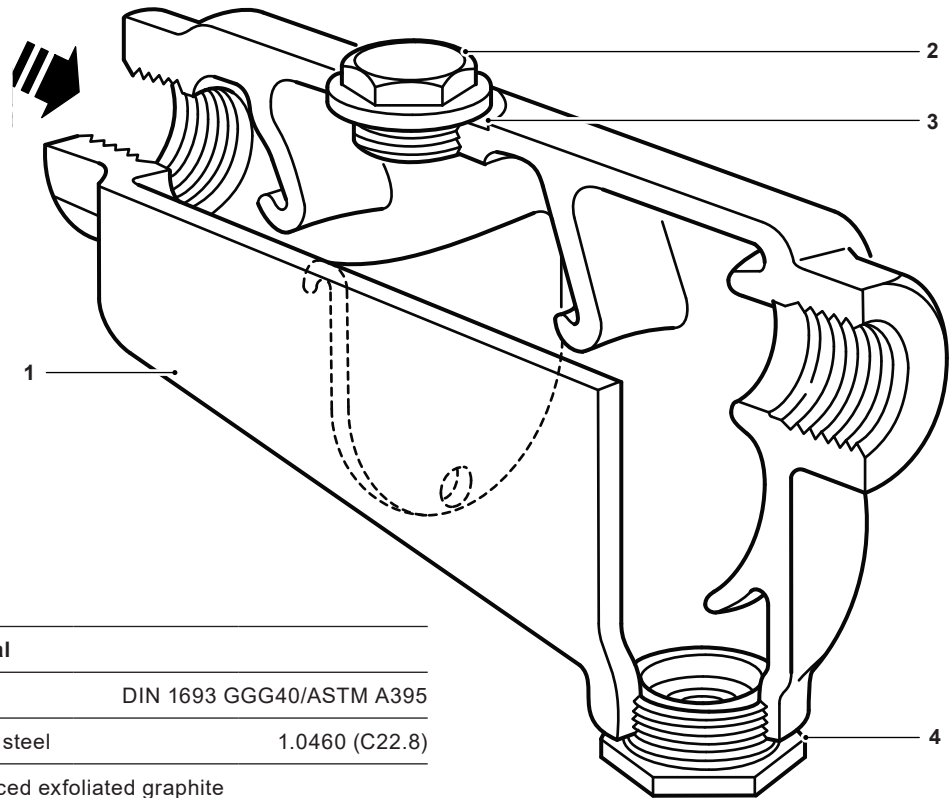

No.	Part	Material
1	Body	SG iron DIN 1693 GGG40/ASTM A395
2	Plug (2" only)	Carbon steel 1.0460 (C22.8)
3	Gasket (2" only)	Reinforced exfoliated graphite
4	Drain reducing bush	Forged carbon steel ASTM A105

## Pressure/temperature limits (ISO 6552)

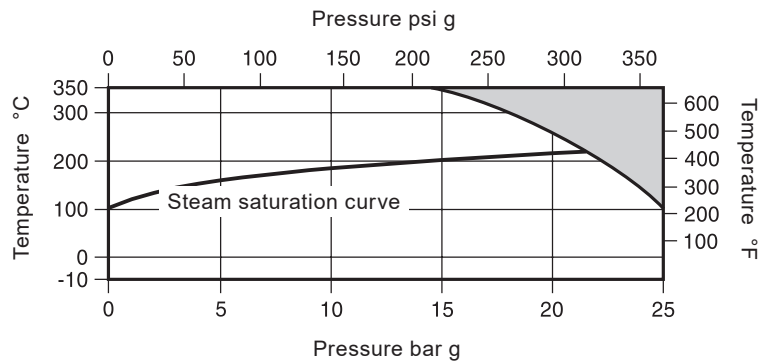

The product **must not** be used in this region.

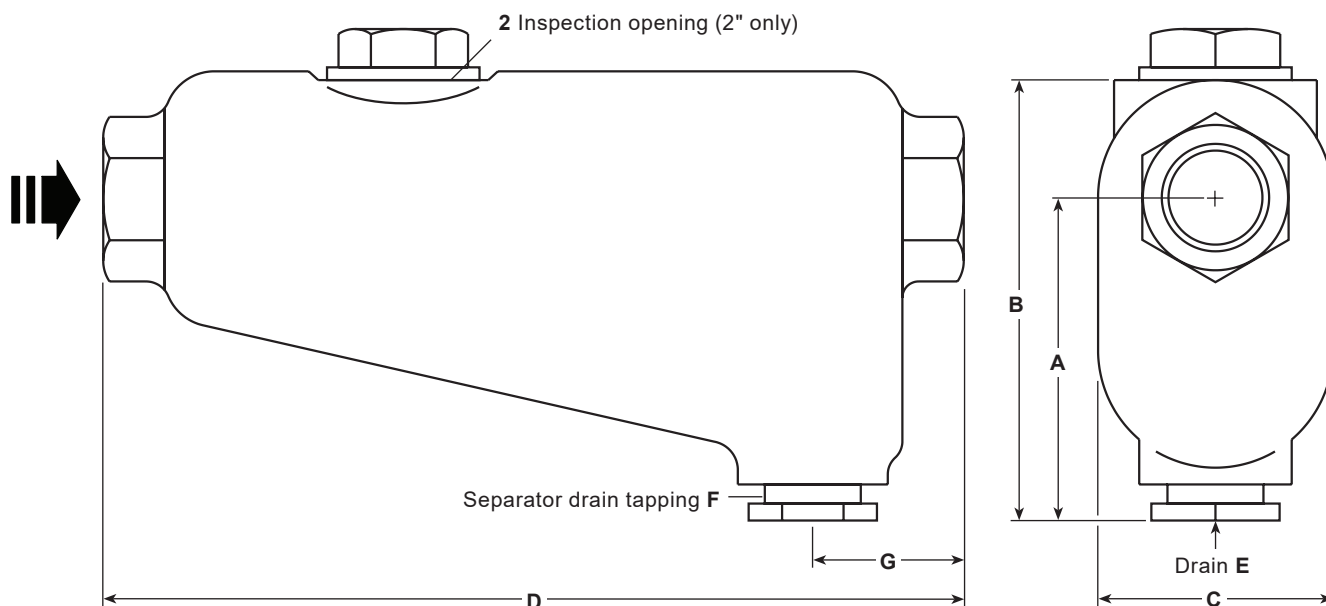

Body design conditions		PN25	
PMA	Maximum allowable pressure	25 bar g @ 100 °C	(363 psi g @ 212 °F)
TMA	Maximum allowable temperature	350 °C @ 14 bar g	(662 °F @ 203 psi g)
	Minimum allowable temperature	-10 °C	(14 °F)
PMO	Maximum operating pressure for saturated steam service	21.3 bar g	(309 psi g)
TMO	Maximum operating temperature	350 °C @ 14 bar g	(662 °F @ 203 psi g)
	Minimum operating temperature	-10 °C	(14 °F)
<b>Note:</b> For lower operating temperatures consult Spirax Sarco.			
Designed for a maximum cold hydraulic test pressure of:		38 bar g	(551 psi g)

**Dimensions, weights and volumes approximate in mm (inches), kg (lbs) and litres (gallons)**



	Size	A	B	C	D	E	F	G	Weight	Volume
mm, kg and litres	1¼"	111	156	89	304	12.7	25.4	60	9.0	1.5
	1½"									
	2"	146	205	117	397	12.7	25.4	71	17.0	3.2
	Size	A	B	C	D	E	F	G	Weight	Volume
inches, lbs and gallons	1¼"	4.37	6.14	3.5	12	½"	1"	2.36	19.8	0.40
	1½"									
	2"	5.75	8.07	4.61	15.6	½"	1"	2.80	37.5	0.85

**Recommended tightening torques**

Item	Size	 or mm		N m	(lbf ft)
2	2"	46 A/F	M56	150 - 165	(110 - 121)

**Safety information, installation and maintenance**

For full details see the Installation and Maintenance Instructions (IM-P023-55) supplied with the product.

**Installation note:**

Install in a horizontal pipeline with the drain directly below.

**Note:** To ensure that any separated liquid is drained away quickly, a suitable liquid drainer or steam trap must be connected to the drain connection 'E' - consult Spirax Sarco for further details.

**Disposal**

This product is recyclable. No ecological hazard is anticipated with the disposal of this product, providing due care is taken.

**How to order**

**Example:** 1 off 2" Spirax Sarco S12 separator with SG iron body having screwed BSP connections.