



PPC and PPF Pressure Powered Pumps

Available types

PPC cast iron body and cover, with gunmetal check valves.
PPF fabricated steel body and cover, with steel check valves.
Connecting nipples are not supplied with check valves.

Limiting conditions

Body design conditions	PPC - 8.6 bar g (up to 232 °C)
	PPF - 8.6 bar g (up to 343 °C) (ASME stamped — (ASME Boiler and Pressure Vessel Code Section VIII Div 1)).

Operating inlet pressure.

Steam, air or gas, 0.34 to 8.6 bar g.

Total lift or back pressure which must be below operating pressure to allow capacity to be achieved.

Height (H) in metres x 0.0981 plus pressure (bar g) in return line, plus downstream piping friction pressure drop in bar calculated at a flow rate of the lesser of six times the actual condensate rate or 20,000 L/h.

Filling head recommended above the pump is 0.3 m.

Minimum filling head 0.15 m (reduced capacity.)

Standard pump operates with liquids of specific gravity 1.0 down to 0.9, specify when ordering for liquid specific gravity from 0.9 to 0.65.

Pump discharge per cycle:- PPC 27 L, PPF 32 L.

Each cycle at a maximum flow rate of 20,000 L/h.

Steam consumption — 3 kg. of steam per 1000 kg liquid pumped.

Air consumption — 6230 L_n per 1000 kg liquid pumped.

Sizes and pipe connections

1", 1½", 2" and 3" x 2"	PPC Screwed bsp (BS21 - parallel)
	PPF Screwed API

Installation

For best operation any flash steam must be vented or condensed ahead of pump inlet.

Full details are given in the Installation and Maintenance Instructions supplied with each pump

Optional extras

Flow counter for measuring liquid pumped.

A plugged boss is provided on the pump cover, screwed ½" API for connecting the counter. The flow counter body is brass and must be installed in a vertical position. Flow counter can only be used when pump exhaust is vented to atmosphere.

Gauge glass with brass cocks.

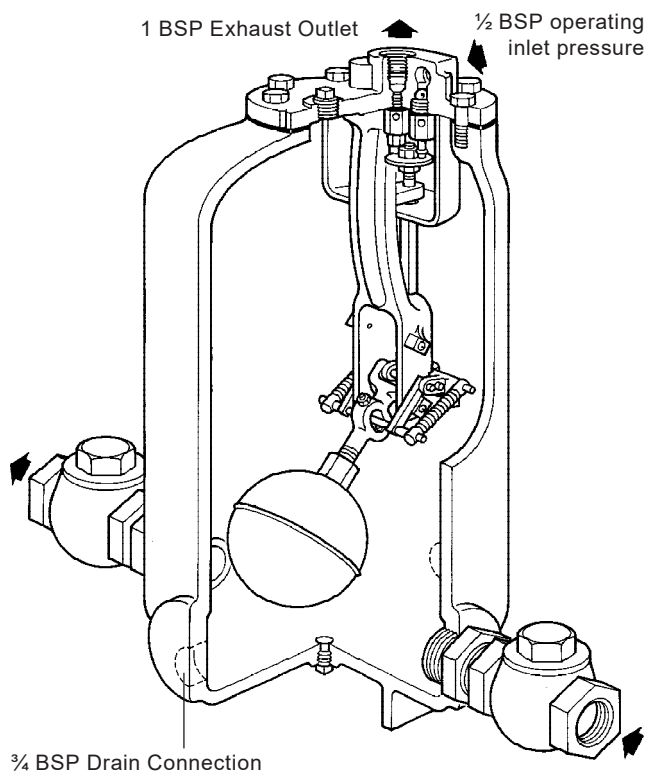

Materials

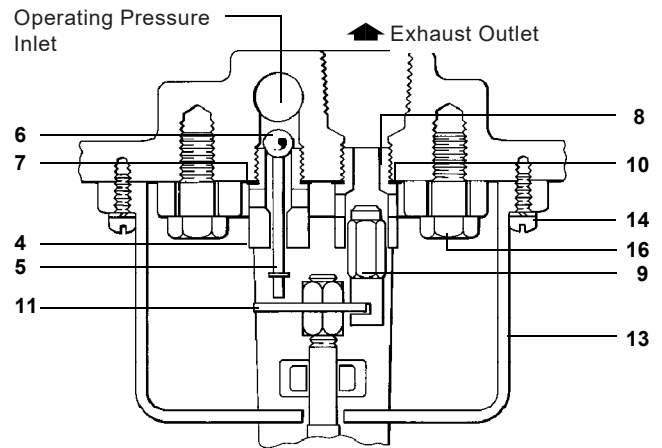
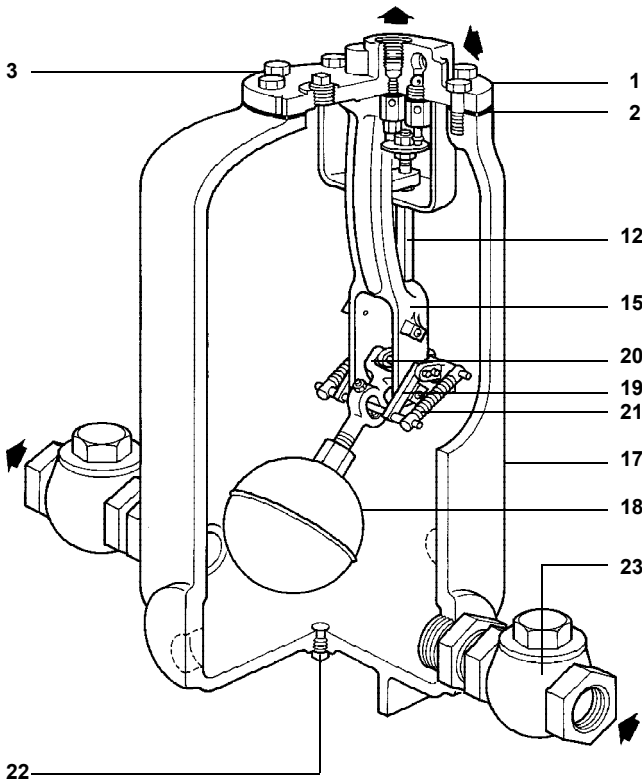

No.	Part	Material		
1	Cover	PPC	Cast Iron	ASTM A126 Class B
		PPF	Cast Steel	ASTM A216 WCB
2	Cover Gasket	Graphite	Union Carbide GHP	
3	Cover Screws	Steel	$\frac{1}{2}$ " -13 x1 $\frac{1}{4}$ "	SAE 1035 Gr. 5
4	Inlet Valve Seat	Stainless Steel	AISI 303	
5	Inlet Valve Stem	Stainless Steel	AISI 303	
6	Inlet Valve Head	Stainless Steel	AISI 440	
7	Inlet Valve Seat Gasket	Stainless Steel	AISI 302	
8	Exhaust Valve Seat	Stainless Steel	AISI 303	
9	Exhaust Valve	Stainless Steel	AISI 303	
10	Exhaust Valve Seat Gasket	Stainless Steel	AISI 301	
11	Valve Actuator Disc	Stainless Steel	AISI 302	

No.	Part	Material		
12	Push Rod	Stainless Steel	AISI 303	
13	Baffle	Cast Iron	ASTM A126 Class B	
14	Baffle Screws	Stainless Steel	$\frac{1}{4}$ " — 20 x $\frac{3}{4}$ "	AISI 303
15	Mechanism Yoke	Cast Iron	ASTM A126 Class B	
16	Mechanism Yoke	Stainless Steel	$\frac{1}{2}$ " — 13 x 1 $\frac{1}{4}$ "	AISI 304 Screws
17	Body	PPC	Cast Iron	ASTM A126 Class B
		PPF	Carbon Steel	+ ASTM SA414 G
18	Float & Arm	Stainless Steel	AISI 304	
19	Linkage Mechanism	Stainless Steel	AISI 303/304	
20	Push Rod Actuator	Stainless Steel	AISI 304	
21	Spring	Stainless Steel	AISI 316	
22	Plug $\frac{1}{2}$ "	Forged Steel	ASTM A105	
23	Check Valves	PPC	Gunmetal	BS 1400 LG1
		PPF	Cast Steel	ASTM A216 WCB

+ Alternatives are sometimes used.

Dimensions/weights (approximate) in mm and kg

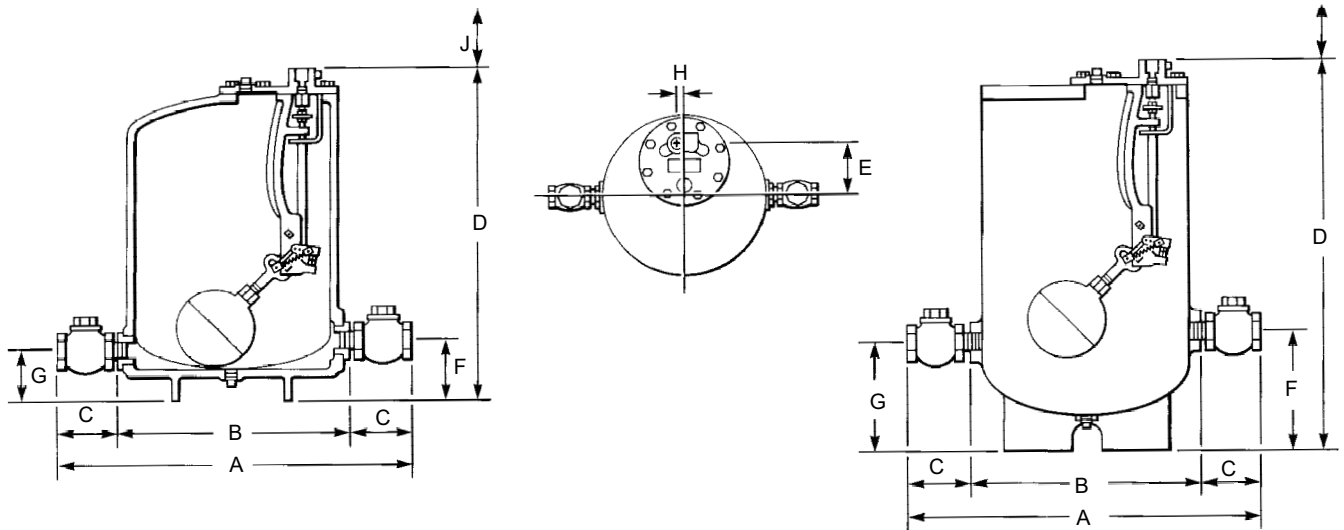

PPC

Size	A	B	C	D	E	F	G	H	J	Weight	
										Pump	Cv's
1"	648	441	86	633	129	114	99	16	300	100 kg	3.2 kg
1½"	705	438	108	633	129	114	99	16	300	100 kg	5.2 kg
2"	749	413	133	633	129	114	99	16	300	100 kg	7.7 kg
3" x 2"	806	413	181	633	129	114	99	16	300	100 kg	15.9 kg

PPF

1"	743	476	114	798	129	279	264	16	300	70 kg	3.2 kg
1½"	845	473	159	798	129	279	264	16	300	70 kg	5.2 kg
2"	883	448	184	798	129	279	264	16	300	70 kg	7.7 kg
3" x 2"	911	457	181	798	129	279	264	16	300	70 kg	15.9 kg

How to specify

1 - SPIRAX SARCO Pressure Powered Pump type PPC with cast iron body size 2", complete with gunmetal check valves, and flow counter. All external connections to be screwed bsp.

Selection and Sizing

See TI-P135-03.

Note: If you are in any doubt about the size of pump required or if the conditions are unusual we will be glad to advise you if you will give us the answers to the following questions:-

- 1) Nature of liquid to be pumped.
- 2) Temperature of liquid to be pumped.
- 3) Quantity to be pumped (L/h).
- 4) Initial lift horizontal distance and net effective lift (i.e. initial lift less subsequent fall in discharge line).
- 5) Operating medium (steam, compressed air or gas).
- 6) Operating pressure available.
- 7) The pump is generally used to drain water from a vented receiver but under certain circumstances can drain a unit from under steam pressure or vacuum.State which.

Note: To achieve rated capacity, pump must be installed with check valves as supplied by Spirax Sarco. Use of a substitute check valve may affect the performance of the pump.

Spare parts for sizes 1", 1½", 2" and 3" x 2"

The spare parts available are shown in heavy outline. Parts drawn in broken line are not available as spares.

Available spares

Cover Gasket	B
Float	F
Inlet/Outlet Check Valve (each)	M
Cover and Internal mechanism Assembly	A,B,F (complete)

Recommended tightening torque

Cover bolts — 80/88 Nm

How to Order

Always order spares by using the description given in the columns headed Available Spare and by stating the size and type of pump.
Example — 1 — Cover Gasket for 2" SPIRAX SARCO PPC Pressure Powered Pump.

