



## PC4\_ Pipeline Connectors

### Description

The PC4\_ range of pipeline connectors have been designed for use with swivel connector steam traps. The PC4\_ is a pipeline connector with two integral stop valves which isolate upstream and downstream of the steam trap. The stop valves are piston type. The PC4\_ is available with optional connections (BDV1 and/or BDV2) for the draining of upstream pipework and trap venting upstream and trap testing downstream of the steam trap - See 'Optional extras'.

### Optional extras (see TI-P600-01 for further details)

BDV1 blowdown valve is available for the draining of upstream pipework and trap testing downstream of the steam trap during operation. Care should be taken when using the BDV1 blowdown valve as the discharge may be hot.

BDV2 depressurisation valve is available to provide side connection discharge, generally to be used as a vent for top pipe mounting or for line depressurisation, to ensure discharge is piped to grade/atmosphere.

### Standards

These products fully comply with the requirements of the European Pressure Equipment Directive 2014/68/EU.

### Certification

These products are available with certification to EN 10204 3.1.

**Note:** All certification/inspection requirements must be stated at the time of order placement. For other certification contact Spirax Sarco.

### Sizes and pipe connections

DN15 and DN20 condensate inlet/outlet connections are available in screwed BSP T Rp (ISO 7-1) or NPT and socket weld ends to ASME B16.11 class 3000. Drainage and venting connections are available in DN15 screwed BSP T Rp (ISO 7-1) or NPT and socket weld connections for use with BDV1 or BDV2 valves.

Flanged versions are also available upon request. Please contact Spirax Sarco for further details.

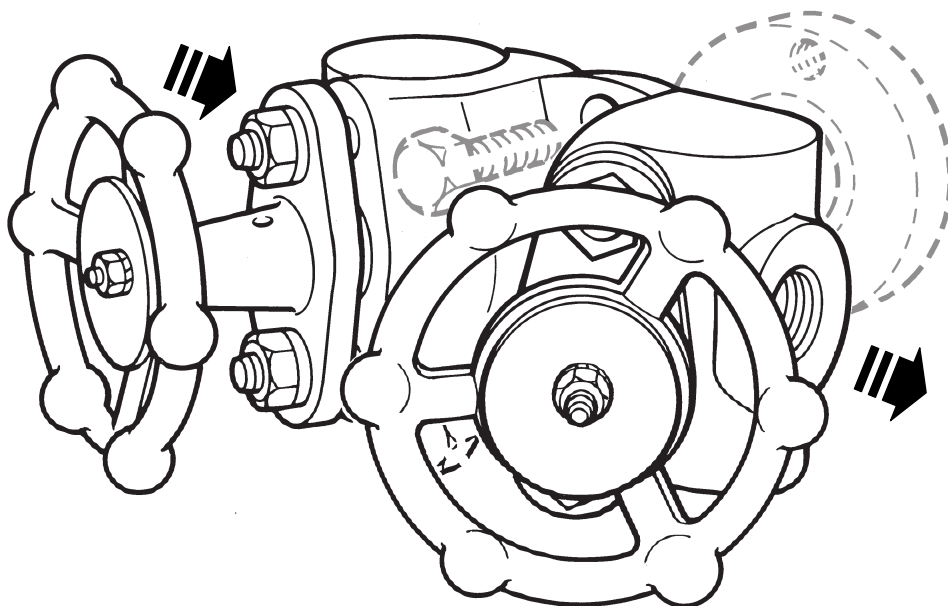

## Available types

For piping installation diagrams see TI-F01-37.

Flow direction	Type	Description
Left to right	PC43	2 stop valves + upstream line drain and trap vent connections + downstream trap test connections for: BDV1 or BDV2
Right to left	PC44	2 stop valves + upstream line drain and trap vent connections + downstream trap test connections for: BDV1 or BDV2
Universal -	PC40	2 stop valves
Both: left to right or right to left	PC45	2 stop valves + upstream line drain connection either side of the body for: BDV1 or BDV2. It is necessary to plug one connection. This must always be the top connection.
Left to right	PC46	2 stop valves + upstream line drain connection + downstream trap test connections for: BDV1 or BDV2
Right to left	PC47	2 stop valves + upstream line drain connection + downstream trap test connections for: BDV1 or BDV2

## Pressure / temperature limits

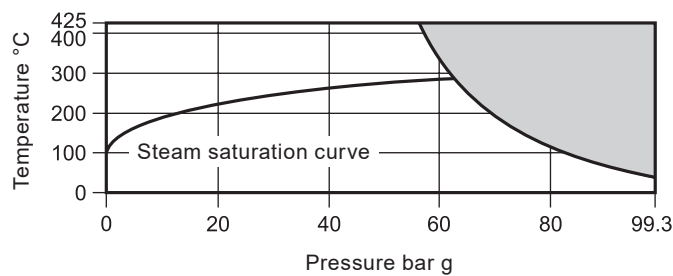

The product **must not** be used in this region.

- Notes:**
1. If flange connections are fitted then these will limit the maximum design conditions of the pipeline connector.
  2. The maximum operating limits of the complete assembly will be dictated by the steam trap of choice. Reference the specific steam trap technical information sheet for its 'Pressure / temperature limits'.

Body design conditions	ASME class 600
PMA Maximum allowable pressure	99.3 bar g @ 38 °C
TMA Maximum allowable temperature	425 °C @ 56 bar g
PMO Maximum operating pressure for saturated steam service	62 bar g
TMO Maximum operating temperature	425 °C @ 56 bar g
Product is safe for use under full vacuum conditions	
Designed for a maximum cold hydraulic test pressure of	150 bar g

## Kv value

Both the DN15 and DN20 have a Kv value of Kv 1.8

For conversion:

$$Cv (UK) = Kv \times 0.963$$

$$Cv (US) = Kv \times 1.156$$

## Materials

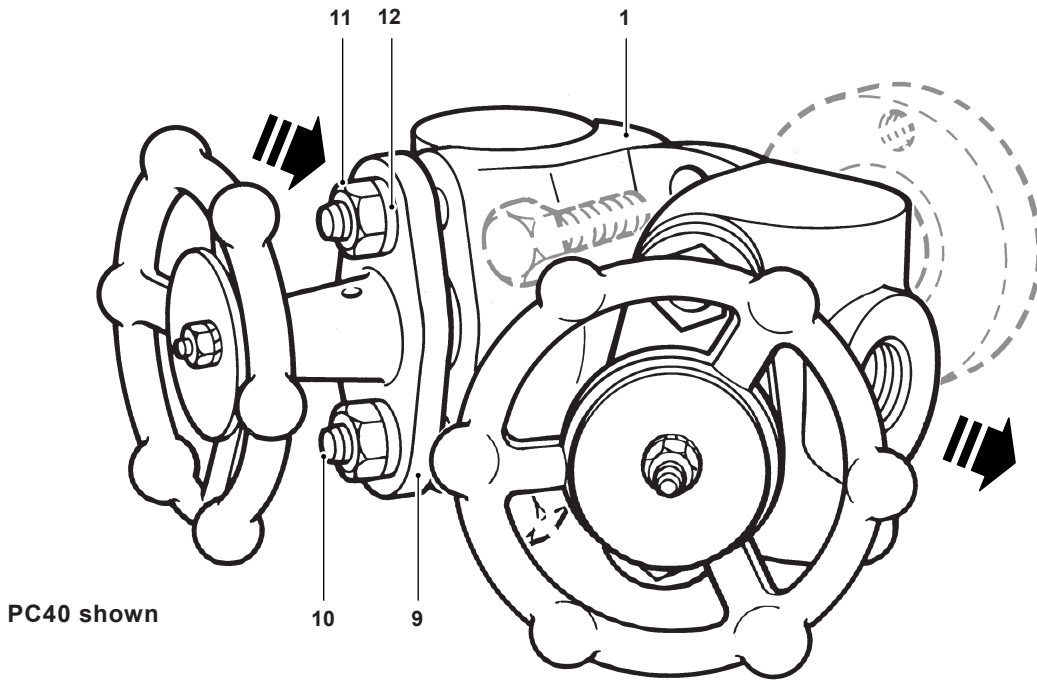

PC40 shown

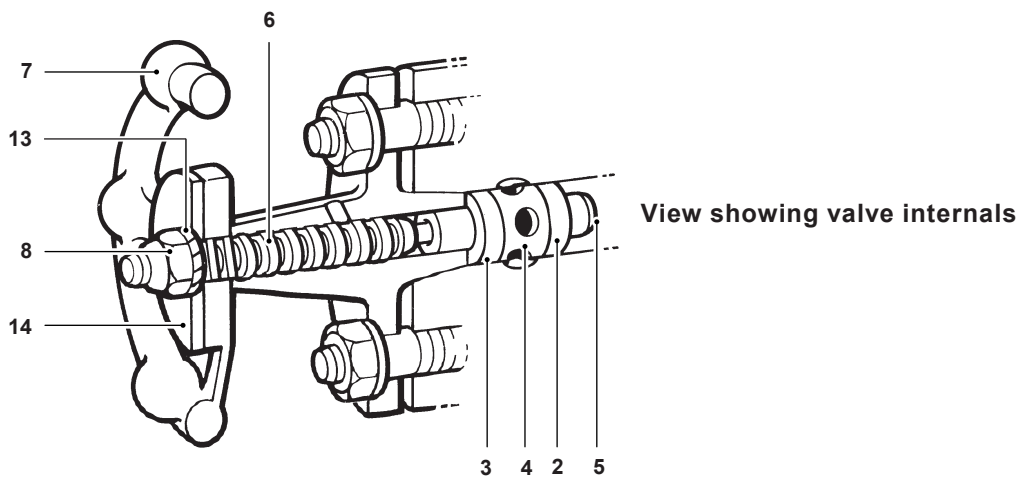

No.	Part	Material
1	Body	Austenitic stainless steel ASTM A182 F304/304L
2	Lower ring	Graphite and stainless steel
3	Upper ring	Graphite and stainless steel
4	Lantern bush	Steel UNI 4838 CF95 SMn Pb36
5	Piston	Stainless steel ASTM A479 F316
6	Spindle	Steel ASTM A479 F410
7	Handwheel	Carbon steel ASTM A105N

No.	Part	Material
8	Handwheel nut	Stainless steel and nylon insert
9	Bonnet	Carbon steel ASTM A105N
10	Studs	Steel (ENP) ASTM A193-B7
11	Nuts	Steel (ENP) ASTM A194-2H
12	Washers	Steel
13	Washer	Steel
14	Name-plate	Stainless steel

**Dimensions / weight** (approximate) in mm and kg

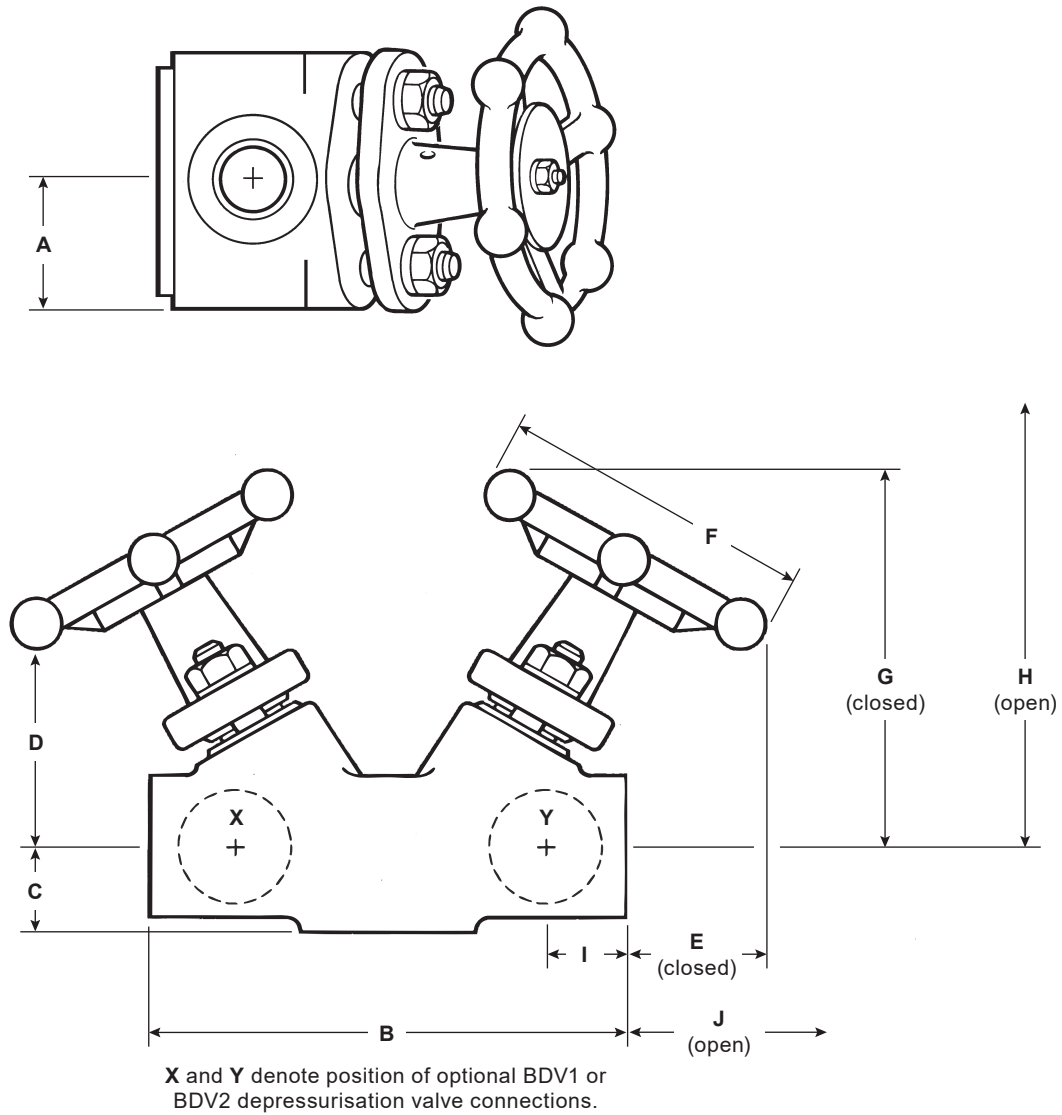

A	B	C	D	E	F	G	H	I	J	Weight
36	125	25	50	35	90	99	115	22	50	3

## Safety information

### Pressure

Before attempting any maintenance, consider what is or may have been in the pipeline. Ensure that any pressure is isolated and safely vented to atmospheric pressure before attempting to maintain the steam trap. This is easily achieved by fitting Spirax Sarco depressurisation valves types BDV1 and BDV2 (see separate literature for details). Do not assume that the system is depressurised even when a pressure gauge indicates zero.

### Temperature

Allow time for temperature to normalise after isolation to avoid the danger of burns and consider whether protective clothing (including safety glasses) is required.

### Isolation

Consider whether closing isolating valves will put any other part of the system or personnel at risk. Dangers might include; isolation of vents, protective devices or alarms. Ensure isolation valves are turned off in a gradual way to avoid system shocks.

## Installation

### General

There are two criteria which must be satisfied to ensure that the swivel connector trap will operate correctly and ensure effective condensate removal:

1. The PC4\_ shall be installed with flow in the direction of the arrow. Flow can be horizontal (left to right or right to left), vertical or inclined.
2. The connection face for the swivel connector steam trap must be in the vertical plane.

Ensure that there is sufficient access to the handwheel to allow proper operation. After installation it is recommended that the pipeline connector is insulated to minimise radiated heat losses and to protect personnel from burns risk: Please note that some steam trap types should not be insulated.

### Optional BDV1 and/or BDV2

If the optional BDV1 and/or BDV2 is being fitted to your application for line drain, trap vent or trap testing, consideration must be given to the position of the discharge - See TI-P600-01 for further information. The discharge must be directed or piped to a safe place where it will not injure personnel nor damage plant.

The BDV1 provides straight through discharge, generally used as a line drain or trap test valve where discharge is directed to grade. The BDV2 provides a side connection discharge, generally used as a trap vent or to ensure discharge is piped to grade.

### Maintenance

For detailed Installation and Maintenance Instructions see IM-P128-06, which is supplied with the product.

### Disposal

This product is recyclable. No ecological hazard is anticipated with the disposal of this product, providing due care is taken.

## How to order

Example: 1 off Spirax Sarco PC40 pipeline connector having a forged austenitic stainless steel body with two integral piston valves and DN15 socket weld connections to ASME B 16.11 Class 3000.

**Note:** Where BDV1 or BDV2 valves are to be fitted they must be ordered separately - See TI-P600-01.

## Spare parts

The spare parts available are shown in heavy outline. Parts drawn in grey broken line are not supplied as spares. For ease of replacement an extractor tool is available for removing the sealing rings.

### Available spares

Sealing ring set	2, 3
Valve internals set	2, 3, 4, 5, 6, 8, 13
Extractor tool	Not shown



### How to order spares

Always order spares by using the description given in the column headed 'Available spares' and state type and size of equipment.

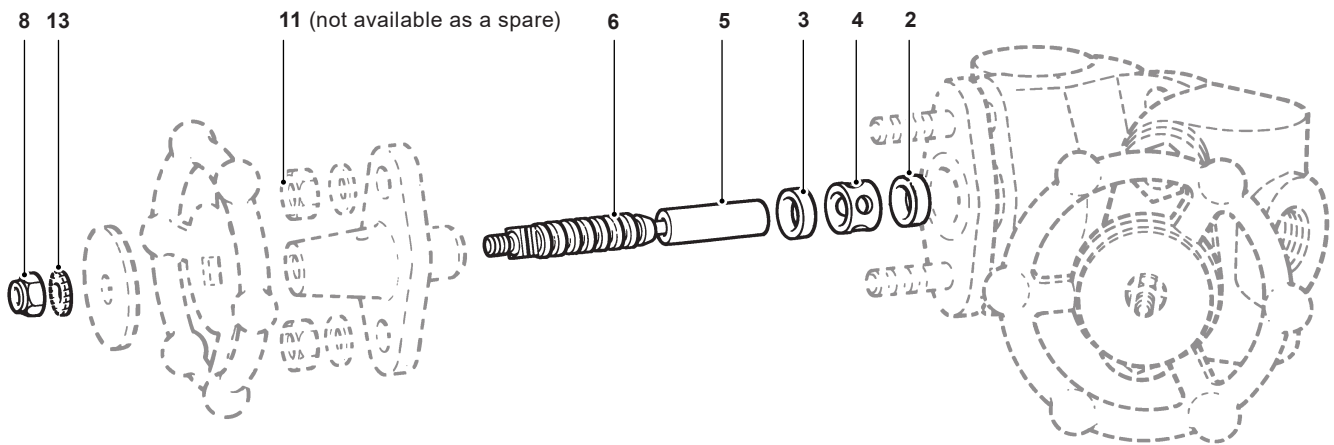
**Example:** 1 off Sealing ring set for integral piston valve on a PC4\_ pipeline connector having DN15 socket weld connections.



**Table 1 Recommended tightening torques**

Item	 or mm		N m	(lbf ft)
11	14 A/F	5/16 x 18 UNC	10	(2.24)
8	10 A/F	M6	0.1	(0.02)