



PC10HP Pipeline Connector

Description

The PC10HP pipeline connector is designed for use with swivel connector steam traps up to the maximum pressure/temperature limitations of the selected steam trap.

The principle is that the pipeline connector can be fitted into the pipeline, either horizontally or vertically. The steam trap can be fitted afterwards to the connector and can be rotated through 360 ° to ensure that the trap is in the horizontal plane.

Standards

This product fully complies with the requirements of the European Pressure Equipment Directive 2014/68/EU.

Certification

This product is available with certification to EN 10204 3.1.

Note: All certification/inspection requirements must be stated at the time of order placement.

Sizes and pipe connections

Condensate inlet/outlet DN15, DN20 and DN25
 ½", ¾" and 1" screwed BSP T Rp (ISO 7-1) or NPT
 Socket weld ends to ASME B 16.11/BS 3799 Class 3000.
 Flanged versions are also available upon request.
 Please contact Spirax Sarco for further details.

The PC10HP has been designed for use with the following steam trap options:-

UBP32, UTD30L, UTD30H, UTDS46M, UTD52L, UIB30, UIB45, UFT32, USM21 and USM32.

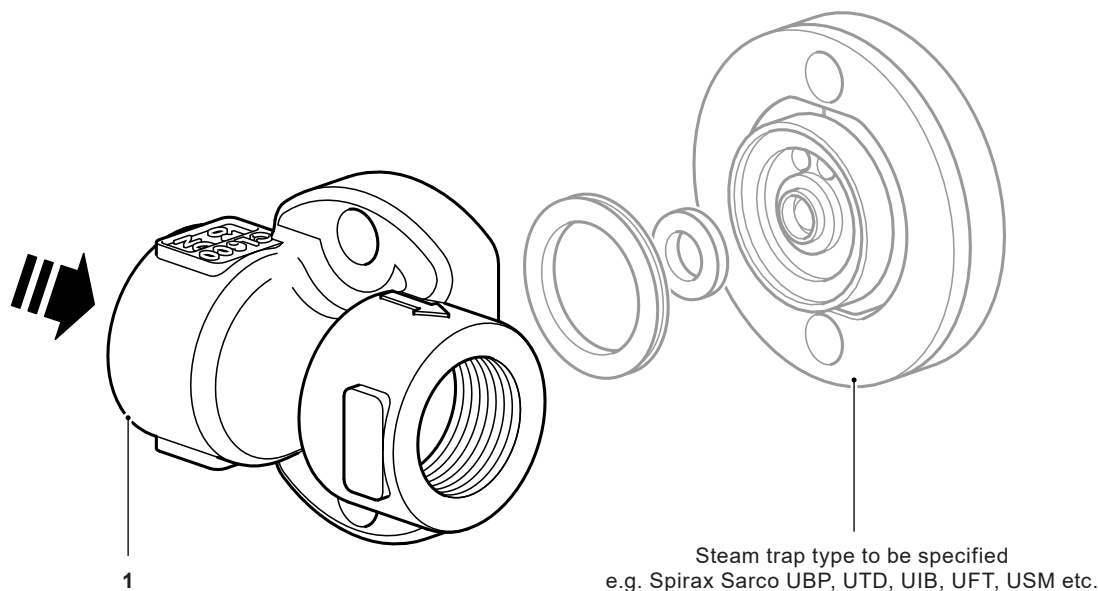

Materials

No.	Part	Material
1	Body	Austenitic stainless steel type 304 ASTM A 351 CF8

Kv values

Size	DN15	DN20	DN25	For conversion:
Kv	1.1	1.1	1.1	Cv (UK) = Kv x 0.963 Cv (US) = Kv x 1.156

Pressure/temperature limits (ISO 6552)

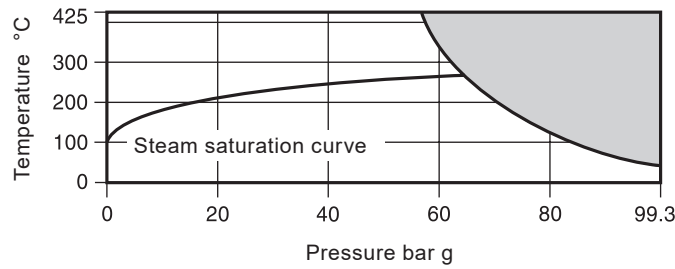

The product **must not** be used in this region.

Notes:

- If flange connections are fitted then these will limit the maximum design conditions of the pipeline connector.
- The maximum operating limits of the complete assembly will be dictated by the steam trap of choice. Reference the specific steam trap Technical Information sheet for its maximum pressure / temperature limitations.

Body design conditions	ASME Class 600
PMA Maximum allowable pressure	99.3 bar g @ 38 °C
TMA Maximum allowable temperature	425 °C @ 56 bar g
Minimum allowable temperature	0 °C
PMO Maximum operating pressure for saturated steam service	64 bar g
TMO Maximum operating temperature	425 °C @ 56 bar g
Minimum operating temperature	0 °C
Note: For lower operating temperatures consult Spirax Sarco	
Product is safe for use under full vacuum conditions	
Designed for a maximum cold hydraulic test pressure of	149 bar g

Dimensions/weights (approximate) in mm and kg

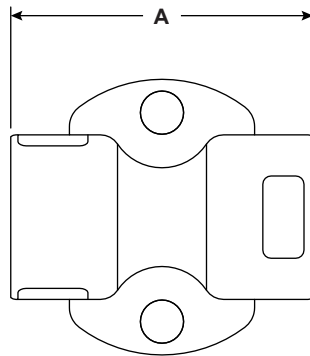

Size	A	Weight
1/2"	61.5	0.6
3/4"	73.5	0.7
1"	90.0	0.7

Safety information, installation and maintenance

For full details see Installation and Maintenance Instructions (IM-P128-13) supplied with the product.

Installation note:

There are following criteria must be satisfied to ensure that the steam trap will operate correctly and ensure effective condensate removal.

- The PC10HP shall be installed with flow in the direction of the arrow. Flow can be horizontal (either direction), vertical or inclined.
- The connection face for the swivel connector steam trap must always be in the vertical plane unless stated on relevant steam trap Installation and Maintenance Instructions.
- The correct steam trap and end connection must be selected to meet the system design conditions.
- Steam trap connector bolts are supplied with the selected steam trap.

After installation it is recommended that the pipeline connector is insulated to minimise radiated heat losses and to protect personnel from burns risk. Please note that there are some trap types that should not be insulated.

Detailed instructions regarding welding socket weld versions are provided with the product - See IM-P128-13.

An alternative pipeline connector is also available with integral strainer facility, called the PC20.
For further details please see TI-P128-15.

Suitable isolation valves must be installed to allow for safe maintenance/replacement -
Please see A3S (TI-P132-09) or RP31 (TI-P118-01).

Spirax Sarco can also supply pipeline connectors fitted with integral isolation valves and can incorporate line drainage and trap depressurisation facilities. Please see PC30 (TI-P128-02) or PC40 (TI-P128-03).

Disposal

The product is recyclable. No ecological hazard is anticipated with disposal of this product providing due care is taken.

How to order

Example: 1 off ½" Spirax Sarco PC10HP pipeline connector in austenitic stainless steel having socket weld end connections to ASME B 16.11 Class 3000 and a body ASME Class 600 rated.