

spirax sarco

TI-P626-02
 ST Issue 4

PBX20 and PBX30 Quick Fit Connector Bimetallic Steam Traps

Description

Spirax Sarco's PBX bimetallic steam traps comprise of a stainless steel trap assembly coupled to a carbon steel body connector. Pre-set and maintenance free, these steam traps can be mounted in any position. When the connector has been installed, the bimetallic trap assembly can be fitted within a few minutes without having to disturb the pipework.

PBX steam traps are particularly suitable for food, pharmaceutical and oil industries, and are designed for a wide range of applications such as tracing, drips and draining collectors.

Available types	PBX20	0.1 bar to 21 bar
	PBX30	10 bar to 32 bar

Standards

This product fully complies with the requirements of the European Pressure Equipment Directive 97/23/EC.

Certification

This product is available with certification to EN 10204 3.1.
Note: All certification / inspection requirements must be stated at the time of order placement.

Sizes and pipe connections

½", ¾" and 1" screwed BSP/NPT and socket weld.

Pressure/temperature limits

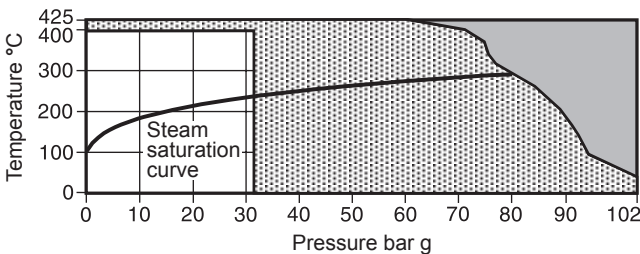

- The product **must not** be used in this region.
- The product should not be used in this region or beyond its operating range as damage to the internals may occur.

Body design conditions	PN110, Class 600 to ASME B 16.34	
PMA	Maximum allowable pressure	102 bar g @ 37.8°C
TMA	Maximum allowable temperature	425°C @ 60 bar g
Minimum allowable temperature		-10°C
PMO	Maximum operating pressure	PBX20 21.0 bar g @ 400°C
		PBX30 32.0 bar g @ 400°C
TMO	Maximum operating temperature	400°C
Minimum operating temperature		0°C
Minimum operating pressure for satisfactory operation	PBX20	0.1 bar g
	PBX30	10.0 bar g

ΔPMX The backpressure for correct operation must not exceed 90% of the upstream pressure.

Designed for a maximum cold hydraulic test pressure of 124 bar g

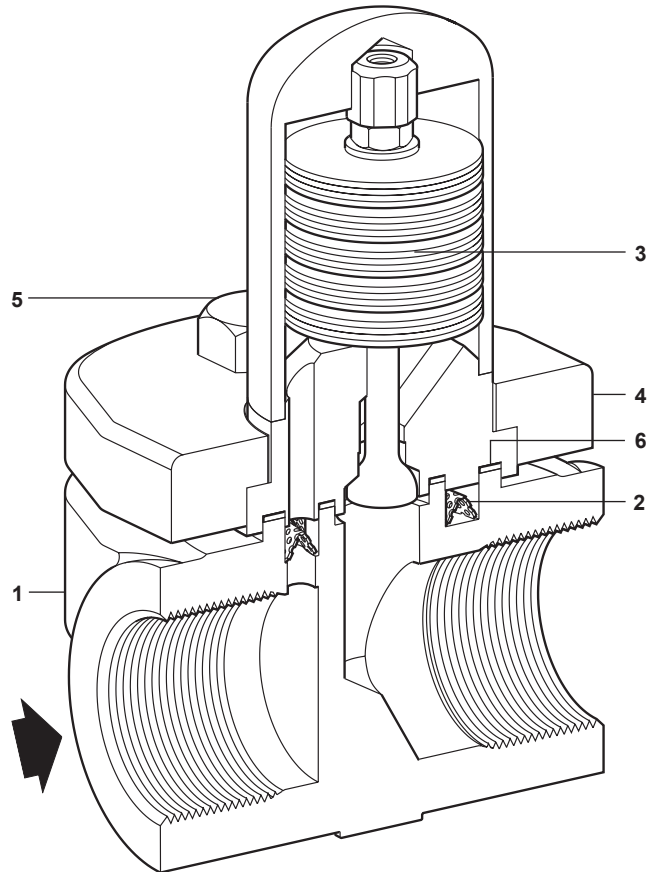

Materials

No.	Part	Material
1	Connector body	Carbon steel ASTM A105N
2	Strainer screen	Stainless steel AISI 304L
3	Bimetallic trap assembly	Stainless steel AISI 316L
4	Flange	Stainless steel or steel AISI 316L A105
5	Bolt	Stainless steel A4 - 80
6	Gasket	Graphite - stainless steel

Dimensions / weights (approximate) in mm and kg

PBX20 and PBX30

Size	A	B	C	D	Weight
½"	70	100	19	10	1.95
¾"	70	100	19	10	1.95
1"	80	100	24	10	2.10

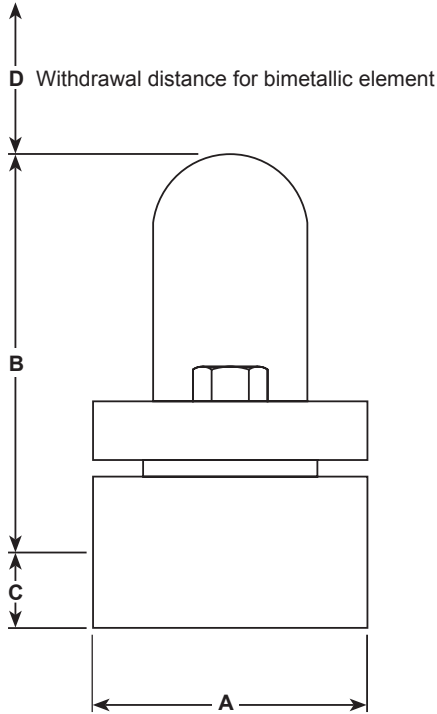

Spare parts

The spare parts available are detailed below. No other parts are supplied as spares.

Available spares

Bimetallic trap assembly with gasket and strainer screen **2, 3, 6**

How to order spares

Always order spares by using the description given in the column headed 'Available spares' and state the size and model of the bimetallic steam trap.

Example: 1 - Bimetallic trap assembly with gasket and strainer screen for Spirax Sarco ½" PBX20 bimetallic steam trap.

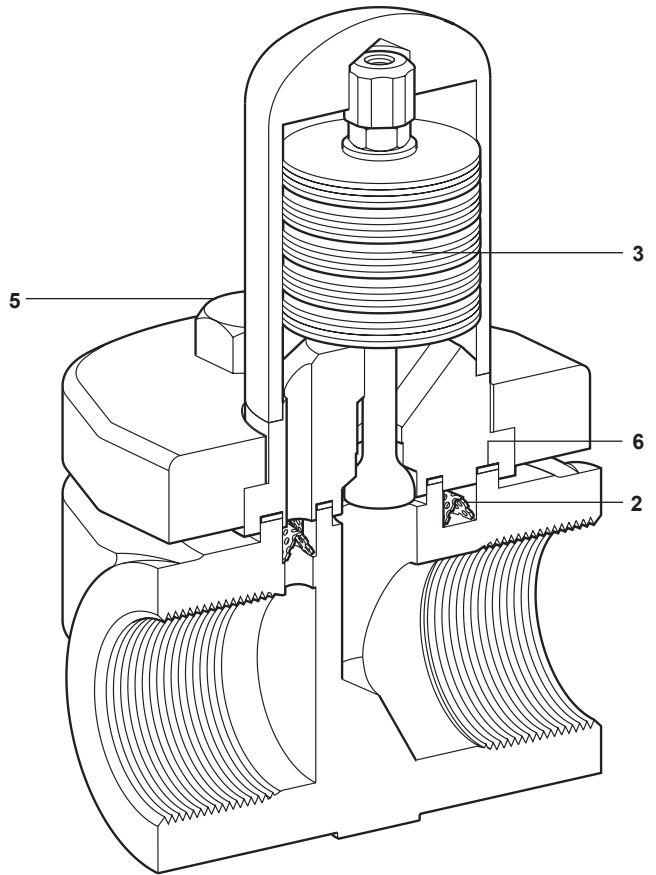

Capacities

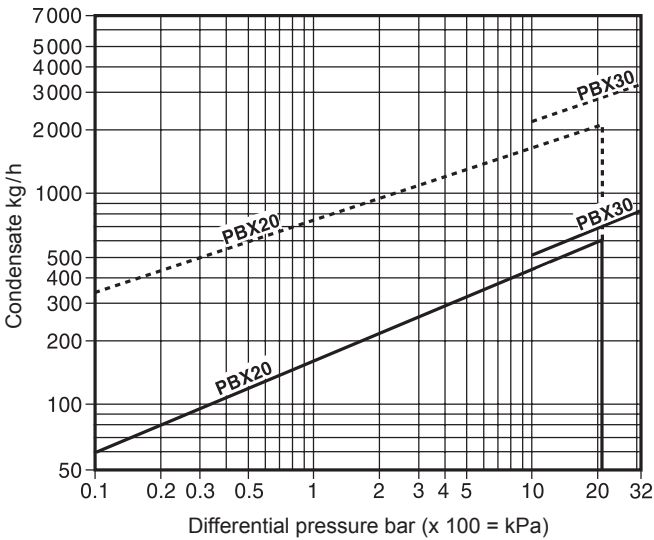

Hot water capacity ————— Cold water capacity - - - - -

Recommended tightening torques

Item		N m
5	16 A/F	45 - 55

Safety information, installation and maintenance

For full details see the Installation and Maintenance Instructions (IM-P626-01) supplied with the product.

How to order

Example: 1 off Spirax Sarco ½" PBX30 bimetallic steam trap with carbon steel quick fit connector having socket weld connections.