



Cert. No. LRQ 0963008

ISO 9001

# spirax sarco

**TI-P117-02**  
ST Issue 9

## MSC Manifolds - ASTM

### for Steam Distribution and Condensate Collection

#### Description

A range of forged carbon steel compact manifolds with integral piston type stop valves for steam distribution and condensate collection duty.

MSC manifolds can be used for either steam distribution duty or condensate collection duty depending on the way they are installed.

#### Operation

In operation the piston valve should be either fully open or fully closed: **It is not intended for throttling duties.**

As the piston valve has such a large sealing area it is not necessary to use a valve key to ensure dead tight shut-off.

#### Standards

This product fully complies with the requirements of the European Pressure Equipment Directive 97/23/EC.

#### Certification

The product is available with certification to EN 10204 3.1.

**Note:** All certification/inspection requirements must be stated at the time of order placement.

#### Pressure / temperature limits

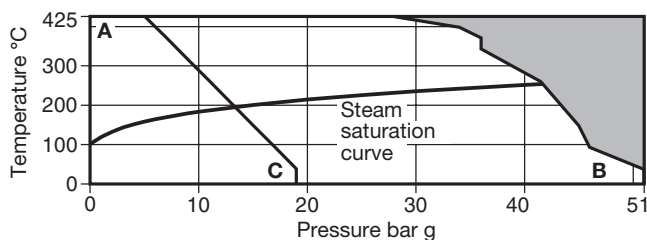

The product **must not** be used in this region.

**A - B** Flanged ANSI Class 300, screwed and socket weld.

**A - C** Flanged ANSI Class 150.

Body design conditions		ANSI Class 300 (PN50)	
PMA	Maximum allowable pressure	51 bar g @ 38°C	
TMA	Maximum allowable temperature	425°C @ 28 bar g	
Minimum allowable temperature	Standard (A105)	-29°C	
	See optional extras (LF2)	-46°C	
PMO	Maximum operating pressure for saturated steam service	ANSI 150	14 bar g
		ANSI 300, SW, NPT	41.5 bar g
TMO	Maximum operating temperature	ANSI 150	425°C @ 5.5 bar g
		ANSI 300, SW, NPT	425°C @ 28 bar g
Minimum operating temperature		0°C	

**Note:** For lower operating temperatures consult Spirax Sarco  
Designed for a maximum cold hydraulic test pressure of 76 bar g

#### K<sub>v</sub> values

All sizes  $K_v$  1.8

For conversion:  $C_v$  (UK) =  $K_v \times 0.963$   $C_v$  (US) =  $K_v \times 1.156$

The  $K_v$  stated is for each valve rather than the complete manifold.

#### Available types, sizes and pipe connections

MSC manifolds are available with 4, 8 or 12 connections designated:

**MSC04**, **MSC08** and **MSC12** respectively and flanged BS 1560 (ANSI) class 150 or 300 or socket weld to ANSI B 16.11 Class 3000 or screwed BSP or NPT.

The steam main/condensate return connection is **DN40**.

The tracer line and drain connections are available as **DN15**, **DN20** flanged, screwed BSP, NPT and SW to ANSI B 16.11. The **DN25** is available with flanged connections only.

#### Optional extras

The following are available at extra cost:

- An MSC manifold in ASTM A350 LF2 material for low ambient temperatures down to -46°C.
- Mounting kit comprising of studs, spacers and nuts.
- Insulating jacket for body and flanges.
- Fitted with steam traps for quick installation projects.

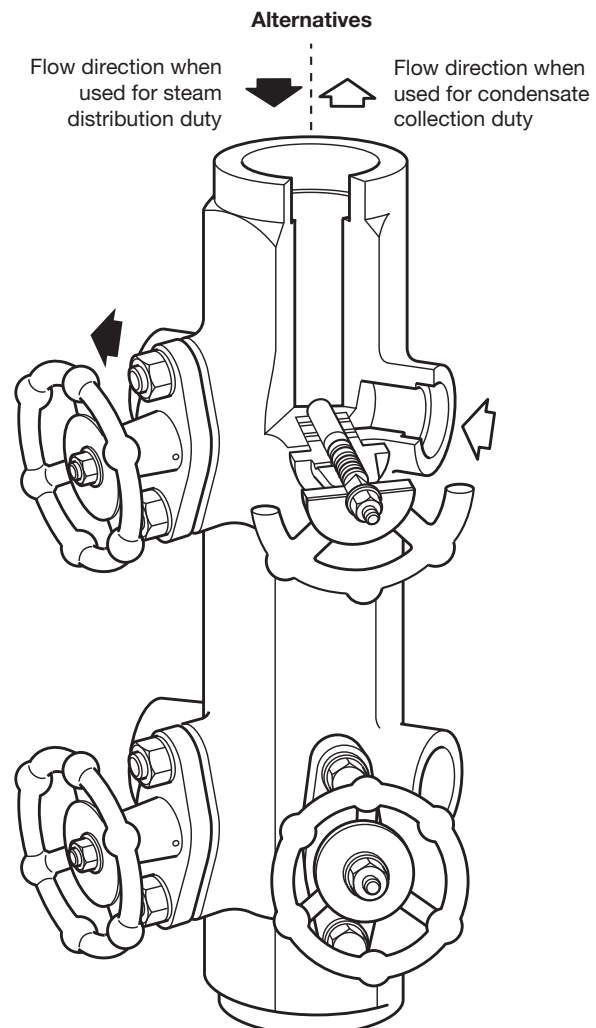

**MSC04** shown having socket weld connections

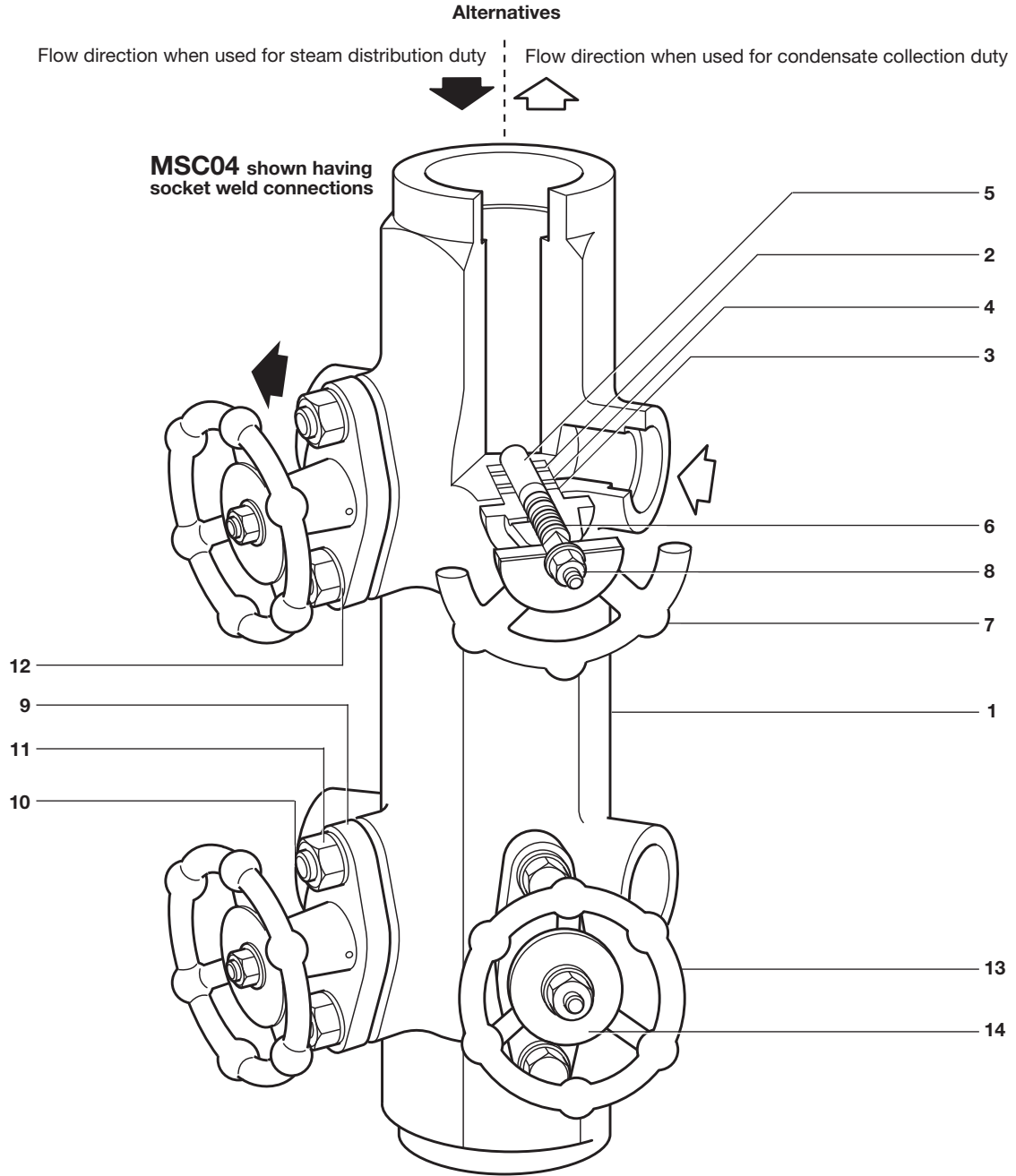

**Materials**

No.	Part	Material	
1	Body	Carbon steel	ASTM A105N or ASTM A350 LF2
2	Lower ring	Graphite and stainless steel	
3	Upper ring	Graphite and stainless steel	
4	Lantern bush	Steel	
5	Piston	Stainless steel	ASTM A479 F316
6	Spindle	Stainless steel	ASTM A479 F410
7	Handwheel	Carbon steel	ASTM A105N
8	Handwheel nut	Steel	
9	Bonnet	Carbon steel	ASTM A105N or ASTM A350 LF2
10	Studs	Stainless steel	ASTM A193 Gr. B8
11	Nuts	Stainless steel	ASTM A194 Gr. 8
12	Washers	Stainless steel	
13	Handwheel	Stainless steel	
14	Name-plate	Stainless steel	

**Dimensions/weights (approximate) in mm and kg**

Type	A	B	C	D	E	F	G	H	J	K	L	M	N	Weight
MSC04	330	160	85	110	71	48	37.5	75	102	120	50	M12	45	10
MSC08	650	160	85	110	71	48	37.5	75	102	120	50	M12	45	20
MSC12	970	160	85	110	71	48	37.5	75	102	120	50	M12	45	30

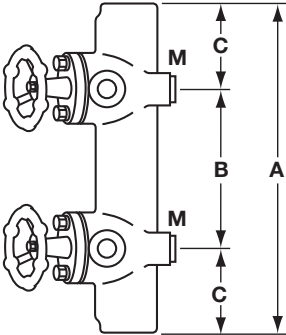
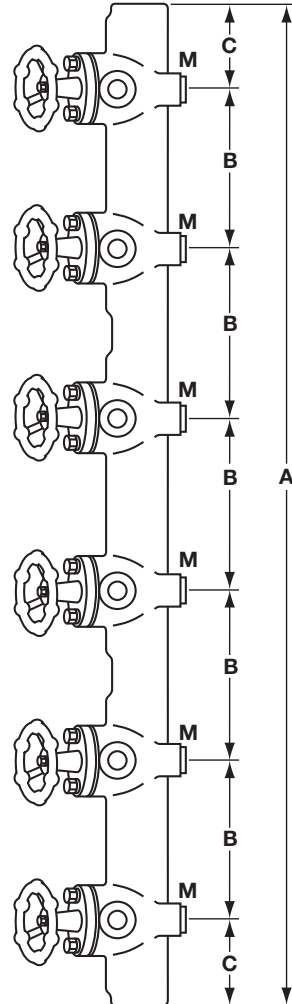
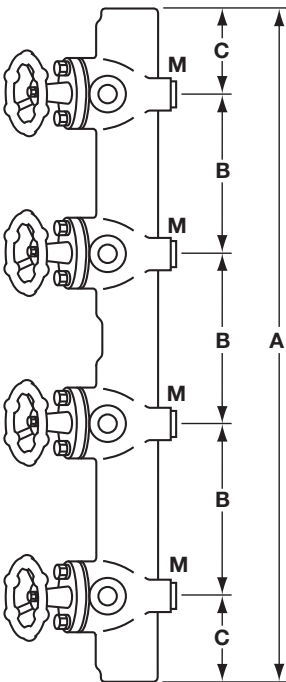
**MSC04****MSC12****MSC08****Safety information, installation and maintenance**

For full details see the Installation and Maintenance Instructions (IM-P117-03) supplied with the product.

**General**

These manifolds have been designed for vertical installation. The back is provided with threaded connections M12 for ease of installation by attaching to a supporting structure.

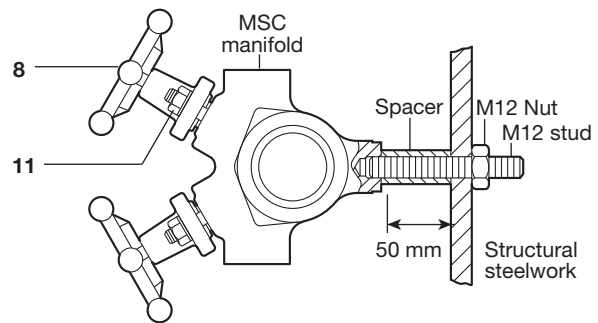
**Installation view from above****Mounting kits**

The manifold is generally conveniently attached to the structural steelwork supporting the plant.

For ease of installation it is recommended that spacers are fitted to give the manifold a stand-off of at least 50 mm.

**For convenience the following sets of mounting kit are available:**

- A single set comprising 2 off each stud, nut and spacer suitable for installing one MSC04 or MSC08.
- A single set comprising 4 off each stud, nut and spacer suitable for installing one MSC12.
- A multiple set comprising 12 off each stud, nut and spacer suitable for installing 6 x MSC04, 6 x MSC08 or 3 x MSC12.

After installation it is recommended that the manifold is insulated to minimise radiated heat losses and to protect personnel from burn risks. This is most easily done using the optional insulating jacket.

**Steam distribution duty**

The recommended installation is with the steam inlet connection at the top of the manifold. A trap set should be fitted to the bottom. The discharge from this trap set should ideally be returned. If it is to be discharged to atmosphere we recommend that a diffuser is fitted.

**Condensate collection duty**

The recommended installation is with the condensate outlet at the top. The bottom of the manifold should be fitted with a stop valve for blowdown purposes. Again, we recommend that a diffuser is fitted.

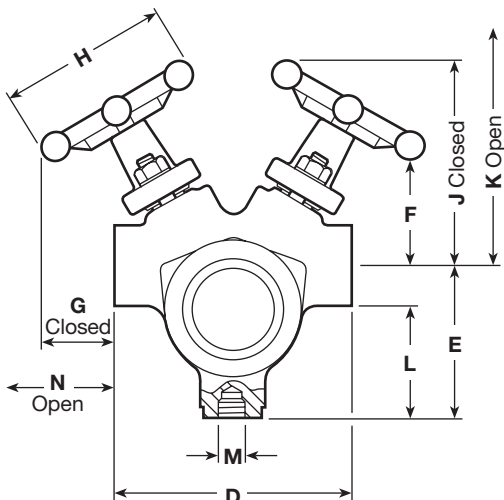

**How to order**

**Example:** 1 off Spirax Sarco MSC08 steam distribution and condensate collection manifold in A105N forged carbon steel body with integral piston valves having 8 x DN20 socket weld connections to ANSI B 16.11 Class 3000. Complete with EN 10204 3.1 certification as standard for the body and bonnet.

**Spare parts**

The spare parts available are detailed below. For ease of replacement an extractor tool is available for removing the sealing rings.

**Available spares**

Sealing ring set	<b>2, 3</b>
Valve internals set	<b>2, 3, 4, 5, 6, 8, 13</b>
Extractor tool	

**How to order spares**



Always order spares by using the description given in the column headed 'Available spares' and state the type and size of manifold.

**Example:** 1 off Sealing ring set for an integral piston valve on a carbon steel manifold MSC04 DN15 socket weld.

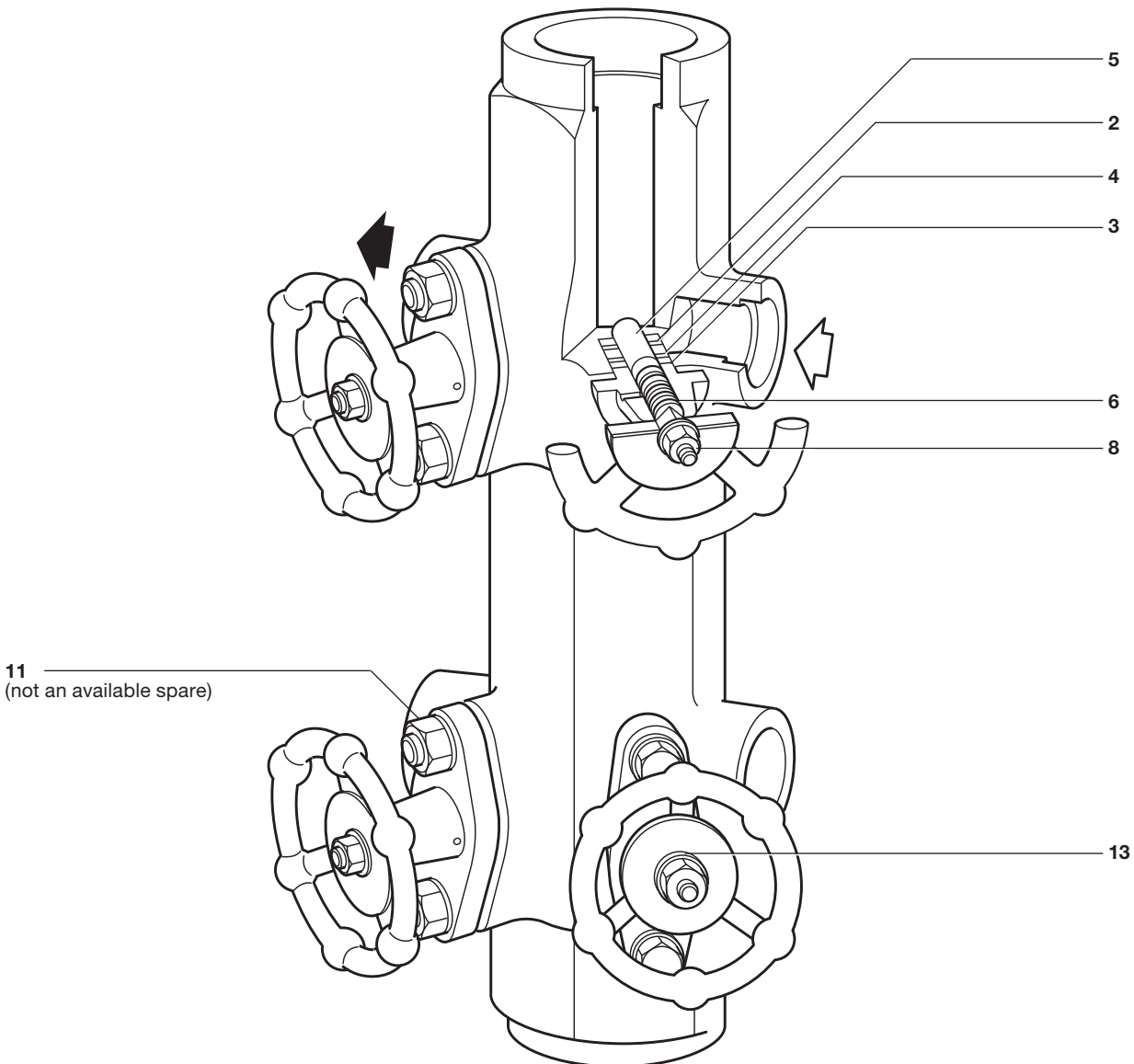
**MSC04 shown having socket weld connections**



**Recommended tightening torques**

Item	Part	 or mm		N m
8	Handwheel nut	10 A/F	M6	0.1
11	Bonnet nuts	14 A/F		5.0