

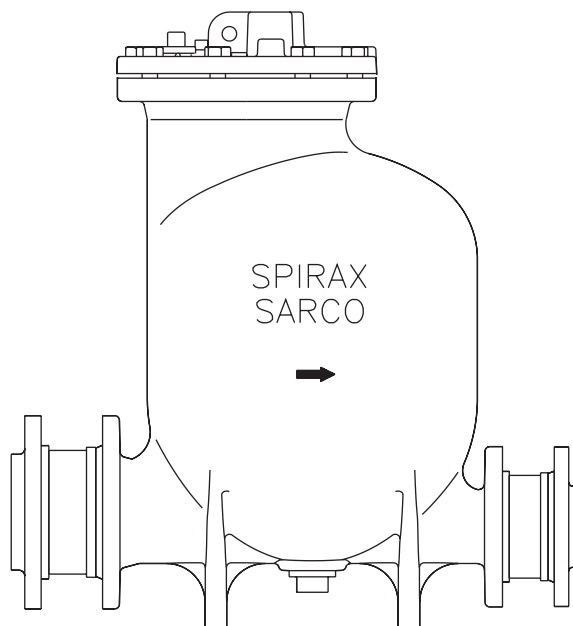

MFP14, MFP14S and MFP14SS Automatic Pumps





Description

The Spirax Sarco MFP14 automatic pump is a displacement receiver operated by steam or compressed air. It is generally used to lift liquids such as condensate to a higher level. Subject to the conditions being suitable, the pump can also be used to directly drain closed vessels under vacuum or pressure. In conjunction with a float steam trap the pump can be used to effectively drain temperature controlled heat exchangers under all operating conditions.

Available types

The MFP14 is available with the following body materials:	SG iron	MFP14
	Cast steel	MFP14S
	Stainless steel	MFP14SS

Standards

This product fully complies with the requirements of the EU Pressure Equipment Directive/UK Pressure Equipment (Safety) Regulations, ATEX Directive 2014/34/EU and carries the  and  marks when so required.

Certification

Note: Applicable to EU countries and UK only

This product is available with certification to EN 10204 3.1.

Designed in accordance with AD-Merkblätter and ASME VIII Div 1.

All certification/inspection requirements must be stated at the time of order placement.

Sizes and pipe connections

MFP14 SG iron

- 1", 1½", 2" and 3" x 2" screwed BSP (BS 21 parallel).
- DN25, DN40, DN50 and DN80 x DN50 flanged
- EN 1092 PN16, ANSI B 16.5 Class 150 and JIS/KS B 2238 10.

MFP14S Cast steel

- DN50 flanged EN 1092 PN16, ANSI B 16.5
- Class 150 and JIS/KS B2238 10.
- 2" screwed BSP/NPT connections are available to special order.

MFP14SS Stainless steel

- DN50 flanged EN 1092 PN16, ANSI B 16.5
- Class 150 JIS/KS B 2238 10.
- 2" screwed BSP/NPT connections are available to special order.

Optional extras

Electronic pump monitors

A plugged boss is provided on the pump cover, screwed ½" BSP for connecting an electronic pump monitor (For full details see TI-P136-24):

- **EPM1**
A simple stand-alone unit with an 8 digit LCD display, powered by an integral 1.5 V lithium battery.
- **EPM2**
A version suitable for coupling to a remote counter/building energy management system (BEMS).

Insulation jacket

An insulation jacket tailor made for each size of MFP14 is available for energy savings and health and safety. See TI-P136-07.

Materials

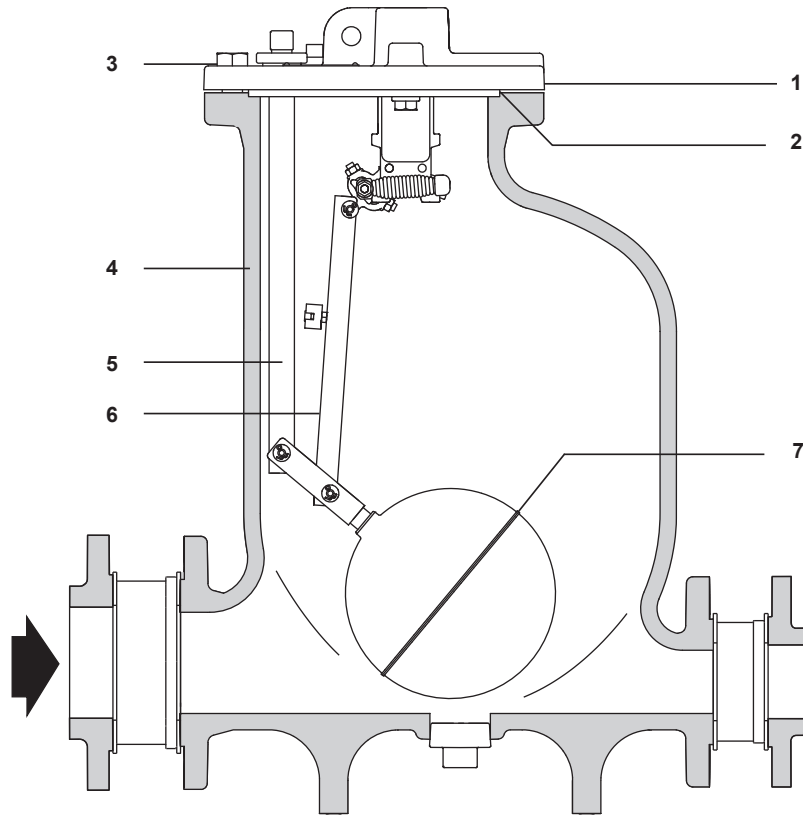

No.	Part	Material	
1	Cover	MFP14	SG iron (EN JS 1025) EN-GJS-400-18-LT
		MFP14S	Cast steel DIN GSC 25N ASTM A216 WCB
		MFP14SS	Stainless steel BS EN 10213-4 144091 ASTM A351 CF3M
2	Cover gasket	Synthetic fibre	
3	Cover screws	Stainless steel	ISO 3506 Gr. A2-70
4	Body	MFP14	SG iron (EN JS 1025) EN-GJS-400-18-LT
		MFP14S	Cast steel DIN GSC 25N ASTM A216 WCB
		MFP14SS	Stainless steel BS EN 10213-4 144091 ASTM A351 CF3M
5	Pillar	Stainless steel	BS 970, 431 S29
6	Connector rod	Stainless steel	BS 1449, 304 S11
7	Float and lever	Stainless steel	AISI 304

Materials continued on the next page

Materials

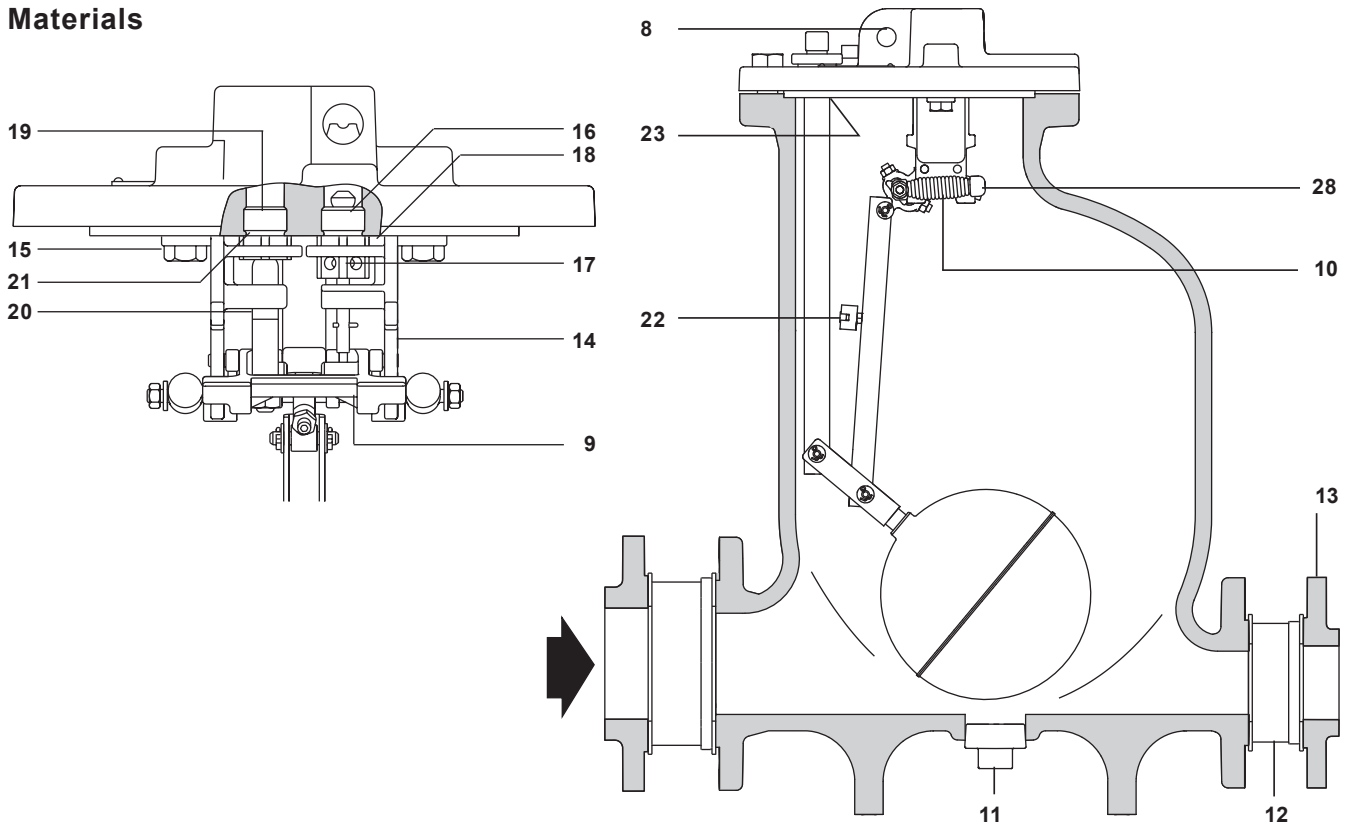

No.	Part	Material	
	MFP14	SG iron	(EN JS 1025) EN-GJS-400-18-LT
8	Eyebolt (integral)	MFP14S	Cast steel DIN GSC 25N ASTM A216 WCB
		MFP14SS	Stainless steel BS EN 10213-4 1998 - 144091 ASTM A351 CF3M
9	Mechanism lever	Stainless steel	BS 3146 pt.2 ANC 2
10	Spring	DN50 and DN80	Inconel 718 ASTM 5962ASTM B367
		DN40	Stainless steel BS 2056 302 526 GRADE 2
11	Pressure plug	Steel	DIN 267 Part III Class 5.8
12	Check valves	Stainless steel	
13	Screwed boss flanges	Steel	
14	Mechanism bracket	Stainless steel	BS 3146 pt. 2 ANC 4B
15	Bracket screws	Stainless steel	BS 6105 Gr. A2-70
16	Inlet valve seat	Stainless steel	BS 970, 431 S29
17	Inlet valve stem	Stainless steel	ASTM A276 440B
18	Inlet valve seat gasket	Stainless steel	BS 1449 409 S19
19	Exhaust valve seat	Stainless steel	BS 970 431 S29
20	Exhaust valve	Stainless steel	BS 3146 pt. 2 ANC 2
21	Exhaust valve seat gasket	Stainless steel	BS 1449 409 S19
22	EPM actuator	ALNICO	
23	'O' ring seal	EPDM	
28	Spring anchor	Stainless steel	BS 970 431 S29

Pressure/temperature limits

MFP14

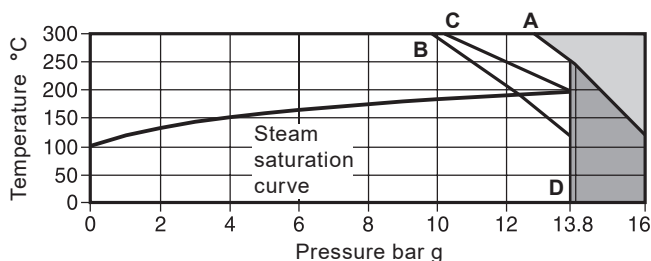

MFP14S

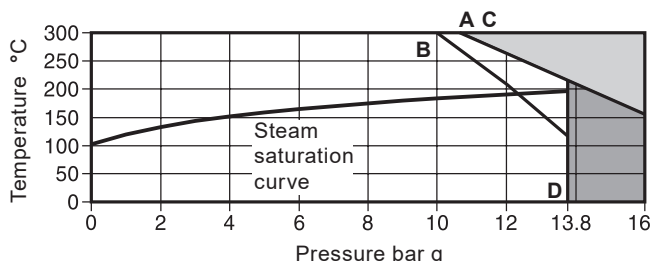

The product **must not** be used in this region.

For use in this region contact Spirax Sarco -
As standard this product should not be used in this region or beyond its operating range.

A - D Flanged PN16

B - D Flanged JIS/KS 10

C - D Flanged ANSI 150

Body design conditions		PN16	
		MFP14	MFP14S
Maximum motive inlet pressure (steam air or gas)		13.8 bar g	13.8 bar g
PMA	Maximum allowable pressure	16 bar g @ 120 °C	16 bar g @ 120 °C
TMA	Maximum allowable temperature	300 °C @ 12.8 bar g	300 °C @ 10.8 bar g
Minimum allowable temperature. For lower temperatures consult Spirax Sarco		0 °C	
PMO	Maximum operating pressure for saturated steam service	13.8 bar g @ 198 °C	13.8 bar g @ 198 °C
TMO	Maximum operating temperature for saturated steam service	198 °C @ 13.8 bar g	198 °C @ 13.8 bar g
Minimum operating temperature. For lower temperatures consult Spirax Sarco		0 °C	

Total lift or backpressure (static head plus pressure in the return system) which must be below the motive fluid inlet pressure to allow capacity to be achieved:-

Height (H) in metres x 0.0981 plus pressure (bar g) in return line, plus downstream piping friction pressure drop in bar calculated at a flowrate of the lesser of six times the actual condensate rate or 30 000 litres/h.

Recommended filling head above the pump 0.3 m

Minimum filling head required 0.15 m (reduced capacity)

Standard pump operates with liquids of specific gravity: 1 down to 0.8

	DN80 x 50	DN50	DN40 and DN25
Pump discharge per cycle	19.3 litres	12.8 litres	7 litres
Steam consumption	20 kg/h maximum	20 kg/h maximum	16 kg/h maximum
Air consumption (Free air)	5.6 dm ³ /s maximum	5.6 dm ³ /s maximum	4.4 dm ³ /s maximum
Temperature limits (Ambient)	-10 °C to 200 °C	-10 °C to 200 °C	-10 °C to 200 °C

The MFP14SS Pressure/temperature limits are shown on the next page

Pressure/temperature limits

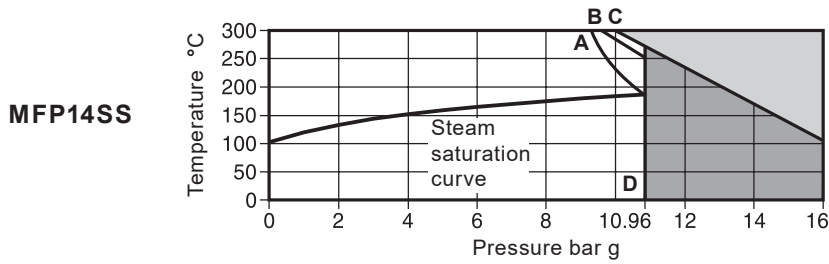

The product **must not** be used in this region.

For use in this region contact Spirax Sarco -
As standard this product should not be used in this region or beyond its operating range.

A - D Flanged PN16

B - D Flanged JIS/KS 10

C - D Flanged ANSI 150

Body design conditions

		MFP14SS
Maximum motive inlet pressure (steam air or gas)		10.96 bar g
PMA	Maximum allowable pressure	16 bar g @ 93 °C
TMA	Maximum allowable temperature	300 °C @ 9.3 bar g
Minimum allowable temperature. For lower temperatures consult Spirax Sarco		
PMO	Maximum operating pressure for saturated steam service	10.96 bar g @ 188 °C
TMO	Maximum operating temperature for saturated steam service	188 °C @ 10.96 bar g
Minimum operating temperature. For lower temperatures consult Spirax Sarco		

Total lift or backpressure (static head plus pressure in the return system) which must be below the motive fluid inlet pressure to allow capacity to be achieved:-

Height (H) in metres x 0.0981 plus pressure (bar g) in return line, plus downstream piping friction pressure drop in bar calculated at a flowrate of the lesser of six times the actual condensate rate or 30 000 litres/h.

Recommended filling head above the pump	0.3 m
Minimum filling head required	0.15 m (reduced capacity)
Standard pump operates with liquids of specific gravity:	1 down to 0.8

	DN80 x 50	DN50	DN40 and DN25
Pump discharge per cycle	19.3 litres	12.8 litres	7 litres
Steam consumption	20 kg/h maximum	20 kg/h maximum	16 kg/h maximum
Air consumption (Free air)	5.6 dm ³ /s maximum	5.6 dm ³ /s maximum	4.4 dm ³ /s maximum
Temperature limits (Ambient)	-10 °C to 200 °C	-10 °C to 200 °C	-10 °C to 200 °C

Dimensions/weights (approximate) in mm and kg

Size	A		B	C	D	E	F	G	H	J	K	L	Weight	
	JIS/KS PN	ANSI											Pump only	Including check valves and flanges
DN25	410	-	305	507.0	-	68	68	480	13	18	165	Ø 280	51	58
DN40	440	-	305	527.0	-	81	81	480	13	18	165	Ø 280	54	63
DN50	557	625	420	637.5	-	104	104	580	33	18	245	Ø 321	72	82
DN80 x DN50	573	645	420	637.5	430	119	104	580	33	18	245	342	88	98

* **Note:** Dimension **D** only applies to the DN80 x DN50 pump which has an oval body. The DN25, DN40 and DN50 are round bodied therefore dimension **L** is sufficient.

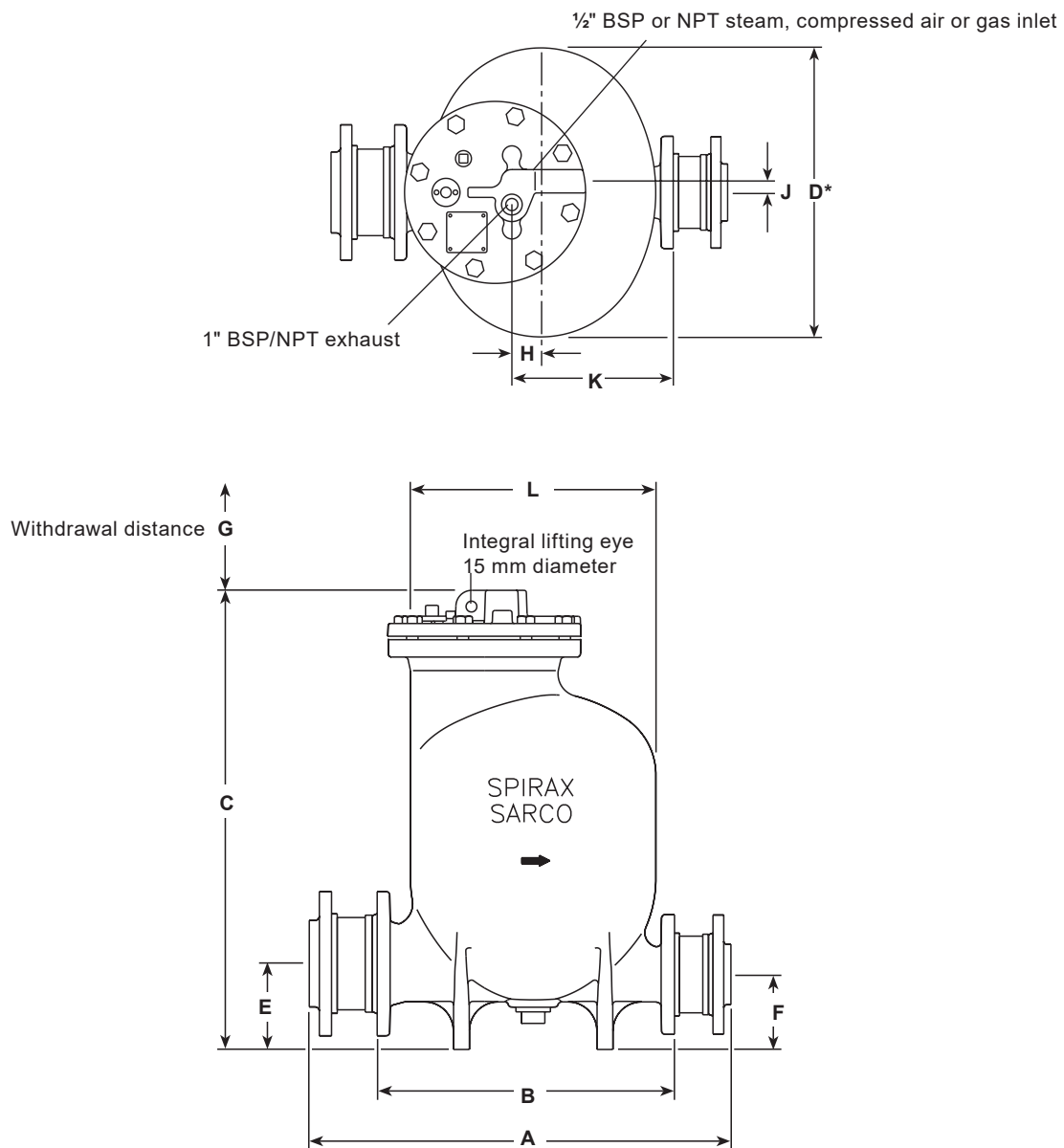

How to size and select

Considering the inlet pressure, backpressure and filling head conditions, select the pump size which meets the capacity requirements of the application.

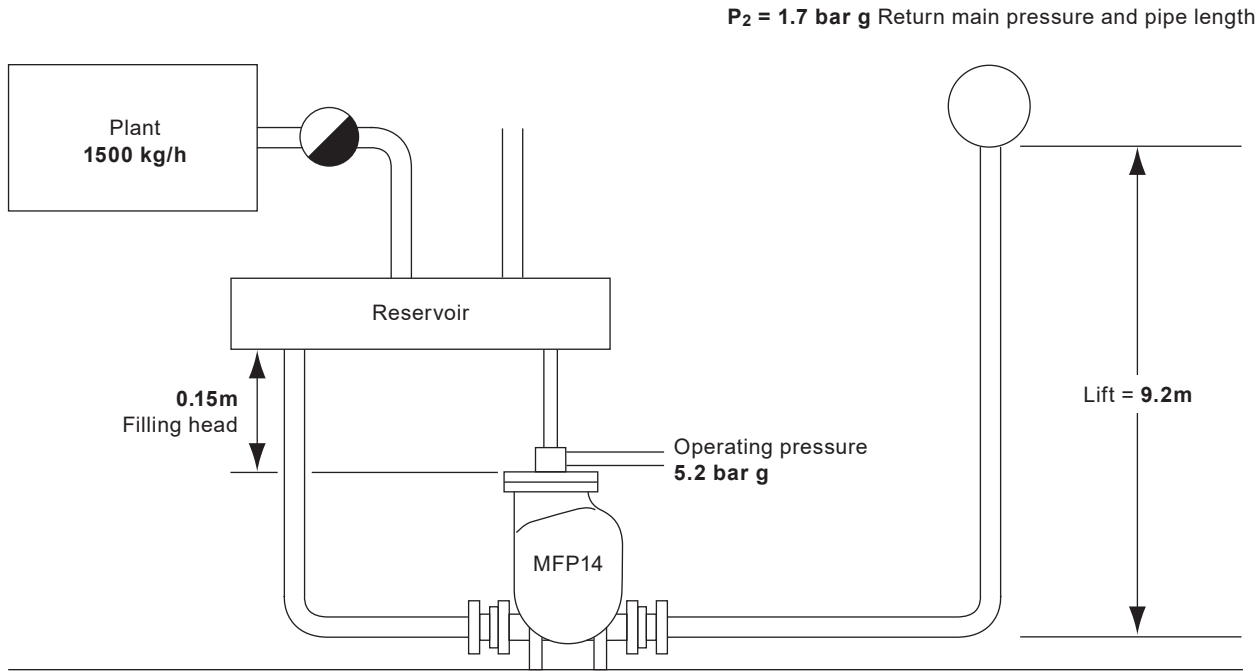

The known data

Condensate load	1500 kg/h
Steam pressure available for operating pump	5.2 bar g
Vertical lift from pump to the return piping	9.2 m
Pressure in the return piping (piping friction negligible)	1.7 bar g
Filling head on the pump available	0.15 m

Note: It is strongly recommended that the maximum motive/backpressure differential is between 2-4 bar g.

Selection example

Firstly calculate the total effective lift against which condensate must be pumped.

Total effective lift is calculated by adding **vertical lift from the pump to return piping (9.2 m)** to the **pressure in the return piping (1.7 bar g)**. To convert pressure in the return pipe into pressure head, divide it by the conversion factor of 0.0981:-

$$P_2 = 1.7 \text{ bar g} \div 0.0981 = 17.3 \text{ m Pressure head (lift)}$$

The total effective lift then becomes calculable :-

$$9.2 \text{ m} + 17.3 \text{ m}$$

The total effective lift is 26.5 m

Now that the total effective lift has been calculated, a pump can be selected by plotting the known data onto the graphs on page 6.

1. Plot a horizontal line from 5.2 bar g (Motive pressure).
2. Plot a line indicating 26.5 m lift.
3. From the point where the motive pressure line crosses the m lift line, drop a vertical line to the X axis.
4. Read the corresponding capacity (2400 kg/h).

Note: As the filling head is different to 0.3 m, then the capacity calculated above must be corrected by the appropriate factor selected from the table opposite.

How to use the sizing chart

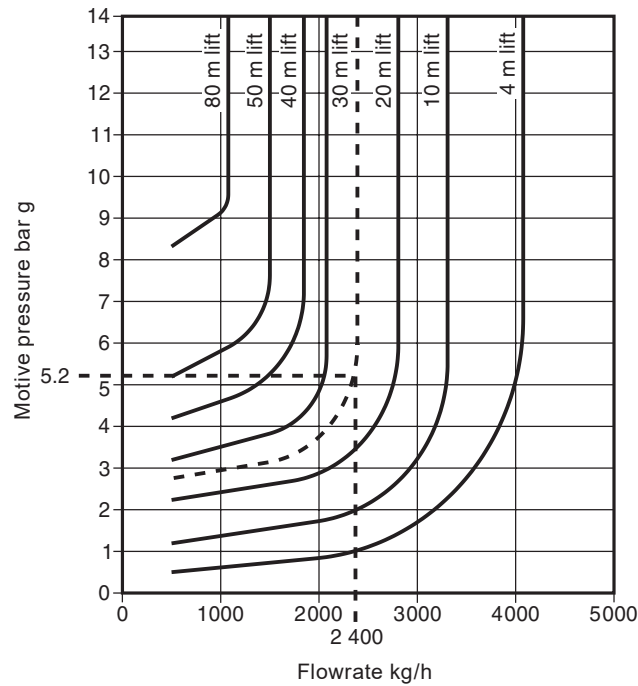

Example: DN50 pump capacities

Capacity multiplying factors for other filling heads

Filling head metres (m)	Capacity multiplying factors			
	DN25	DN40	DN50	DN80 x DN50
0.15	0.90	0.75	0.75	0.80
0.30	1.00	1.00	1.00	1.00
0.60	1.15	1.10	1.20	1.05
0.90	1.35	1.25	1.30	1.15

For motive fluids other than steam, see the table below.

Final pump selection

The size of pump selected in this case would be **DN50**.

This has the capability to pump:-

$$0.75 \times 2400 \text{ kg/h} = 1800 \text{ kg/h}$$

easily coping with a condensate load of 1500 kg/h.

Note: Steam is the recommended motive fluid for steam systems. If the motive fluid is not steam, then the capacity above must be multiplied by the appropriate factor in the table below.

Capacity multiplying factors for motive gas supplies (other than steam)

Pump size	% Backpressure Vs Motive pressure (BP/MP)								
	10%	20%	30%	40%	50%	60%	70%	80%	90%
DN25	1.20	1.25	1.30	1.35	1.40	1.43	1.46	1.50	1.53
DN40	1.20	1.25	1.30	1.35	1.40	1.43	1.46	1.50	1.53
DN50	1.02	1.05	1.08	1.10	1.15	1.20	1.27	1.33	1.40
DN80 x DN50	1.02	1.05	1.08	1.10	1.15	1.20	1.27	1.33	1.40

The capacity charts are based on a filling head of 0.3 m. The lift lines represent the net effective lift (i.e. lift plus frictional resistance).

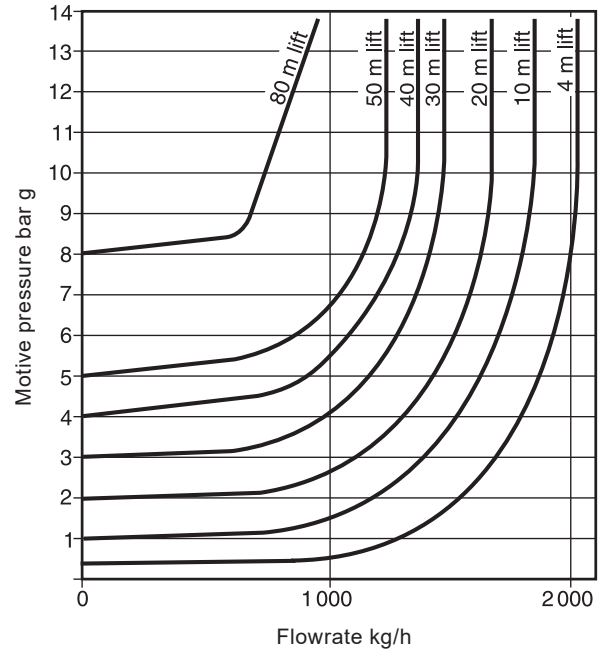
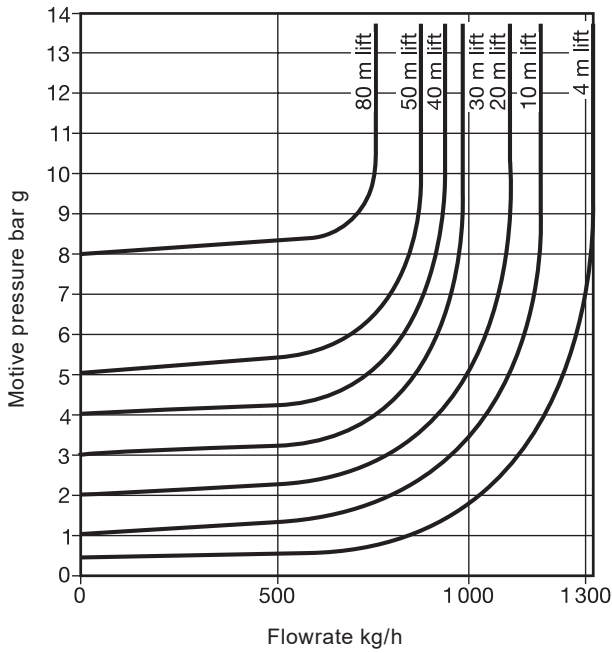

DN25 pump capacities

DN40 pump capacities

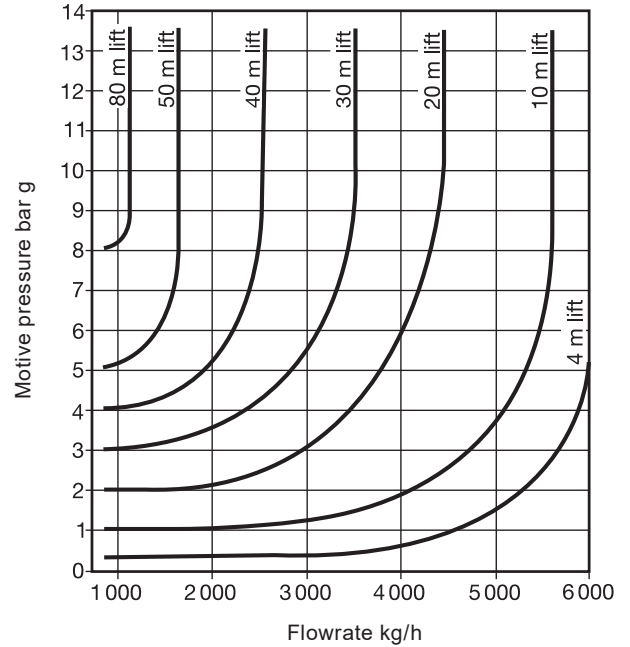
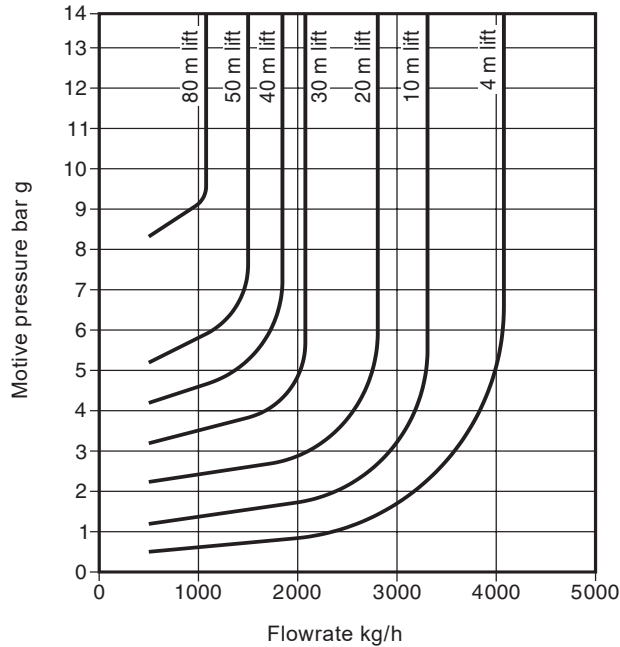

DN50 pump capacities

DN80 x DN50 pump capacities

Note: If you are in any doubt about the size of the pump required or if the conditions are unusual we will be glad to advise you if you give us the answers to the following questions:-

1. Nature of liquid to be pumped.
2. Temperature of liquid to be pumped.
3. Quantity to be pumped (kg/h or litres/h).
4. Initial lift horizontal distance and net effective lift (i.e. initial lift less subsequent fall in discharge line).
5. Operating medium (steam, compressed air or gas).
6. Operating pressure available.
7. The pump is generally used to drain water from a vented receiver but under certain circumstances can drain a unit from under steam pressure or vacuum - state which.

Note: To achieve rated capacity, the pump must be installed with check valves as supplied by Spirax Sarco. Use of a substitute check valve may affect the performance of the pump.

Safety information, installation and maintenance

For full details see the Installation and Maintenance Instructions (IM-P136-03) supplied with the product.

Installation note:

- For best operation any flash steam must be vented or condensed ahead of the pump inlet.
- Steam is the recommended motive fluid for steam systems.

How to specify

Automatic pumps shall be Spirax Sarco type MFP14 with SG iron bodies and flanged/screwed connections. They shall have stainless steel valve and float assemblies, and a stainless steel disc check valve on the condensate inlet and outlet connections. They shall have screwed steam/compressed air inlet and exhaust connections.

How to order

Example: 1 off Spirax Sarco DN50 MFP14 automatic pump having flanged EN 1092 PN16 connections with BSP motive fluid connections, complete with check valves and 2" BSP screwed boss flanges.

Spare parts

The spare parts available are detailed below. No other parts are available as spares.

Available spares

Cover gasket	2
Float	7
Inlet/outlet check valve (each)	12
Cover and internal mechanism assembly	1, 2, 7 (complete)
Valve set (inlet and exhaust valves and seats)	16, 17, 18, 19, 20, 21
Spring shaft kit (two spring assemblies including anchors and two shafts plus nuts and washers for rear shaft)	10

How to order spares

Always order spares by using the description given in the column headed 'Available spares' and state the size and type of pump.

Example: 1 off Cover gasket for a Spirax Sarco DN50 MFP14 automatic pump.

